

SN54AHC123A, SN74AHC123A DUAL RETRIGGERABLE MONOSTABLE MULTIVIBRATORS

SCLS352D – JULY 1997 – REVISED DECEMBER 1999

- **EPIC™ (Enhanced-Performance Implanted CMOS) Process**
- **Operating Range 2-V to 5.5-V V_{CC}**
- **Schmitt-Trigger Circuitry On \bar{A} , B, and \bar{CLR} Inputs for Slow Input Transition Rates**
- **Edge Triggered From Active-High or Active-Low Gated Logic Inputs**
- **Retriggerable for Very Long Output Pulses**
- **Overriding Clear Terminates Output Pulse**
- **Glitch-Free Power-Up Reset On Outputs**
- **Latch-Up Performance Exceeds 100 mA Per JESD 78, Class II**
- **ESD Protection Exceeds JESD 22**
 - 2000-V Human-Body Model (A114-A)
 - 200-V Machine Model (A115-A)
 - 1000-V Charged-Device Model (C101)
- **Package Options Include Plastic Small-Outline (D), Shrink Small-Outline (DB), Thin Very Small-Outline (DGV), Thin Shrink Small-Outline (PW), and Ceramic Flat (W) Packages, Ceramic Chip Carriers (FK), and Standard Plastic (N) and Ceramic (J) DIPs**

description

The 'AHC123A devices are dual retriggerable monostable multivibrators designed for 2-V to 5.5-V V_{CC} operation.

These edge-triggered multivibrators feature output pulse-duration control by three methods. In the first method, the \bar{A} input is low, and the B input goes high. In the second method, the B input is high, and the \bar{A} input goes low. In the third method, the \bar{A} input is low, the B input is high, and the clear (\bar{CLR}) input goes high.

The output pulse duration is programmed by selecting external resistance and capacitance values. The external timing capacitor must be connected between C_{ext} and R_{ext}/C_{ext} (positive) and an external resistor connected between R_{ext}/C_{ext} and V_{CC} . To obtain variable pulse durations, connect an external variable resistance between R_{ext}/C_{ext} and V_{CC} . The output pulse duration also can be reduced by taking \bar{CLR} low.

Pulse triggering occurs at a particular voltage level and is not directly related to the transition time of the input pulse. The \bar{A} , B, and \bar{CLR} inputs have Schmitt triggers with sufficient hysteresis to handle slow input transition rates with jitter-free triggering at the outputs.

Once triggered, the basic pulse duration can be extended by retriggering the gated low-level-active (\bar{A}) or high-level-active (B) input. Pulse duration can be reduced by taking \bar{CLR} low. \bar{CLR} input can be used to override \bar{A} or B inputs. The input/output timing diagram illustrates pulse control by retriggering the inputs and early clearing.

SN54AHC123A . . . J OR W PACKAGE
SN74AHC123A . . . D, DB, DGV, N, OR PW PACKAGE
(TOP VIEW)

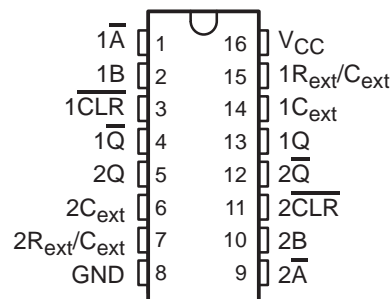

SN54AHC123A . . . FK PACKAGE
(TOP VIEW)

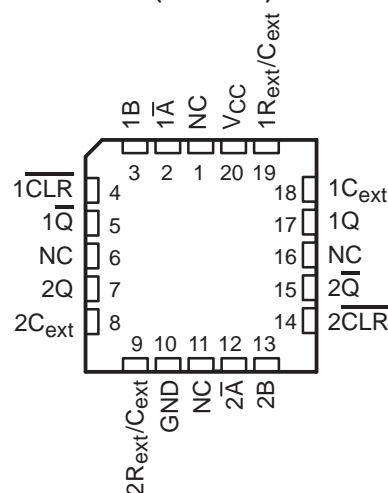

NC – No internal connection



Please be aware that an important notice concerning availability, standard warranty, and use in critical applications of Texas Instruments semiconductor products and disclaimers thereto appears at the end of this data sheet.

EPIC is a trademark of Texas Instruments Incorporated.

PRODUCTION DATA information is current as of publication date. Products conform to specifications per the terms of Texas Instruments standard warranty. Production processing does not necessarily include testing of all parameters.

**TEXAS
INSTRUMENTS**

POST OFFICE BOX 655303 • DALLAS, TEXAS 75265

Copyright © 1999, Texas Instruments Incorporated
On products compliant to MIL-PRF-38535, all parameters are tested unless otherwise noted. On all other products, production processing does not necessarily include testing of all parameters.

SN54AHC123A, SN74AHC123A DUAL RETRIGGERABLE MONOSTABLE MULTIVIBRATORS

SCLS352D – JULY 1997 – REVISED DECEMBER 1999

description (continued)

The variance in output pulse duration from device to device typically is less than $\pm 0.5\%$ for given external timing components. An example of this distribution for the 'AHC123A is shown in Figure 10. Variations in output pulse duration versus supply voltage and temperature are shown in Figure 6.

During power up, Q outputs are in the high state, and \bar{Q} outputs are in the low state. The outputs are glitch free without applying a reset pulse.

The SN54AHC123A is characterized for operation over the full military temperature range of -55°C to 125°C . The SN74AHC123A is characterized for operation from -40°C to 85°C .

For additional application information on multivibrators, see the application report *Designing With The SN74AHC123A and SN74AHCT123A*, literature number SCLA014.

FUNCTION TABLE
(each multivibrator)

| INPUTS | | | OUTPUTS | |
|-------------------------|--------------|------------|-------------|-------------|
| $\overline{\text{CLR}}$ | \bar{A} | B | Q | \bar{Q} |
| L | X | X | L | H |
| X | H | X | L \dagger | H \dagger |
| X | X | L | L \dagger | H \dagger |
| H | L | \uparrow | \square | \square |
| H | \downarrow | H | \square | \square |
| \uparrow | L | H | \square | \square |

\dagger These outputs are based on the assumption that the indicated steady-state conditions at the A and B inputs have been set up long enough to complete any pulse started before the setup.

logic symbol \ddagger

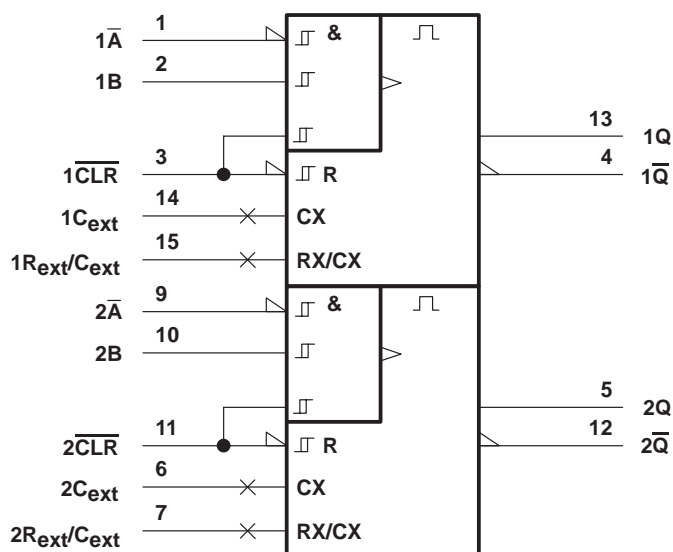

\ddagger This symbol is in accordance with ANSI/IEEE Std 91-1984 and IEC Publication 617-12. Pin numbers shown are for the D, DB, DGV, J, N, PW, and W packages.

SN54AHC123A, SN74AHC123A DUAL RETRIGGERABLE MONOSTABLE MULTIVIBRATORS

SCLS352D – JULY 1997 – REVISED DECEMBER 1999

logic diagram, each multivibrator (positive logic)

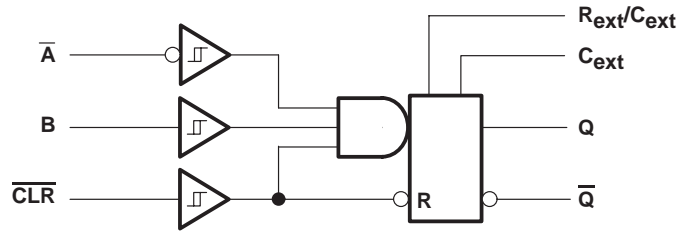

input/output timing diagram

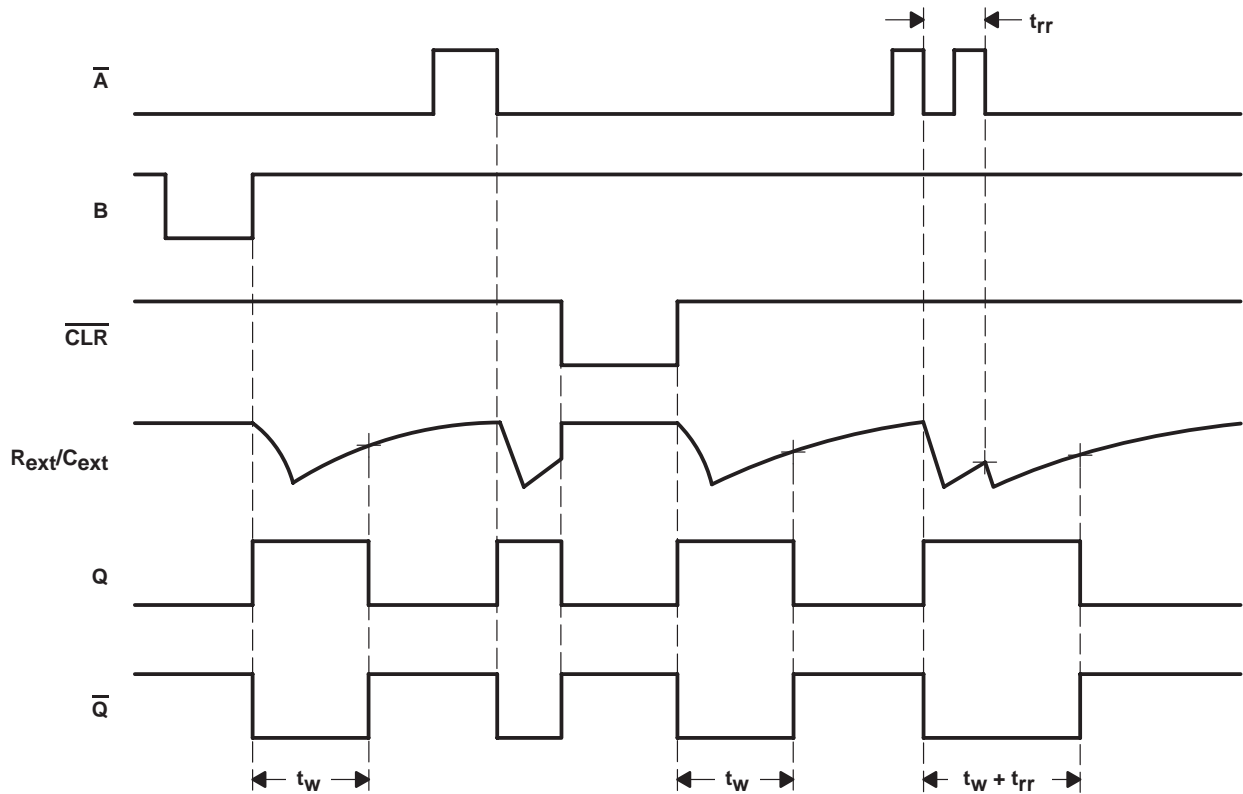

SN54AHC123A, SN74AHC123A DUAL RETRIGGERABLE MONOSTABLE MULTIVIBRATORS

SCLS352D – JULY 1997 – REVISED DECEMBER 1999

absolute maximum ratings over operating free-air temperature (unless otherwise noted)†

| | |
|--|----------------------------|
| Supply voltage, V_{CC} (see Note 1) | –0.5 V to 7 V |
| Input voltage, V_I (see Note 2) | –0.5 V to 7 V |
| Output voltage range in high or low state, V_O (see Note 1) | –0.5 V to $V_{CC} + 0.5$ V |
| Output voltage range in power-off state, V_O (see Note 1) | –0.5 V to 7 V |
| Input clamp current, I_{IK} ($V_I < 0$) | –20 mA |
| Output clamp current, I_{OK} ($V_O < 0$ or $V_O > V_{CC}$) | ±20 mA |
| Continuous output current, I_O ($V_O = 0$ to V_{CC}) | ±25 mA |
| Continuous current through V_{CC} or GND | ±50 mA |
| Package thermal impedance, θ_{JA} (see Note 3): | |
| D package | 73°C/W |
| DB package | 82°C/W |
| DGV package | 120°C/W |
| N package | 67°C/W |
| PW package | 108°C/W |
| Storage temperature range, T_{stg} | –65°C to 150°C |

† Stresses beyond those listed under “absolute maximum ratings” may cause permanent damage to the device. These are stress ratings only, and functional operation of the device at these or any other conditions beyond those indicated under “recommended operating conditions” is not implied. Exposure to absolute-maximum-rated conditions for extended periods may affect device reliability.

- NOTES: 1. Voltage values are with respect to the network ground terminal.
 2. The input and output voltage ratings may be exceeded if the input and output current ratings are observed.
 3. The package thermal impedance is calculated in accordance with JESD 51.

recommended operating conditions (see Note 4)

| | | SN54AHC123A | | SN74AHC123A | | UNIT |
|--------------------------|--------------------------------|--------------------------|----------|-------------|----------|----------|
| | | MIN | MAX | MIN | MAX | |
| V_{CC} | Supply voltage | 2 | 5.5 | 2 | 5.5 | V |
| V_{IH} | High-level input voltage | $V_{CC} = 2$ V | | 1.5 | | V |
| | | $V_{CC} = 3$ V | | 2.1 | | |
| | | $V_{CC} = 5.5$ V | | 3.85 | | |
| V_{IL} | Low-level input voltage | $V_{CC} = 2$ V | | 0.5 | | V |
| | | $V_{CC} = 3$ V | | 0.9 | | |
| | | $V_{CC} = 5.5$ V | | 1.65 | | |
| V_I | Input voltage | 0 | 5.5 | 0 | 5.5 | V |
| V_O | Output voltage | 0 | V_{CC} | 0 | V_{CC} | V |
| I_{OH} | High-level output current | $V_{CC} = 2$ V | | –50 | | μ A |
| | | $V_{CC} = 3.3$ V ± 0.3 V | | –4 | | mA |
| | | $V_{CC} = 5$ V ± 0.5 V | | –8 | | mA |
| I_{OL} | Low-level output current | $V_{CC} = 2$ V | | 50 | | μ A |
| | | $V_{CC} = 3.3$ V ± 0.3 V | | 4 | | mA |
| | | $V_{CC} = 5$ V ± 0.5 V | | 8 | | mA |
| R_{ext} | External timing resistance | $V_{CC} = 2$ V | | 5k | | Ω |
| | | $V_{CC} > 3$ V | | 1k | | |
| $\Delta t/\Delta V_{CC}$ | Power-up ramp rate | 1 | | 1 | | ms/V |
| T_A | Operating free-air temperature | –55 | 125 | –40 | 85 | °C |

NOTE 4: All unused inputs of the device must be held at V_{CC} or GND to ensure proper device operation. Refer to the TI application report, *Implications of Slow or Floating CMOS Inputs*, literature number SCBA004.



SN54AHC123A, SN74AHC123A DUAL RETRIGGERABLE MONOSTABLE MULTIVIBRATORS

SCLS352D – JULY 1997 – REVISED DECEMBER 1999

electrical characteristics over recommended operating free-air temperature range (unless otherwise noted)

| PARAMETER | TEST CONDITIONS | V _{CC} | T _A = 25°C | | | SN54AHC123A | | SN74AHC123A | | UNIT | |
|-----------------|--------------------------------------|---|-----------------------|-----|------|-------------|-----|-------------|-----|------|----|
| | | | MIN | TYP | MAX | MIN | MAX | MIN | MAX | | |
| V _{OH} | I _{OH} = -50 μA | 2 V | 1.9 | 2 | | 1.9 | | 1.9 | V | | |
| | | 3 V | 2.9 | 3 | | 2.9 | | 2.9 | | | |
| | | 4.5 V | 4.4 | 4.5 | | 4.4 | | 4.4 | | | |
| | I _{OH} = -4 mA | 3 V | 2.58 | | | 2.48 | | 2.48 | | | |
| | I _{OH} = -8 mA | 4.5 V | 3.94 | | | 3.8 | | 3.8 | | | |
| V _{OL} | I _{OL} = 50 μA | 2 V | | | 0.1 | | 0.1 | | V | | |
| | | 3 V | | | 0.1 | | 0.1 | | | | |
| | | 4.5 V | | | 0.1 | | 0.1 | | | | |
| | I _{OL} = 4 mA | 3 V | | | 0.36 | | 0.5 | | | | |
| | I _{OL} = 8 mA | 4.5 V | | | 0.36 | | 0.5 | | | | |
| I _I | R _{ext} /C _{ext} † | V _I = V _{CC} or GND | 5.5 V | | | ±0.25 | | ±2.5 | | μA | |
| | A̅, B, and CLR̅ | V _I = V _{CC} or GND | 0 V | | | ±0.1 | | ±1 | | | |
| | | | 5.5 V | | | ±0.1 | | ±1 | | | |
| I _{CC} | Quiescent | V _I = V _{CC} or GND, I _O = 0 | 5.5 V | | | 4 | | 40 | | μA | |
| I _{CC} | Active state (per circuit) | V _I = V _{CC} or GND, R _{ext} /C _{ext} = 0.5 V _{CC} | 3 V | | 160 | 250 | | 280 | | 280 | μA |
| | | | 4.5 V | | 280 | 500 | | 650 | | 650 | |
| | | | 5.5 V | | 360 | 750 | | 975 | | 975 | |
| C _i | | V _I = V _{CC} or GND | 5 V | | 1.9 | 10 | | | | 10 | pF |

† This test is performed with the terminal in the off-state condition.

timing requirements over recommended operating free-air temperature range, V_{CC} = 3.3 V ± 0.3 V (unless otherwise noted) (see Figure 1)

| | TEST CONDITIONS | T _A = 25°C | | | SN54AHC123A | | SN74AHC123A | | UNIT |
|--------------------------------------|---|-----------------------|-----|-----|-------------|-----|-------------|-----|------|
| | | MIN | TYP | MAX | MIN | MAX | MIN | MAX | |
| t _w Pulse duration | CLR̅ | | 5 | | | 5 | | 5 | ns |
| | A̅ or B trigger | | 5 | | | 5 | | 5 | |
| t _{rr} Pulse retrigger time | R _{ext} = 1 kΩ, C _{ext} = 100 pF | ‡ | 76 | | | ‡ | | ‡ | ns |
| | R _{ext} = 1 kΩ, C _{ext} = 0.01 μF | ‡ | 1.8 | | | ‡ | | ‡ | μs |

‡ See retriggering data in the application information section.

timing requirements over recommended operating free-air temperature range, V_{CC} = 5 V ± 0.5 V (unless otherwise noted) (see Figure 1)

| | TEST CONDITIONS | T _A = 25°C | | | SN54AHC123A | | SN74AHC123A | | UNIT |
|--------------------------------------|---|-----------------------|-----|-----|-------------|-----|-------------|-----|------|
| | | MIN | TYP | MAX | MIN | MAX | MIN | MAX | |
| t _w Pulse duration | CLR̅ | | 5 | | | 5 | | 5 | ns |
| | A̅ or B trigger | | 5 | | | 5 | | 5 | |
| t _{rr} Pulse retrigger time | R _{ext} = 1 kΩ, C _{ext} = 100 pF | ‡ | 59 | | | ‡ | | ‡ | ns |
| | R _{ext} = 1 kΩ, C _{ext} = 0.01 μF | ‡ | 1.5 | | | ‡ | | ‡ | μs |

‡ See retriggering data in the application information section.



SN54AHC123A, SN74AHC123A DUAL RETRIGGERABLE MONOSTABLE MULTIVIBRATORS

SCLS352D – JULY 1997 – REVISED DECEMBER 1999

switching characteristics over recommended operating free-air temperature range,
 $V_{CC} = 3.3\text{ V} \pm 0.3\text{ V}$ (unless otherwise noted) (see Figure 1)

| PARAMETER | FROM (INPUT) | TO (OUTPUT) | TEST CONDITIONS | $T_A = 25^\circ\text{C}$ | | | SN54AHC123A | | SN74AHC123A | | UNIT |
|-----------------------|---------------------------------|----------------|--|--------------------------|-------|-----|-------------|-------|-------------|------|---------------|
| | | | | MIN | TYP | MAX | MIN | MAX | MIN | MAX | |
| t_{PLH} | \bar{A} or B | Q or \bar{Q} | $C_L = 15\text{ pF}$ | 9.5* | 20.6* | | 1* | 24* | 1 | 24 | ns |
| t_{PHL} | | | | 10.2* | 20.6* | | 1* | 24* | 1 | 24 | |
| t_{PLH} | $\overline{\text{CLR}}$ | Q or \bar{Q} | $C_L = 15\text{ pF}$ | 7.5* | 15.8* | | 1* | 18.5* | 1 | 18.5 | ns |
| t_{PHL} | | | | 9.3* | 15.8* | | 1* | 18.5* | 1 | 18.5 | |
| t_{PLH} | $\overline{\text{CLR}}$ trigger | Q or \bar{Q} | $C_L = 15\text{ pF}$ | 10* | 22.4* | | 1* | 26* | 1 | 26 | ns |
| t_{PHL} | | | | 10.6* | 22.4* | | 1* | 26* | 1 | 26 | |
| t_{PLH} | \bar{A} or B | Q or \bar{Q} | $C_L = 50\text{ pF}$ | 10.5 | 24.1 | | 1 | 27.5 | 1 | 27.5 | ns |
| t_{PHL} | | | | 11.8 | 24.1 | | 1 | 27.5 | 1 | 27.5 | |
| t_{PLH} | $\overline{\text{CLR}}$ | Q or \bar{Q} | $C_L = 50\text{ pF}$ | 8.9 | 19.3 | | 1 | 22 | 1 | 22 | ns |
| t_{PHL} | | | | 10.5 | 19.3 | | 1 | 22 | 1 | 22 | |
| t_{PLH} | $\overline{\text{CLR}}$ trigger | Q or \bar{Q} | $C_L = 50\text{ pF}$ | 11 | 25.9 | | 1 | 29.5 | 1 | 29.5 | ns |
| t_{PHL} | | | | 12.3 | 25.9 | | 1 | 29.5 | 1 | 29.5 | |
| t_w^\dagger | | Q or \bar{Q} | $C_L = 50\text{ pF}$, $C_{ext} = 28\text{ pF}$, $R_{ext} = 2\text{ k}\Omega$ | 182 | 240 | | 300 | | 300 | ns | |
| | | | $C_L = 50\text{ pF}$, $C_{ext} = 0.01\text{ }\mu\text{F}$, $R_{ext} = 10\text{ k}\Omega$ | 90 | 100 | 110 | 90 | 110 | 90 | 110 | μs |
| | | | $C_L = 50\text{ pF}$, $C_{ext} = 0.1\text{ }\mu\text{F}$, $R_{ext} = 10\text{ k}\Omega$ | 0.9 | 1 | 1.1 | 0.9 | 1.1 | 0.9 | 1.1 | ms |
| Δt_w^\ddagger | | | | ± 1 | | | | | | % | |

* On products compliant to MIL-PRF-38535, this parameter is not production tested.

$^\dagger t_w$ = Duration of pulse at Q and \bar{Q} outputs

$^\ddagger \Delta t_w$ = Output pulse-duration variation (Q and \bar{Q}) between circuits in same package



SN54AHC123A, SN74AHC123A DUAL RETRIGGERABLE MONOSTABLE MULTIVIBRATORS

SCLS352D – JULY 1997 – REVISED DECEMBER 1999

**switching characteristics over recommended operating free-air temperature range,
V_{CC} = 5 V ± 0.5 V (unless otherwise noted) (see Figure 1)**

| PARAMETER | FROM (INPUT) | TO (OUTPUT) | TEST CONDITIONS | T _A = 25°C | | | SN54AHC123A | | SN74AHC123A | | UNIT |
|------------------------------|---------------------------------|----------------|--|-----------------------|-------|-----|-------------|-----|-------------|-----|------|
| | | | | MIN | TYP | MAX | MIN | MAX | MIN | MAX | |
| t _{PLH} | \bar{A} or B | Q or \bar{Q} | C _L = 15 pF | 6.5* | 12* | 1* | 14* | 1 | 14 | ns | |
| t _{PHL} | | | | 7.1* | 12* | 1* | 14* | 1 | 14 | | |
| t _{PLH} | $\overline{\text{CLR}}$ | Q or \bar{Q} | C _L = 15 pF | 5.3* | 9.4* | 1* | 11* | 1 | 11 | ns | |
| t _{PHL} | | | | 6.5* | 9.4* | 1* | 11* | 1 | 11 | | |
| t _{PLH} | $\overline{\text{CLR}}$ trigger | Q or \bar{Q} | C _L = 15 pF | 6.9* | 12.9* | 1* | 15* | 1 | 15 | ns | |
| t _{PHL} | | | | 7.4* | 12.9* | 1* | 15* | 1 | 15 | | |
| t _{PLH} | \bar{A} or B | Q or \bar{Q} | C _L = 50 pF | 7.3 | 14 | 1 | 16 | 1 | 16 | ns | |
| t _{PHL} | | | | 8.3 | 14 | 1 | 16 | 1 | 16 | | |
| t _{PLH} | $\overline{\text{CLR}}$ | Q or \bar{Q} | C _L = 50 pF | 6.3 | 11.4 | 1 | 13 | 1 | 13 | ns | |
| t _{PHL} | | | | 7.4 | 11.4 | 1 | 13 | 1 | 13 | | |
| t _{PLH} | $\overline{\text{CLR}}$ trigger | Q or \bar{Q} | C _L = 50 pF | 7.6 | 14.9 | 1 | 17 | 1 | 17 | ns | |
| t _{PHL} | | | | 8.7 | 14.9 | 1 | 17 | 1 | 17 | | |
| t _w [†] | | Q or \bar{Q} | C _L = 50 pF, C _{ext} = 28 pF, R _{ext} = 2 kΩ | 167 | 200 | | 240 | | 240 | ns | |
| | | | C _L = 50 pF, C _{ext} = 0.01 μF, R _{ext} = 10 kΩ | 90 | 100 | 110 | 90 | 110 | 90 | 110 | μs |
| | | | C _L = 50 pF, C _{ext} = 0.1 μF, R _{ext} = 10 kΩ | 0.9 | 1 | 1.1 | 0.9 | 1.1 | 0.9 | 1.1 | ms |
| Δt _w [‡] | | | | ±1 | | | | | | % | |

* On products compliant to MIL-PRF-38535, this parameter is not production tested.

[†] t_w = Duration of pulse at Q and \bar{Q} outputs

[‡] Δt_w = Output pulse-duration variation (Q and \bar{Q}) between circuits in same package

operating characteristics, V_{CC} = 5 V, T_A = 25°C

| PARAMETER | TEST CONDITIONS | TYP | UNIT |
|---|-----------------|-----|------|
| C _{pd} Power dissipation capacitance | No load | 29 | pF |



SN54AHC123A, SN74AHC123A DUAL RETRIGGERABLE MONOSTABLE MULTIVIBRATORS

SCLS352D – JULY 1997 – REVISED DECEMBER 1999

PARAMETER MEASUREMENT INFORMATION

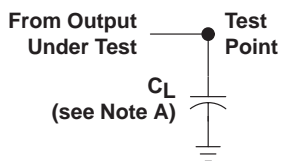

LOAD CIRCUIT

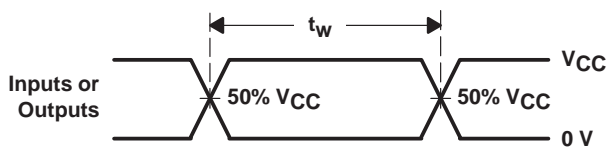

VOLTAGE WAVEFORMS
PULSE DURATION

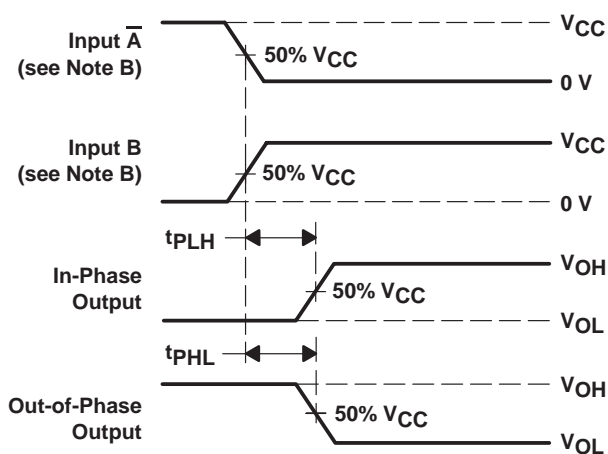

VOLTAGE WAVEFORMS
DELAY TIMES

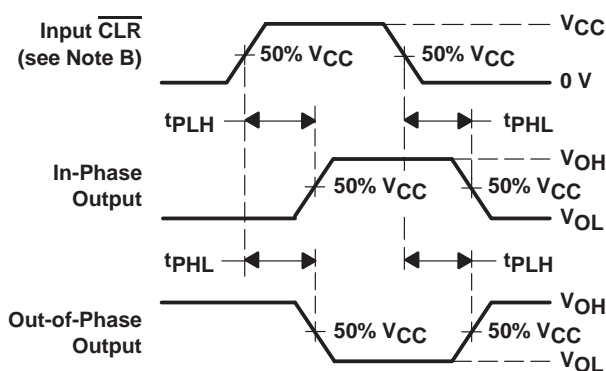

VOLTAGE WAVEFORMS
DELAY TIMES

- NOTES: A. C_L includes probe and jig capacitance.
 B. All input pulses are supplied by generators having the following characteristics: $Z_O = 50 \Omega$, $t_r = 3 \text{ ns}$, $t_f = 3 \text{ ns}$.
 C. The outputs are measured one at a time with one input transition per measurement.

Figure 1. Load Circuit and Voltage Waveforms

APPLICATION INFORMATION

caution in use

To prevent malfunctions due to noise, connect a high-frequency capacitor between V_{CC} and GND, and keep the wiring between the external components and C_{ext} and R_{ext}/C_{ext} terminals as short as possible.

power-down considerations

Large values of C_{ext} can cause problems when powering down the 'AHC123A because of the amount of energy stored in the capacitor. When a system containing this device is powered down, the capacitor can discharge from V_{CC} through the protection diodes at pin 2 or pin 14. Current through the input protection diodes must be limited to 30 mA; therefore, the turn-off time of the V_{CC} power supply must not be faster than $t = V_{CC} \times C_{ext}/30 \text{ mA}$. For example, if $V_{CC} = 5 \text{ V}$ and $C_{ext} = 15 \text{ pF}$, the V_{CC} supply must turn off no faster than $t = (5 \text{ V}) \times (15 \text{ pF})/30 \text{ mA} = 2.5 \text{ ms}$. Usually, this is not a problem because power supplies are heavily filtered and cannot discharge at this rate. When a more rapid decrease of V_{CC} to zero occurs, the 'AHC123A can sustain damage. To avoid this possibility, use external clamping diodes.

output pulse duration

The output pulse duration, t_w , is determined primarily by the values of the external capacitance (C_T) and timing resistance (R_T). The timing components are connected as shown in Figure 2.

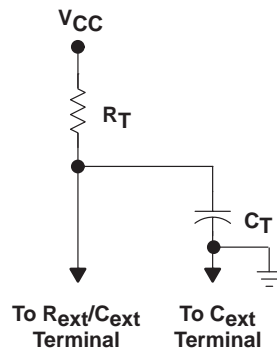

Figure 2. Timing-Component Connections

The pulse duration is given by:

$$t_w = K \times R_T \times C_T \tag{1}$$

if C_T is $\geq 1000 \text{ pF}$, $K = 1.0$ or
 if C_T is $< 1000 \text{ pF}$, K can be determined from Figure 5

where:

- t_w = pulse duration in ns
- R_T = external timing resistance in $k\Omega$
- C_T = external capacitance in pF
- K = multiplier factor

Equation 1 and Figure 3 can be used to determine values for pulse duration, external resistance, and external capacitance.

SN54AHC123A, SN74AHC123A DUAL RETRIGGERABLE MONOSTABLE MULTIVIBRATORS

SCLS352D – JULY 1997 – REVISED DECEMBER 1999

retriggering data

The minimum input retriggering time (t_{MIR}) is the minimum time required after the initial signal before retriggering the input. After t_{MIR} , the device retriggers the output. Experimentally, it also can be shown that to retrigger the output pulse, the two adjacent input signals should be t_{MIR} apart, where $t_{MIR} = 0.30 \times t_w$. The retrigger pulse duration is calculated as shown in Figure 3.

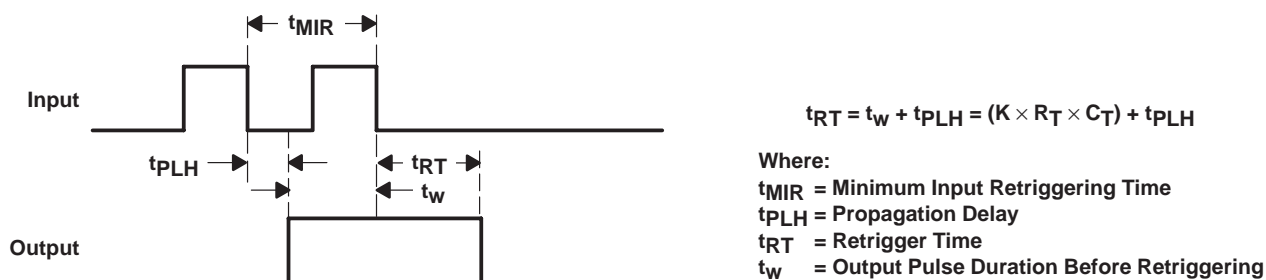
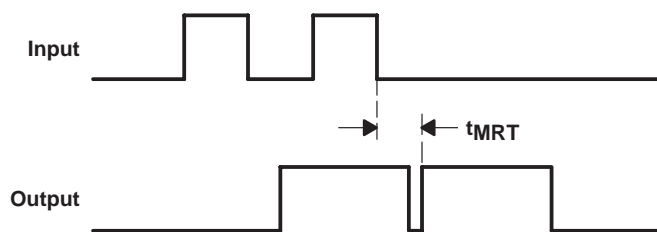

Figure 3. Retrigger Pulse Duration

The minimum value from the end of the input pulse to the beginning of the retriggered output should be approximately 15 ns to ensure a retriggered output. This is illustrated in Figure 4.



t_{MRT} = Minimum Time Between the End of the Second Input Pulse and the Beginning of the Retriggered Output
 $t_{MRT} = 15 \text{ ns}$

Figure 4. Input/Output Requirements

APPLICATION INFORMATION†

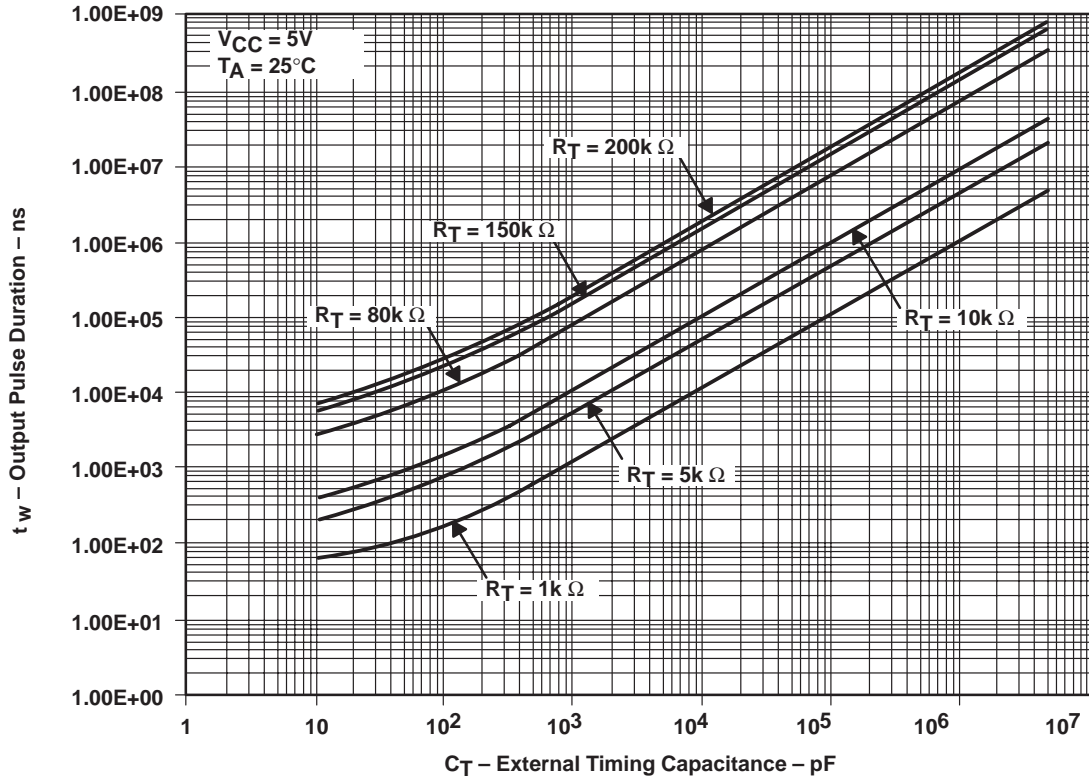

Figure 5. Output Pulse Duration vs External Timing Capacitance

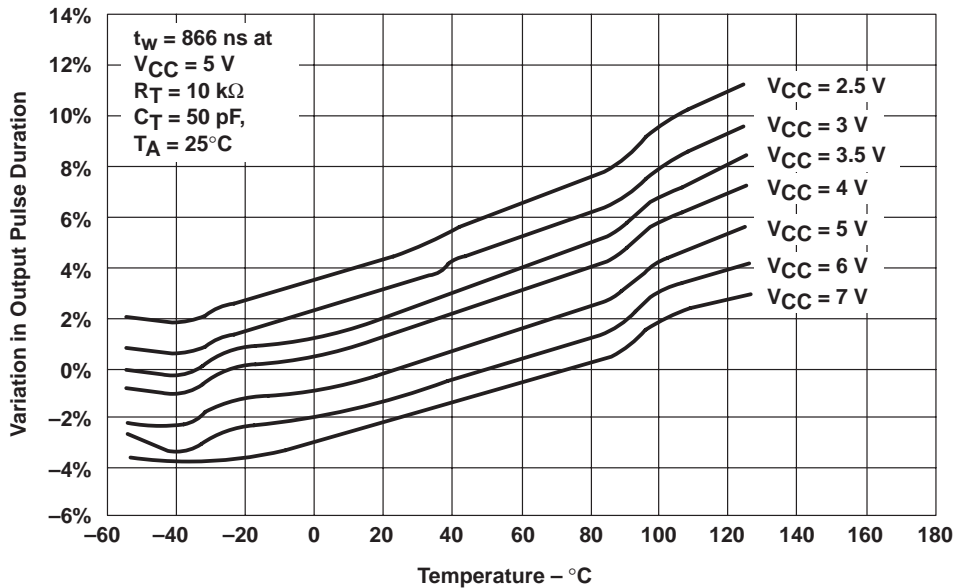

Figure 6. Variations in Output Pulse Duration vs Temperature

† Operation of the device at these or any other conditions beyond those indicated under "recommended operating conditions" is not implied.

SN54AHC123A, SN74AHC123A DUAL RETRIGGERABLE MONOSTABLE MULTIVIBRATORS

SCLS352D – JULY 1997 – REVISED DECEMBER 1999

APPLICATION INFORMATION†

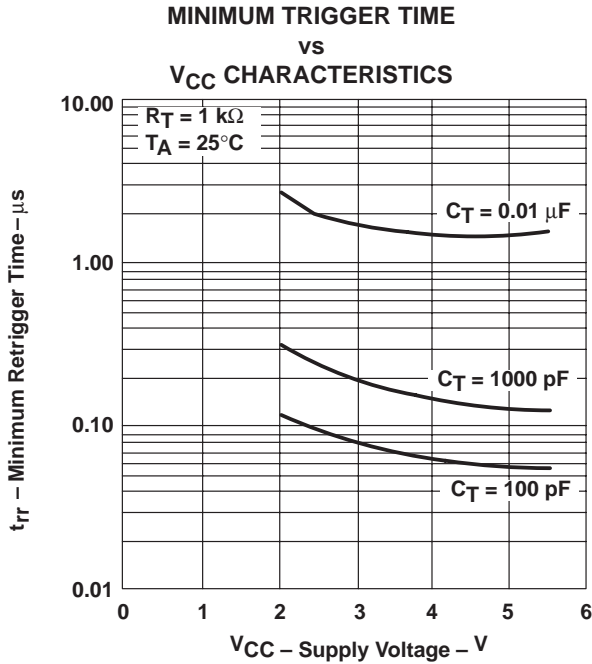

Figure 7

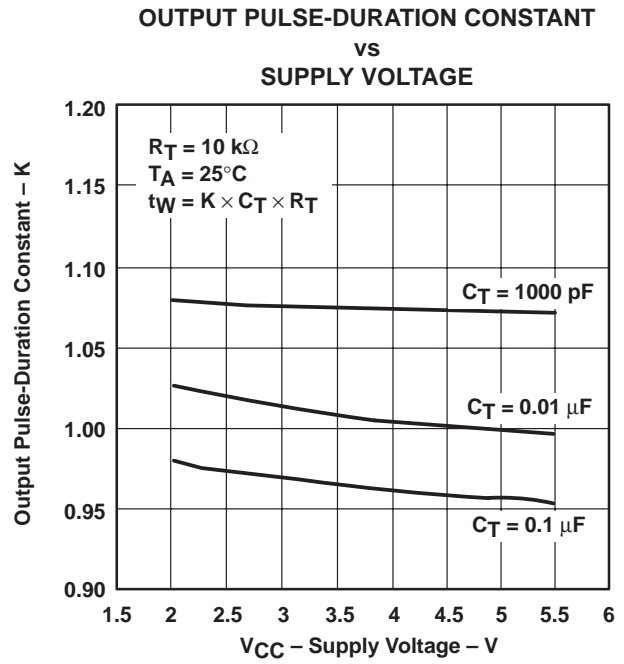

Figure 8

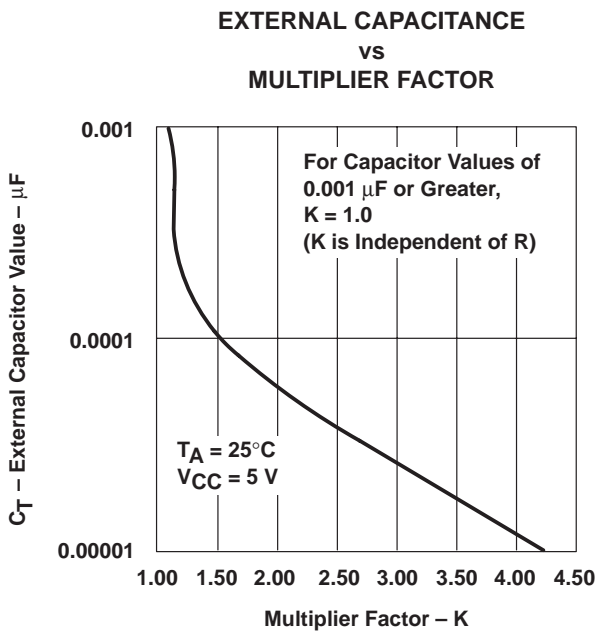

Figure 9

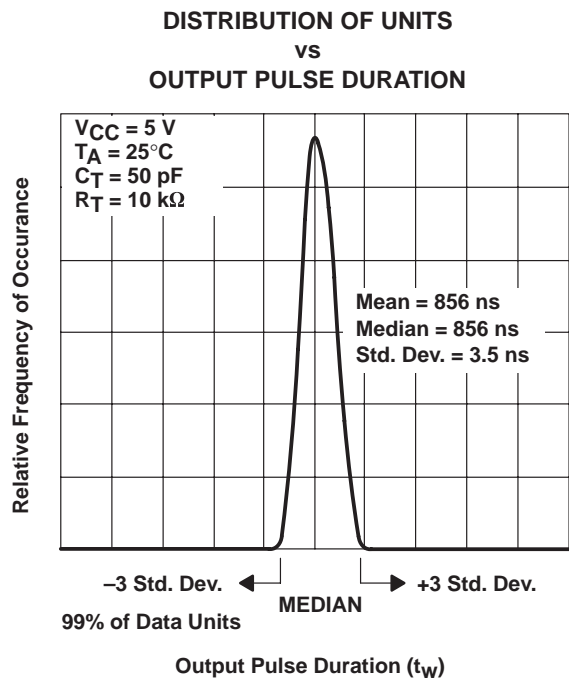

Figure 10

† Operation of the device at these or any other conditions beyond those indicated under "recommended operating conditions" is not implied.



IMPORTANT NOTICE

Texas Instruments and its subsidiaries (TI) reserve the right to make changes to their products or to discontinue any product or service without notice, and advise customers to obtain the latest version of relevant information to verify, before placing orders, that information being relied on is current and complete. All products are sold subject to the terms and conditions of sale supplied at the time of order acknowledgement, including those pertaining to warranty, patent infringement, and limitation of liability.

TI warrants performance of its semiconductor products to the specifications applicable at the time of sale in accordance with TI's standard warranty. Testing and other quality control techniques are utilized to the extent TI deems necessary to support this warranty. Specific testing of all parameters of each device is not necessarily performed, except those mandated by government requirements.

CERTAIN APPLICATIONS USING SEMICONDUCTOR PRODUCTS MAY INVOLVE POTENTIAL RISKS OF DEATH, PERSONAL INJURY, OR SEVERE PROPERTY OR ENVIRONMENTAL DAMAGE ("CRITICAL APPLICATIONS"). TI SEMICONDUCTOR PRODUCTS ARE NOT DESIGNED, AUTHORIZED, OR WARRANTED TO BE SUITABLE FOR USE IN LIFE-SUPPORT DEVICES OR SYSTEMS OR OTHER CRITICAL APPLICATIONS. INCLUSION OF TI PRODUCTS IN SUCH APPLICATIONS IS UNDERSTOOD TO BE FULLY AT THE CUSTOMER'S RISK.

In order to minimize risks associated with the customer's applications, adequate design and operating safeguards must be provided by the customer to minimize inherent or procedural hazards.

TI assumes no liability for applications assistance or customer product design. TI does not warrant or represent that any license, either express or implied, is granted under any patent right, copyright, mask work right, or other intellectual property right of TI covering or relating to any combination, machine, or process in which such semiconductor products or services might be or are used. TI's publication of information regarding any third party's products or services does not constitute TI's approval, warranty or endorsement thereof.