

Block diagram

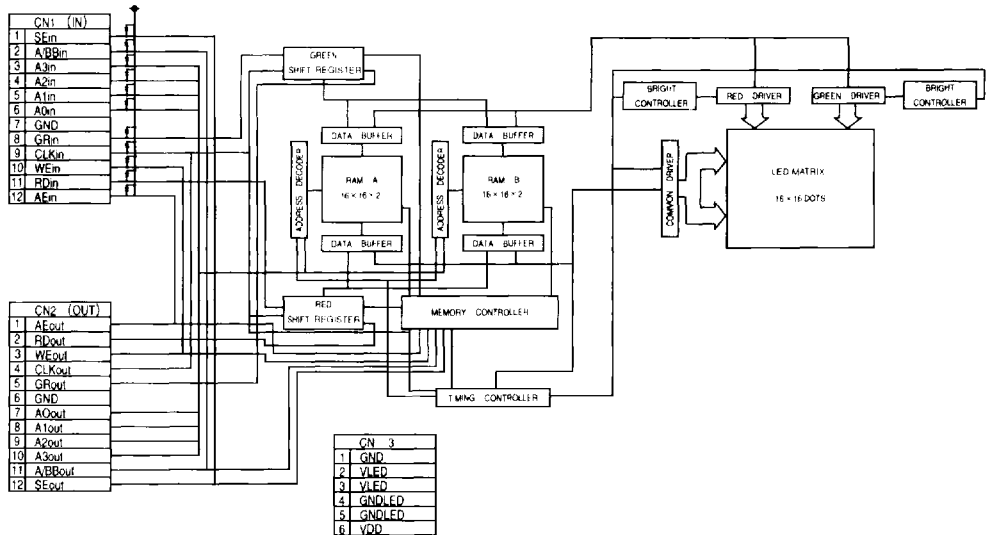

Table 1 Pin description

Pin no.	Pin name	Pin description
CN-1		
11	RDin	Data input for red LED. LED is on when this pin is HIGH, and off when this pin is LOW.
8	GRin	Data input for green LED. LED is on when this pin is HIGH, and off when this pin is LOW.
9	CLKin	Clock input. Data are fetched in the internal shift register at the leading edge of CLK. (Common signal of dynamic lighting up is obtained by dividing the CLK signal frequency.)
3 ~ 6	A0in-A3 in	RAM address input. Specified the address of the memory where the display data is written.
10	WEin	Write control signal. The contents of the internal shift register are written to memory when this signal is HIGH. (Effective only when AEin is HIGH.)
12	AEin	Address control signal. When HIGH, A0in-A3 are specified.
2	A/BBin	Selection control signal of the memory where data is to be written. ARAM is selected when this pin is HIGH, and BRAM is selected when this pin is LOW. (This signal is effective only when SEin is HIGH.) The contents of the memory not specified for writing are displayed.
1	SEin	This signal switches the internal/external selection of the memory. Switching of ARAM and BRAM is carried out by using the A/BBin signal. Data of BRAM are displayed when ARAM is specified for writing, and data of ARAM are displayed when BRAM is specified for writing. When this pin is LOW, data are written to the last address (15th address) of the memory and after that data are written from the 0th address of another memory. Displayed data are changed when the memory changes.

Table 1 Pin description

Pin no.	Pin name	Pin description
7	GND	
CN-2		
2	RDout	Red LED display data output. Signal passing through the internal 16-bit shift register is outputted in synchronism with the CLK signal. When connecting the LED modules in series, connect this pin to the RDin pin of the next module.
5	GRout	Green LED display data output. Signal passing through the internal 16-bit shift register is outputted in synchronism with the CLK signal. When connecting the LED modules in series, connect this pin to the GRin pin of the next module.
4	CLKout	CLK signal output. The CLKin signal is outputted. This pin is connected to the CLKin pin of the next module.
7 ~ 10	A0-A3out	Address signal output. The A0in-A3 in signals are outputted. These pins are connected to the A0in-A3 pin on the next module.
3	WEout	WE (write control) signal output. The WEin signal is outputted. Connect this pin to the WEin pin of the next module.
1	AEout	AE (address control) signal output. The AEin signal is outputted. Connect this pin to the AEin pin of the next module.
11	A/BBout	A/BB (write memory selection) signal output. The A/BBin signal is outputted. This pin is connected to the A/BBin pin on the next module.
12	SEout	SE (memory selection control) signal output. The SEin signal is outputted. This pin is connected to the SEin pin on the next module.
7	GND	
CN-3		
1	GND	Logic GND
2, 3	VLED	Supply voltage for LED
4, 5	GND LED	LED, GND
6	VDD	Supply voltage for LOGIC

Recommended operating conditions

Parameter	Symbol	Min	Typical	Max	Unit	Conditions
Power supply, control	V _{DD}		5.0		V	
Power supply, LEDs	V _{LED}		5.0		V	
High level control input voltage	V _{IH}	4.5		5.0	V	V _{CC} = V _{LED} = 5.0 V
Low level control input voltage	V _{IL}	0		1.0	V	V _{CC} = V _{LED} = 5.0 V

Electro-optical characteristics

Parameter	Symbol	Min	Typical	Max	Unit	Conditions
Luminance	I_V		750		cd/m ²	When orange displayed
Operating frequency				20	MHz	$V_{CC} = V_{LED} = 5.0\text{ V}$
Control circuit						
Power supply	V_{DD}		5.0		V	
Current consumption	I_{CC1}			20	mA	
Display circuit						
Power supply, LEDs	V_{LED}		5.0		V	
Current consumption	I_{CC2}			5.5	A	When orange displayed

Precaution for use

- Take care not to drop the LED panels or allow anything to drop onto the panels. Any shock can cause deformation of the surface, cracks in the solder or damage the LED elements.
- Take care keep these units cool. If necessary mount the units with fans to remove excess heat. If the LED panels are allowed to get too hot, this can cause a degradation in their luminosity.
- Use a stable power supply. If the voltage supply fluctuates, so will the brightness of the LEDs.
- When placing more LED panels together to form a composite panel, ensure that you consider the combined heat dissipation requirements and ensure that there is room in the housing for the expansion of the elements as they warm up.
- Do not rub the display unit surface. Do not use organic solvents such as paint thinners to clean the surface.
- Since these products use large scale integrated circuits, ensure that you protect the unit from electrostatic discharge when manufacturing panels, installing panels or maintaining panels.
- Be careful not to short circuit the terminations or apply excessive voltage to these panels
- Do not mount these units where they are exposed to wind or rain
- Be sure to ground the control circuit and the LED power close to the power equipment.
- Use a shielded cable to reduce the noise in the signaling cables, especially when using high frequency signaling or the cable between the controller and the LED panels is long.
- LEDs will lose intensity as they age. Be aware of this and do not leave the LEDs elements on the panels lit when not required. If one particular element is always on while other units change as the messages are generated, the lamp that is lit continuously will begin to fade with respect to the other LEDs. Be aware of this when designing the messages.

Timing diagram

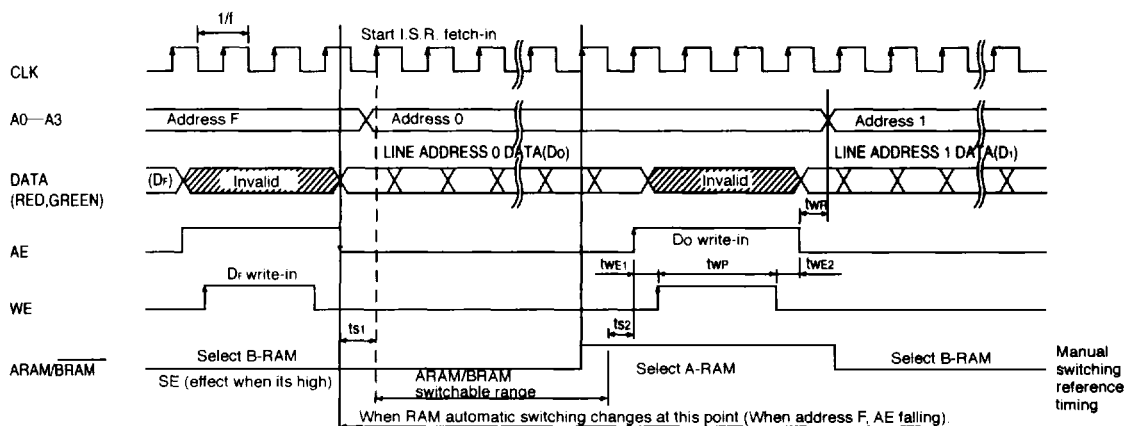

Table 2 Recommended operating conditions

Parameter	Symbol	Min	Typical	Max	Unit
Clock frequency	f			20	MHz
Address storage time	t _{WR}	15			ns
Address storage enable time (1)	t _{WE1}	50			ns
Address enable storage time (2)	t _{WE2}	30			ns
Write pulse time	t _{WP}	50			ns
RAM select time (1)	t _{S1}	15			ns
RAM select time (2)	t _{S2}	15			ns

Note 1: When AE is HIGH, displayed invalid RAM switching timing will be changed without relation to display.

Note 2: Display data are fetched on the rising edge of the clock signal, and are output on the falling edge.

Note 3: Data is not fetched while AEin is HIGH, output will store previous data.

Note 4: RAM is switched by A/BB (when SEin is HIGH) or by changing the address of A0~A3 from 15 to 0.