



SANYO Semiconductors

DATA SHEET

LC75396NE

CMOS IC



Single-Chip Electronic Volume Control System

Overview

The LC75396NE is an electronic volume control system providing control over volume, balance, 5-band equalizer, and input switching based on serial inputs.

Functions

- Volume control:
The chip provides 81 levels of volume attenuation: in 1-dB step between 0 dB and -79 dB and $-\infty$. Independent control over left front/rear and right front/rear channels provides balance control.
- Equalizer:
The chip provides control in 2-dB steps over the range between $+10$ dB and -10 dB. Four of the five bands have peaking equalization; the remaining one, shelving equalization.
- Selector:
The left and right channels each offer a choice of five inputs. The L5 and R5 inputs can be turned on and off independently. An external constant determines the amplification for the input signal.
- Serial data input
— Supports CCB* format communication with the system controller.

Features

- Built-in buffer amplifiers reduce the number of external parts required.
- Silicon gate CMOS process reduces the noise of built-in switch.
- $V_{DD}/2$ reference voltage generation circuit built in.

- CCB is a trademark of SANYO ELECTRIC CO., LTD.
- CCB is SANYO's original bus format and all the bus addresses are controlled by SANYO.

Specifications

Absolute Maximum Ratings at $T_a = 25^\circ\text{C}$, $V_{SS} = 0$ V

Parameter	Symbol	Conditions	Ratings	Unit
Maximum supply voltage	$V_{DD\ max}$	V_{DD}	11	V
Maximum input voltage	$V_{IK\ max}$	CL, DI, CE, L1 to L5, R1 to R5, LTIN, RTIN, LFIN, RFIN, LRIN, RRIN	$V_{SS} - 0.3$ to $V_{DD} + 0.3$	V
Allowable power dissipation	$P_d\ max$	$T_a \leq 75^\circ\text{C}$, with PC board	550	mW
Operating temperature	T_{opr}		-30 to $+75$	$^\circ\text{C}$
Storage temperature	T_{stg}		-40 to $+125$	$^\circ\text{C}$

■ Any and all SANYO Semiconductor products described or contained herein do not have specifications that can handle applications that require extremely high levels of reliability, such as life-support systems, aircraft's control systems, or other applications whose failure can be reasonably expected to result in serious physical and/or material damage. Consult with your SANYO Semiconductor representative nearest you before using any SANYO Semiconductor products described or contained herein in such applications.

■ SANYO Semiconductor assumes no responsibility for equipment failures that result from using products at values that exceed, even momentarily, rated values (such as maximum ratings, operating condition ranges, or other parameters) listed in products specifications of any and all SANYO Semiconductor products described or contained herein.

SANYO Semiconductor Co., Ltd.

TOKYO OFFICE Tokyo Bldg., 1-10, 1 Chome, Ueno, Taito-ku, TOKYO, 110-8534 JAPAN

LC75396NE

Allowable Operating Ranges at $T_a = -30$ to $+75^\circ\text{C}$, $V_{SS} = 0\text{ V}$

Parameter	Symbol	Conditions	Ratings			Unit
			min	typ	max	
Supply voltage	V_{DD}	V_{DD}	6.0		10.5	V
Input high level voltage	V_{IH}	CL, DI, CE	4.0		V_{DD}	V
Input low level voltage	V_{IL}	CL, DI, CE	V_{SS}		1.0	V
Input voltage amplitude	V_{IN}	CL, DI, CE, L1 to L5, R1 to R5, LTIN, RTIN, LFIN, RFIN, LRIN, RRIN	V_{SS}		V_{DD}	Vp-p
Input pulse width	t_{pw}	CL	1.0			μs
Setup time	t_{SETUP}	CL, DI, CE	1.0			μs
Hold time	t_{HOLD}	CL, DI, CE	1.0			μs
Operating frequency	fopg	CL			500	kHz

Electrical Characteristics at $T_a = 25^\circ\text{C}$, $V_{DD} = 10\text{ V}$, $V_{SS} = 0\text{ V}$

Parameter	Symbol	Conditions	Ratings			Unit
			min	typ	max	
[Input block]						
Input resistance	R_{in}	L1 to L5, R1 to R5		50		k Ω
Clipping level	V_{cl}	LSELO, RSELO: THD = 1.0%		3.00		Vrms
Output load resistance	R_L	LSELO, RSELO	10			k Ω
[Volume control block]						
Input resistance	R_{in}	LFIN, LRIN, RFIN, RRIN		100		k Ω
[Equalizer control block]						
Control range	G_{eq}	Max, boost/cut	± 8	± 10	± 12	dB
Step resolution	E_{step}		1	2	3	dB
Internal feedback resistance	R_{feed}		17	28	39	k Ω
[Overall characteristics]						
Total harmonic distortion	THD	$V_{IN} = 1\text{ Vrms}$, $f = 1\text{ kHz}$, with all controls flat overall			0.01	%
Crosstalk	CT	$V_{IN} = 1\text{ Vrms}$, $f = 1\text{ kHz}$, with all controls flat overall, $R_g = 1\text{ k}\Omega$	80			dB
Output noise voltage	V_{N1}	With all controls flat overall, BW = 20 to 20kHz		2.9		μV
	V_{N2}	GEQ F1 Band $\pm 10\text{ dB}$, With all controls overall, BW = 20 to 20kHz		17		μV
Output at maximum attenuation	V_{Omin}	$V_{IN} = 1\text{ Vrms}$, $f = 1\text{ kHz}$, main volume $-\infty$		-90		dB
Current drain	I_{DD}	$V_{DD} - V_{SS} = 10.5\text{ V}$		46.5	55.8	mA
Input high level current	I_{IH}	CL, DI, CE, $V_{IN} = 10.5\text{ V}$			10	μA
Input low level current	I_{IL}	CL, DI, CE, $V_{IN} = 0\text{ V}$	-10			μA

Package Dimensions

unit: mm

3159-QFP64E

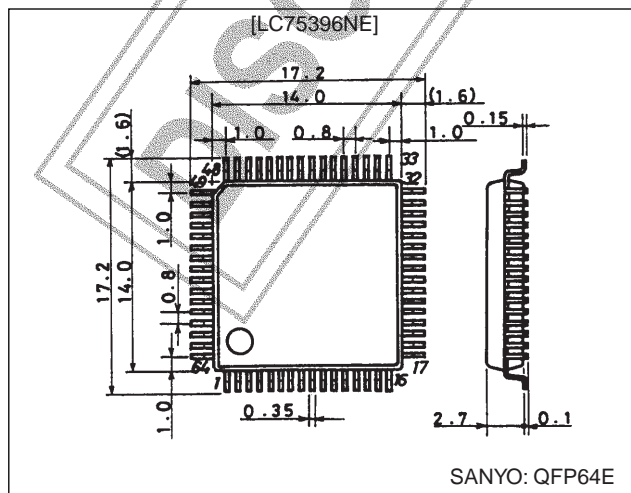

LC75396NE

Sample Application Circuit

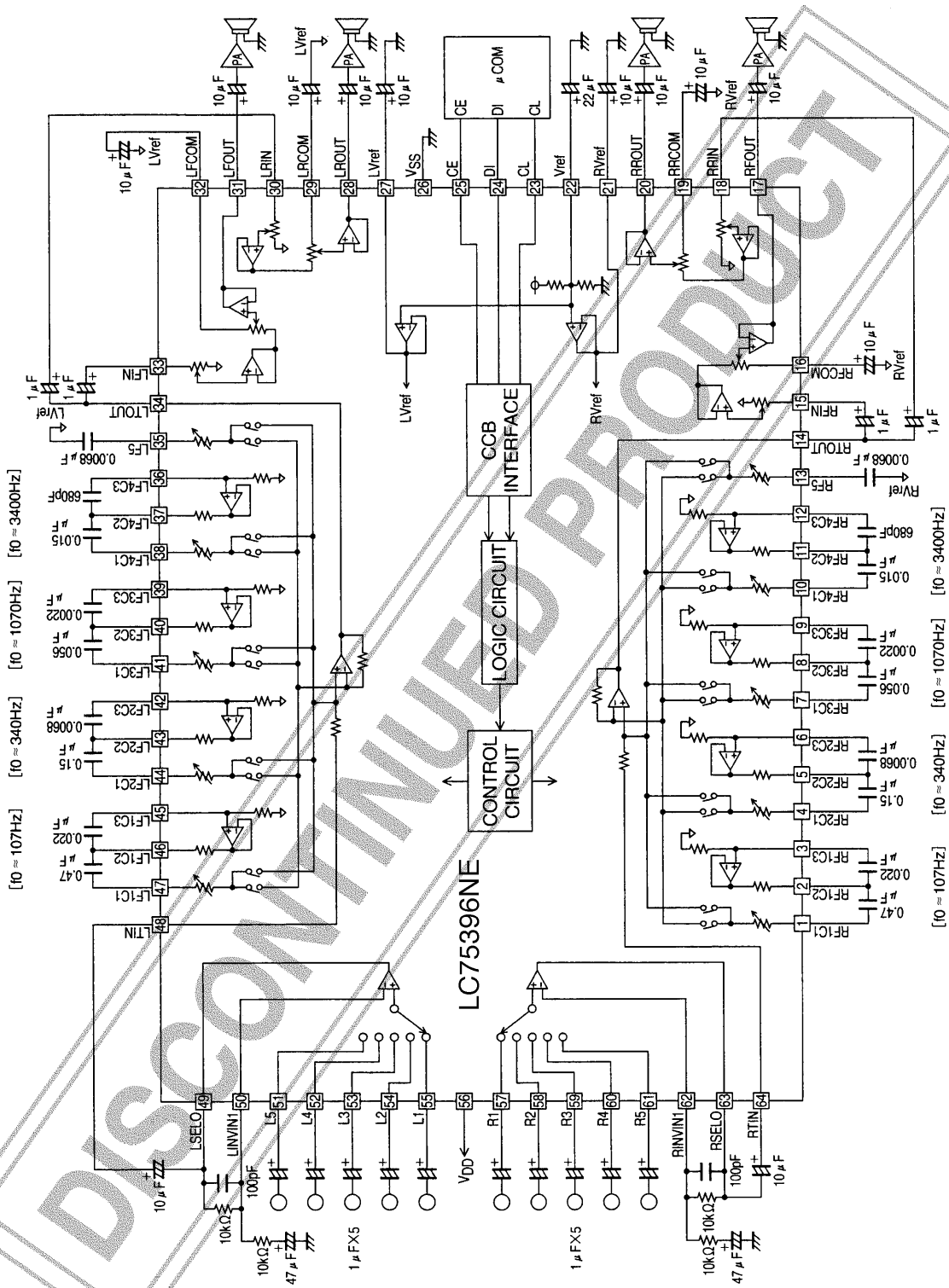

A08835

LC75396NE

Output Noise Voltage

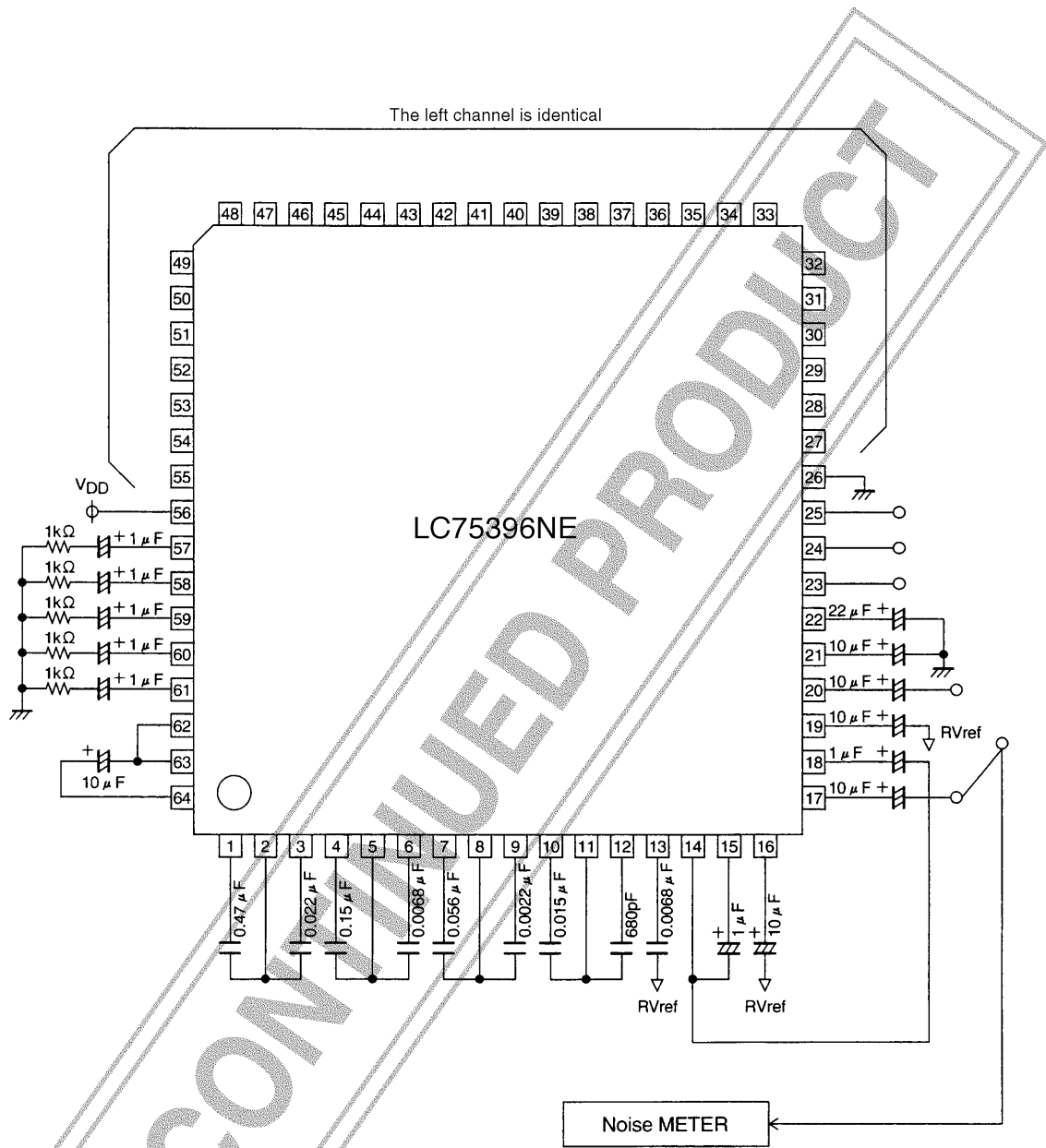

LC75396NE

Pin Assignment

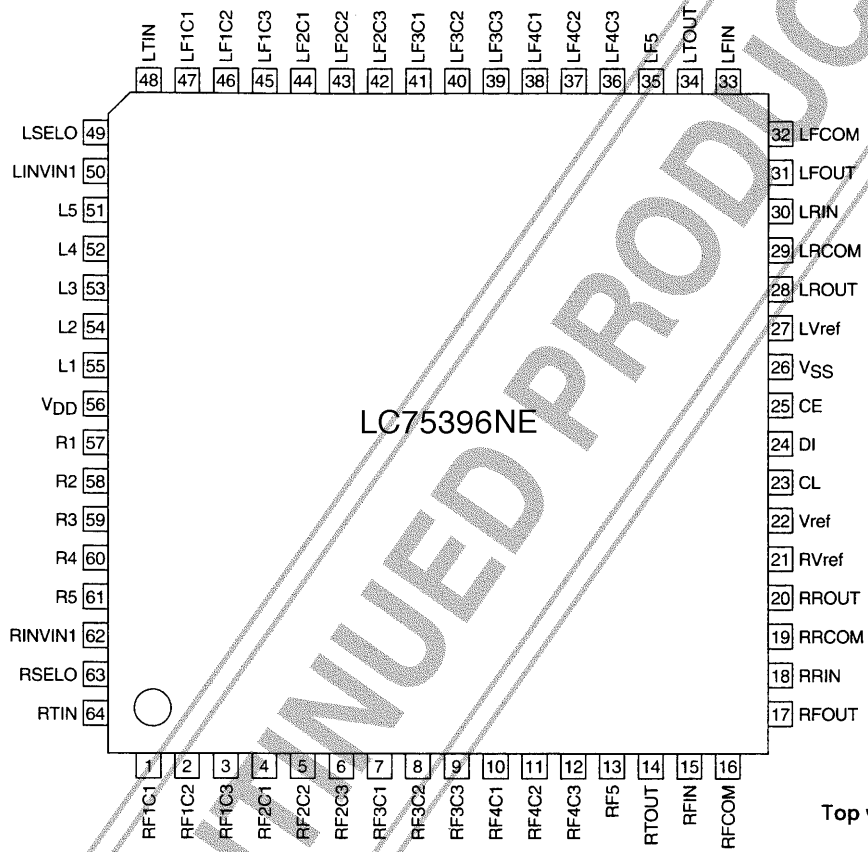

Top view

A08839

Pin Functions

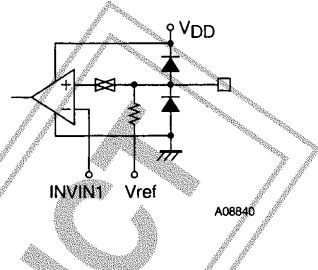
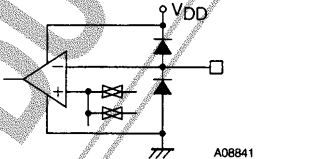
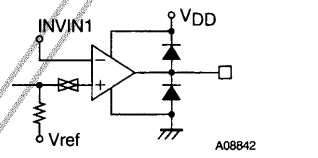
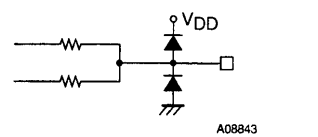
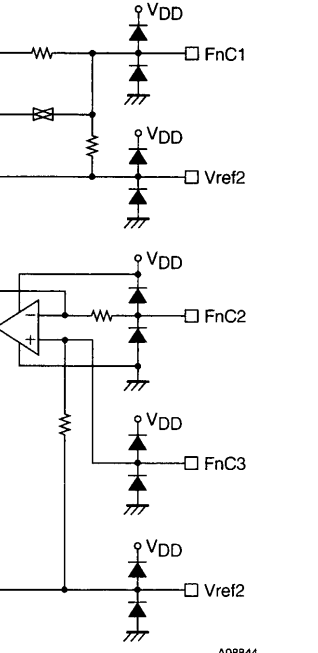
Pin No.	Pin	Function	Equivalent circuit
55 54 53 52 51 57 58 59 60 61	L1 L2 L3 L4 L5 R1 R2 R3 R4 R5	Signal inputs	
50 62	LINVIN1 RINVIN1	Inverting inputs to the operational amplifier that sets the input gain	
49 63	LSELO RSELO	Input selector outputs	
48 64	LTIN RTIN	Equalizer inputs	
47 46 45 1 2 3	LF1C1 LF1C2 LF1C3 RF1C1 RF1C2 RF1C3	<ul style="list-style-type: none"> Connections for the capacitors that form the equalizer F1 band filters Capacitors must be connected between: LF1C1 (RF1C1) and LF1C2 (RF1C2), and between LF1C2 (RF1C2) and LF1C3 (RF1C3): 	
44 43 42 4 5 6	LF2C1 LF2C2 LF2C3 RF2C1 RF2C2 RF2C3	<ul style="list-style-type: none"> Connections for the capacitors that form the equalizer F2 band filters Capacitors must be connected between: LF2C1 (RF2C1) and LF2C2 (RF2C2), and between LF2C2 (RF2C2) and LF2C3 (RF2C3). 	
41 40 39 7 8 9	LF3C1 LF3C2 LF3C3 RF3C1 RF3C2 RF3C3	<ul style="list-style-type: none"> Connections for the capacitors that form the equalizer F3 band filters Capacitors must be connected between: LF3C1 (RF3C1) and LF3C2 (RF3C2), and between LF3C2 (RF3C2) and LF3C3 (RF3C3). 	
38 37 36 10 11 12	LF4C1 LF4C2 LF4C3 RF4C1 RF4C2 RF4C3	<ul style="list-style-type: none"> Connections for the capacitors that form the equalizer F4 band filters Capacitors must be connected between: LF4C1 (RF4C1) and LF4C2 (RF4C2), and between LF4C2 (RF4C2) and LF4C3 (RF4C3). 	

Continued on next page.

LC75396NE

Continued from preceding page.

Pin No.	Pin	Function	Equivalent circuit
35 13	LF5 RF5	<ul style="list-style-type: none"> Connections for the capacitors that form the equalizer F5 band filters Connections for external capacitors 	<p style="text-align: right;">A08845</p>
33 30 15 18	LFIN LRIN RFIN RRIN	<ul style="list-style-type: none"> Input to the left channel front 4-dB step volume control. Input to the left channel rear 4-dB step volume control. Input to the right channel front 4-dB step volume control. Input to the right channel rear 4-dB step volume control. 	<p style="text-align: right;">A08846</p>
32 29 16 19	LFCOM LRCOM RFCOM RRCOM	<ul style="list-style-type: none"> Common pin for the left channel front 1-dB step volume control. Common pin for the left channel rear 1-dB step volume control. Common pin for the right channel front 1-dB step volume control. Common pin for the right channel rear 1-dB step volume control. 	
31 28 17 20	LFOUT LROUT RFOUT RROUT	<ul style="list-style-type: none"> Left channel front volume control output Left channel rear volume control output Right channel front volume control output Right channel rear volume control output 	<p style="text-align: right;">A08847</p>
34 14	LTOUT RTOUT	<ul style="list-style-type: none"> Equalizer outputs 	<p style="text-align: right;">A08848</p>
22	Vref	<ul style="list-style-type: none"> A capacitor of a few tens of μF must be inserted between Vref and AV_{SS} (V_{SS}) to handle power supply ripple in the $\text{V}_{\text{DD}}/2$ voltage generation circuit. 	<p style="text-align: right;">A08849</p>
27 21	LVref RVref	<ul style="list-style-type: none"> Internal analog system grounds 	<p style="text-align: right;">A08850</p>
56	V_{DD}	<ul style="list-style-type: none"> Power supply 	
26	V_{SS}	<ul style="list-style-type: none"> Ground 	
25	CE	<ul style="list-style-type: none"> Chip enable When this pin goes from high to low, data is written to an internal latch and the analog switches operate. Data transfers are enabled when this pin is at the high level. 	<p style="text-align: right;">A08851</p>
24 23	DI CL	<ul style="list-style-type: none"> Serial data and clock inputs for chip control. 	

Equivalent Circuit Diagram

Selector Control Block

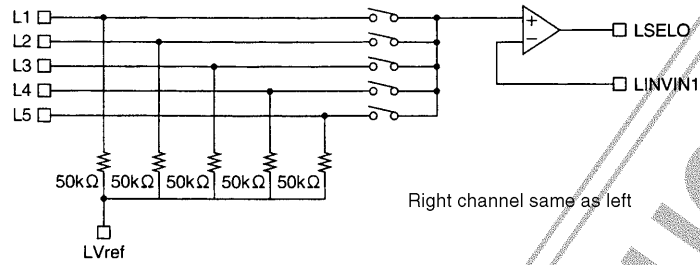

A08852

Equalizer Control Block

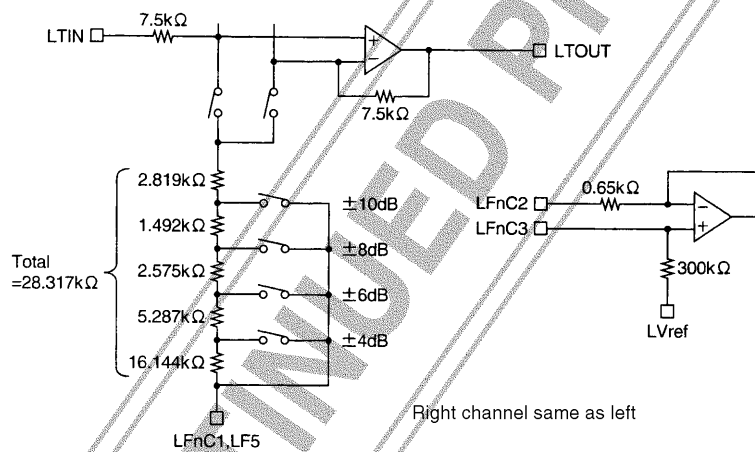

A08853

DISCONTINUED PRODUCT

Volume Control Block

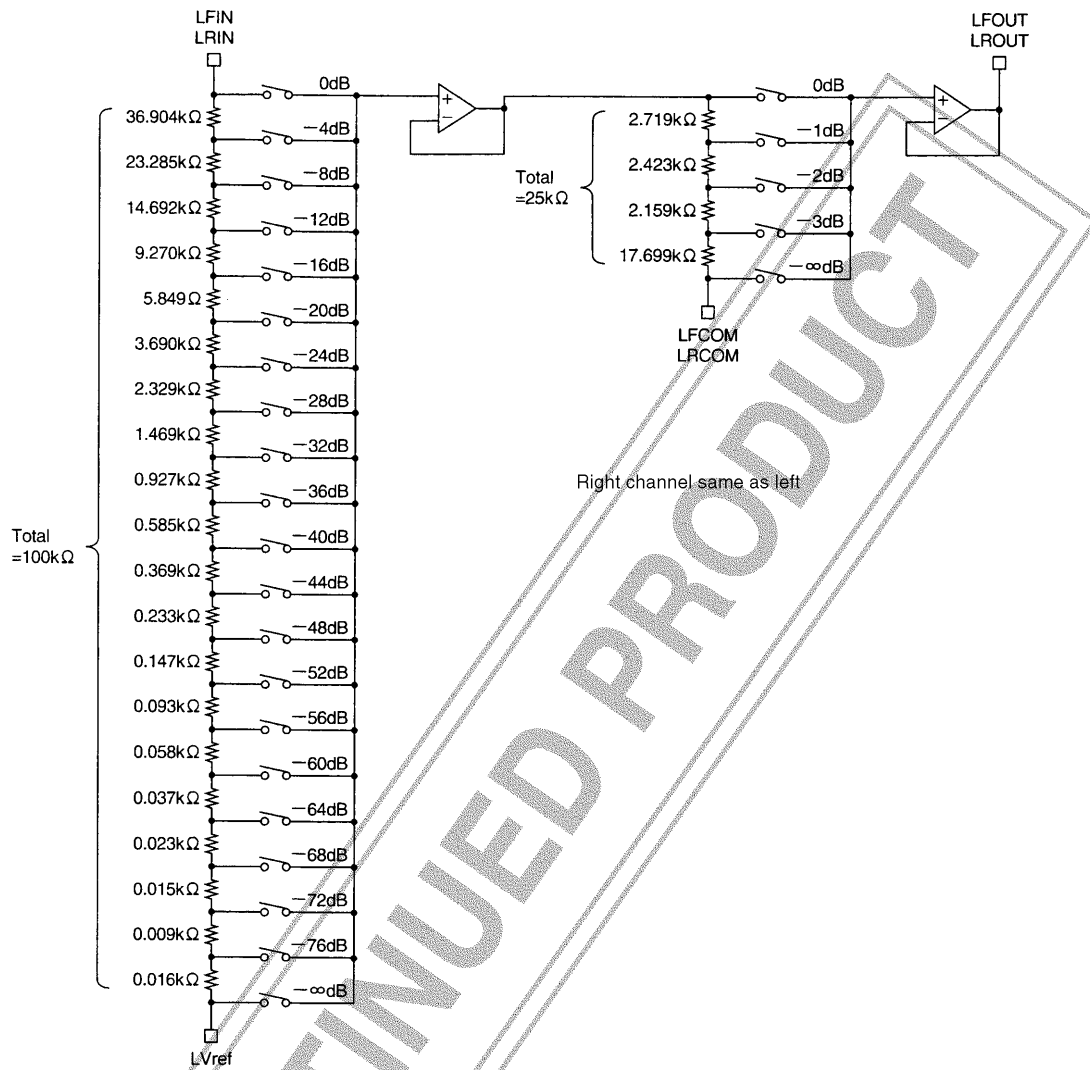

Calculating the Size of External Capacitors

The LC75396NE supports four bands with peaking characteristics and one band with shelving characteristics

1. Peaking Characteristics (bands F1 to F4)

The external capacitor functions as the structural element of a simulated inductor. The equivalent circuit and the calculations required to achieve the desired center frequency are shown below.

- Equivalent circuit for the simulated inductor

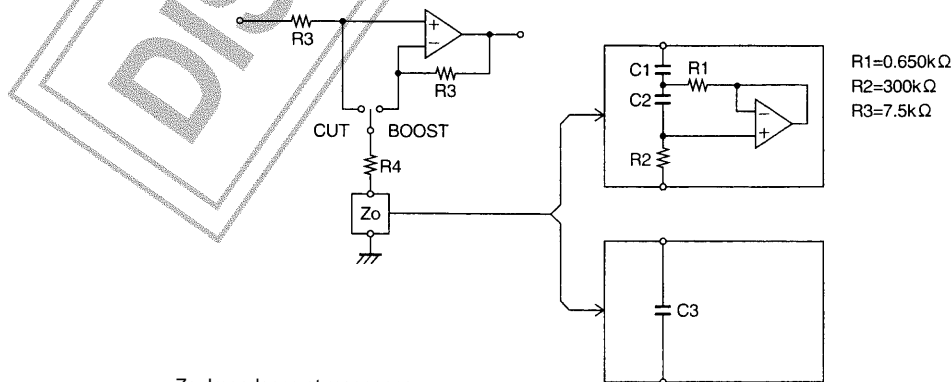

Zo: Impedance at resonance

A08855

• Calculation example

Specifications: Central frequency, $F_O = 107 \text{ Hz}$

Q factor at maximum boost, $Q_{+10 \text{ dB}} = 0.8$

— Calculate Q_O , the sharpness of the simulated inductance itself.

$$Q_O = (R1 + R4)/R1 \times Q_{+10 \text{ dB}} \approx 4.270$$

Note: R4 is from the separately issued internal block diagram.

— Calculate C1

$$C1 = 1/2\pi F_O R1 Q_O \approx 0.536 \text{ } (\mu\text{F})$$

— Calculate C2

$$C2 = Q_O/2\pi F_O R2 \approx 0.021 \text{ } (\mu\text{F})$$

• Sample results

Central frequency F_O (Hz)	C1 (F)	C2 (F)
107	0.536 μ	0.021 μ
340	0.169 μ	6663 p
1070	0.054 μ	2117 p
3400	0.017 μ	666 p

2. Shelving characteristics (Band F5)

Achieving the desired control of 2-dB steps over the range between +10 dB to -10 dB requires choosing a capacitor, C3, with an impedance of 650 Ω .

Control System Timing and Data Formats

To control the LC75396NE, specified sequences are required to be input through the pins CE, CL, and DI. Each sequence consists of 48 bits: an 8-bit address followed by 40 bits of data.

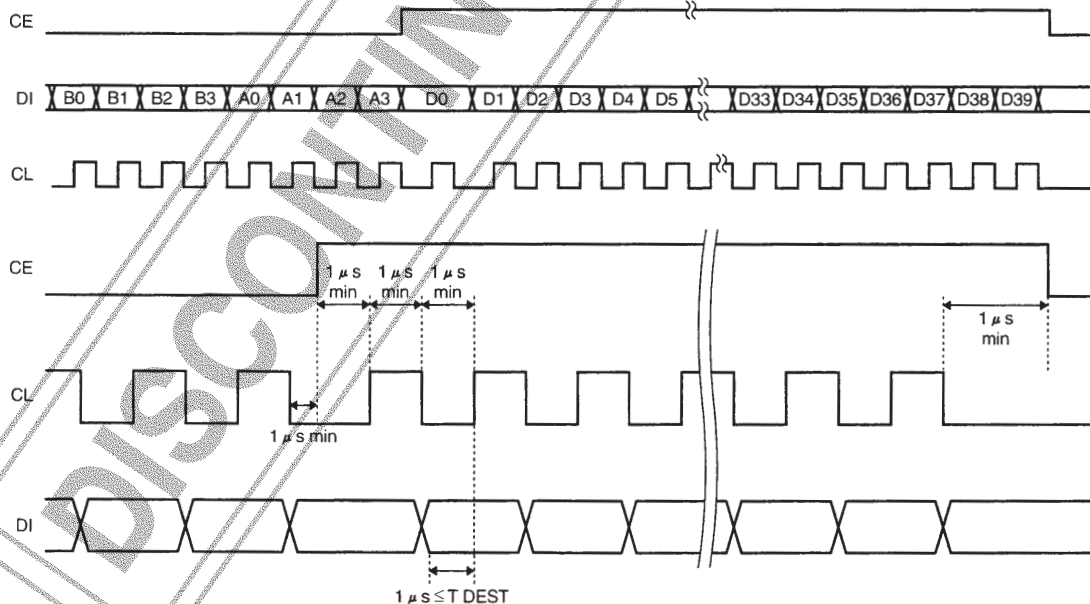

A08856

1. Address Code (B0 to A3)

This product uses an 8-bit address code, and supports the same specifications as other Sanyo CCB serial bus products.

Address code (LSB)

B0	B1	B2	B3	A0	A1	A2	A3	
0	1	0	0	0	0	0	1	(82HEX)

2. Control Code Allocations

Input switching control

D0	D1	D2	Operation	
0	0	0	L1 (R1)	ON
1	0	0	L2 (R2)	ON
0	1	0	L3 (R3)	ON
1	1	0	L4 (R4)	ON
0	0	1		OFF
1	0	1		OFF
0	1	1		OFF
1	1	1		OFF

Input switching control

D3	Operation	
0	L5 (R5)	OFF
1	L5 (R5)	ON

Five band equalizer control

D4	D5	D6	D7	Band f1
D8	D9	D10	D11	Band f2
D12	D13	D14	D15	Band f3
D16	D17	D18	D19	Band f4
D20	D21	D22	D23	Band f5
1	0	1	0	+10dB
0	0	1	0	+8dB
1	1	0	0	+6dB
0	1	0	0	+4dB
1	0	0	0	+2dB
0	0	0	0	0dB
1	0	0	1	-2dB
0	1	0	1	-4dB
1	1	0	1	-6dB
0	0	1	1	-8dB
1	0	1	1	-10dB

Volume control

D24	D25	D26	D27	D28	D29	D30	D31	Operation
								1dB STEP
0	0							0dB
1	0							-1dB
0	1							-2dB
1	1							-3dB
								4dB STEP
		0	0	0	0	0	0	0dB
		1	0	0	0	0	0	-4dB
		0	1	0	0	0	0	-8dB
		1	1	0	0	0	0	-12dB
		0	0	1	0	0	0	-16dB
		1	0	1	0	0	0	-20dB
		0	1	1	0	0	0	-24dB
		1	1	1	0	0	0	-28dB
		0	0	0	1	0	0	-32dB
		1	0	0	1	0	0	-36dB
		0	1	0	1	0	0	-40dB
		1	1	0	1	0	0	-44dB
		0	0	1	1	0	0	-48dB
		1	0	1	1	0	0	-52dB
		0	1	1	1	0	0	-56dB
		1	1	1	1	0	0	-60dB
		0	0	0	0	1	0	-64dB
		1	0	0	0	1	0	-68dB
		0	1	0	0	1	0	-72dB
		1	1	0	0	1	0	-76dB
								MUTE
		1	1	1	1	1	0	-∞

Channel selection control

D32	D33	Operation
0	0	Initial setting
1	0	RCH
0	1	LCH
1	1	Simultaneous left and right

Left channel volume rear/front control

D34	Operation
0	Rear
1	Front

Control is enabled when D33 = 1

Right channel volume rear/front control

D35	Operation
0	Rear
1	Front

Control is enabled when D32 = 1

Test mode control

D36	D37	D38	D39	Operation
0	0	0	0	These bits are for chip testing and must all be set to 0 in application systems.

Notes: After power is first applied, applications must initialize this chip by sending the initial data (1) and (2) described below.

Initial data ... (1) Address 01000001

Data: (Set the volume to -∞ set both D34 and D35 to 1, and set all other data to 0)

(2) Address 01000001

Data: (Set the volume to -∞, set both D34 and D35 to 0, and set all other data to 0)

After transferring that data, set the left and right channel initial settings before turning off the mute function.

f_0 (Center Frequency) Characteristics

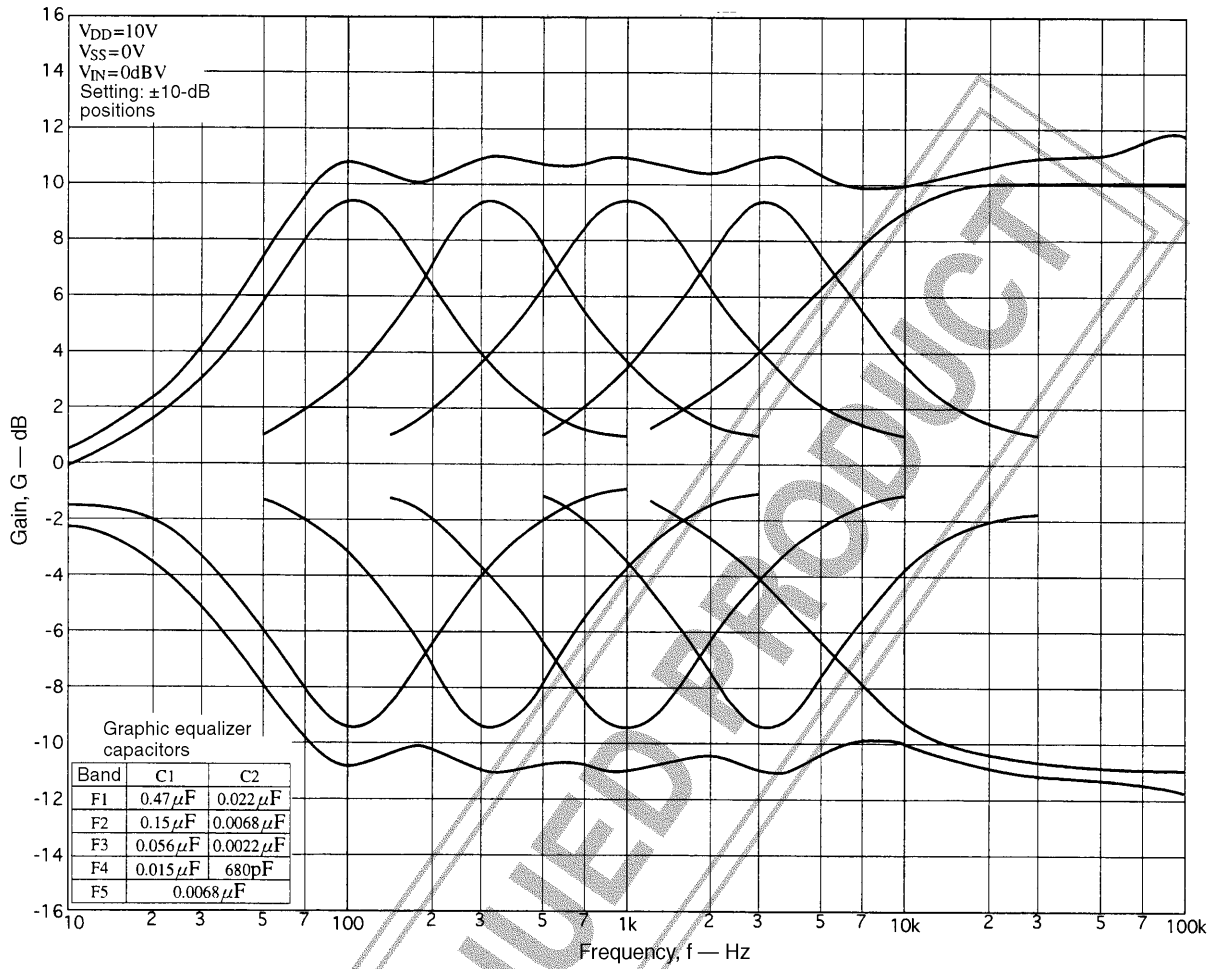

Volume Step Characteristics

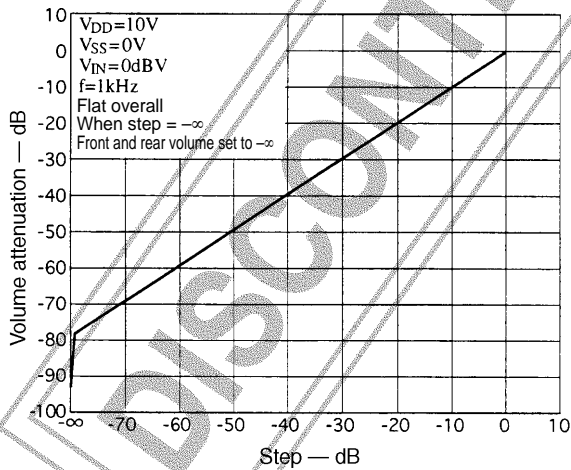

THD — Frequency Characteristics (1)

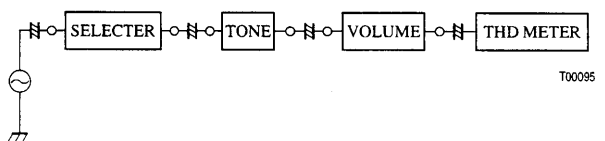
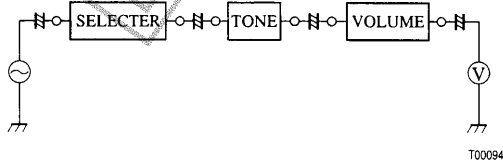
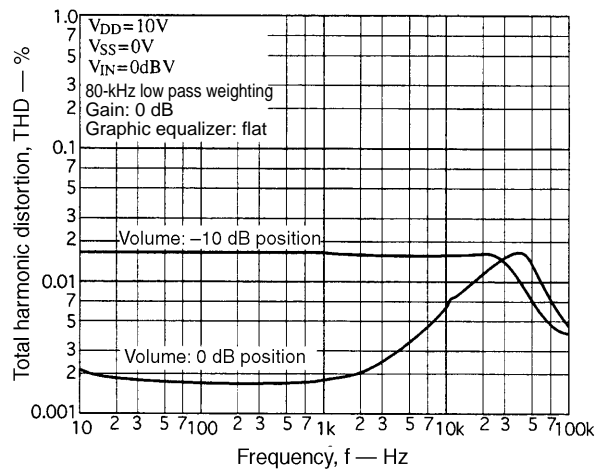

THD – Frequency Characteristics (2)

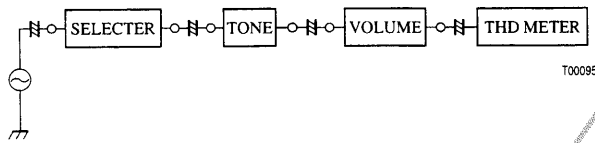
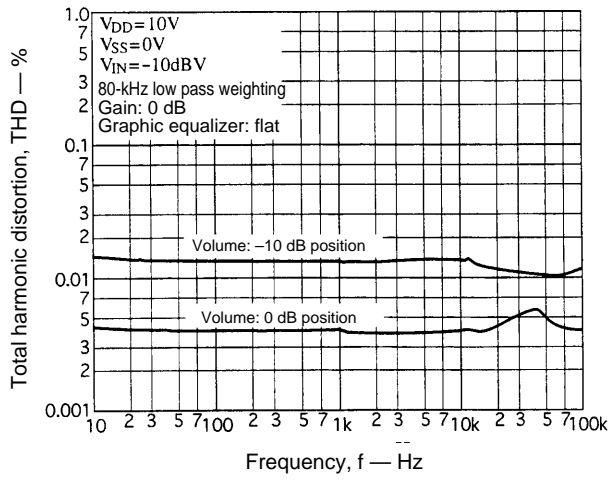

THD – Frequency Characteristics (3)

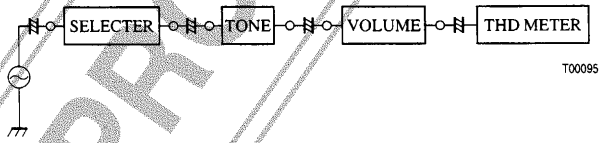
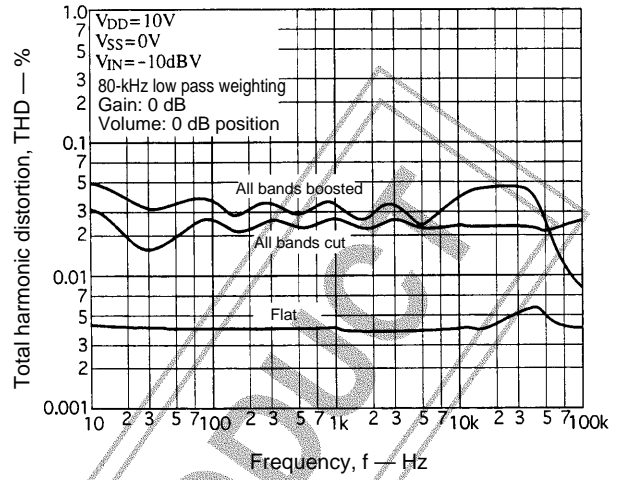

THD – Supply Voltage Characteristics (1)

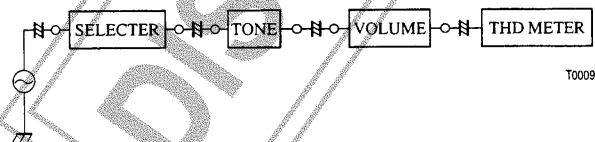
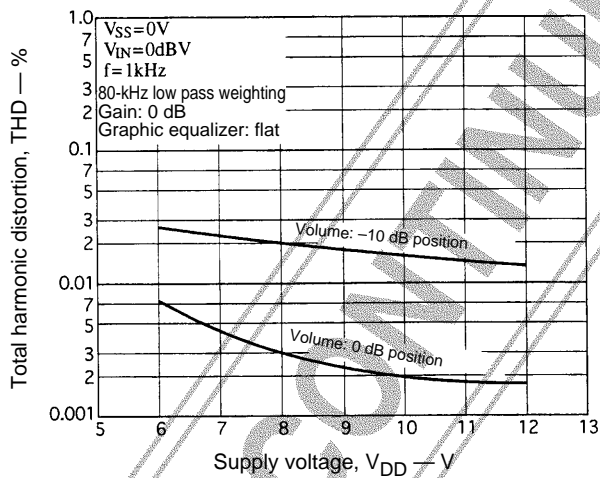

THD – Supply Voltage Characteristics (1)

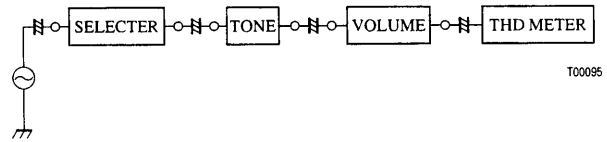
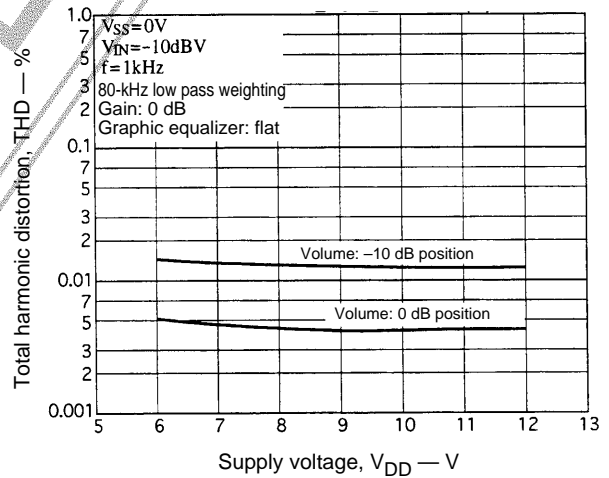

THD – Supply Voltage Characteristics (3)

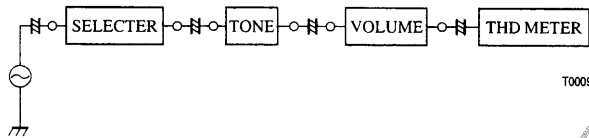
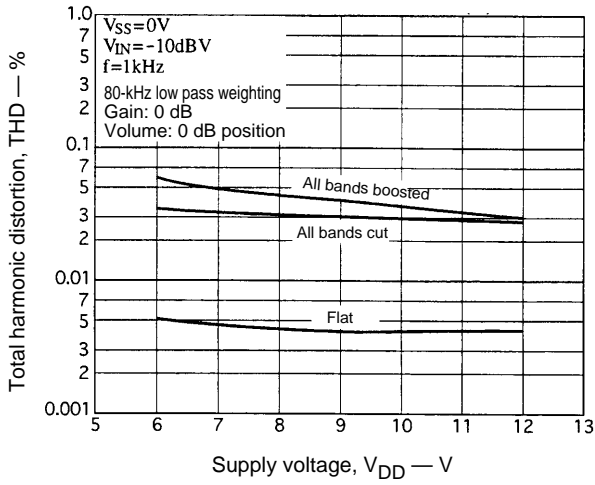

T00095

THD – Input Level Characteristics (1)

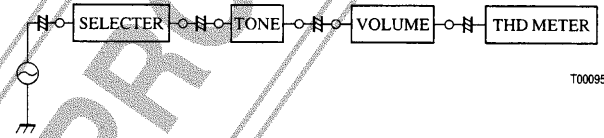
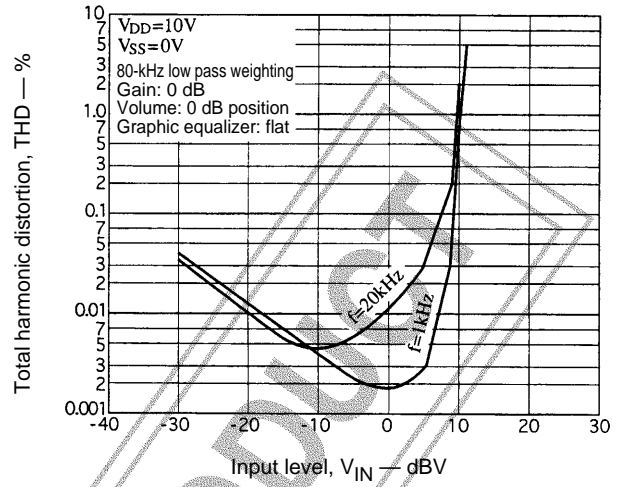

T00095

THD – Input Level Characteristics (2)

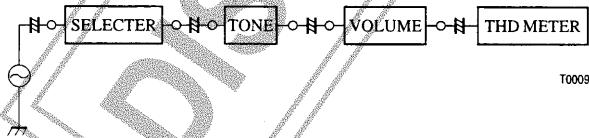
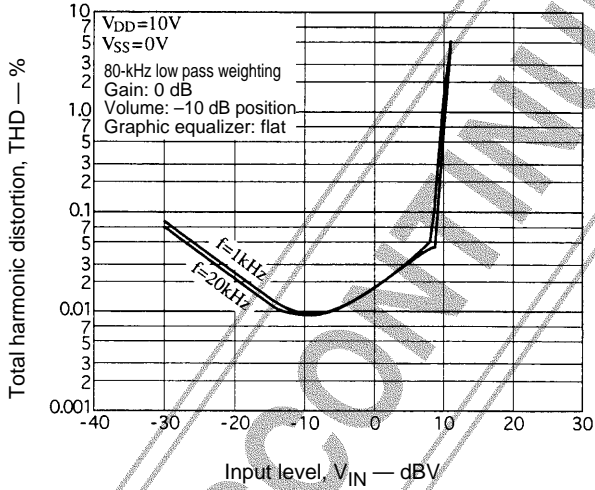

T00095

THD – Input Level Characteristics (3)

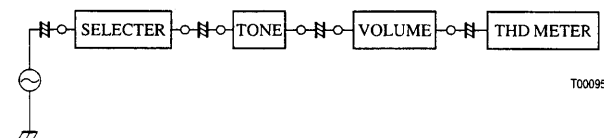
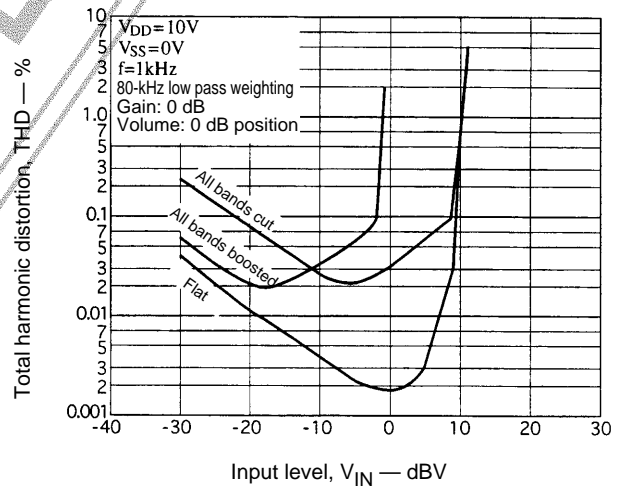

T00095

THD – Output Level Characteristics (1)

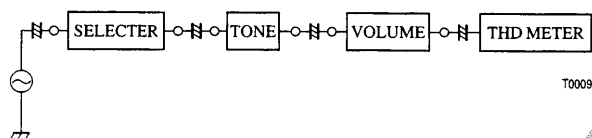
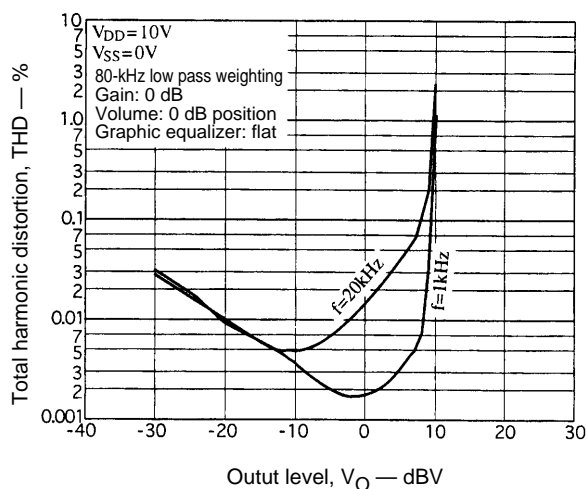

THD – Output Level Characteristics (2)

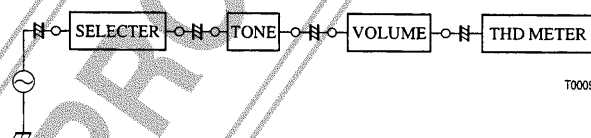
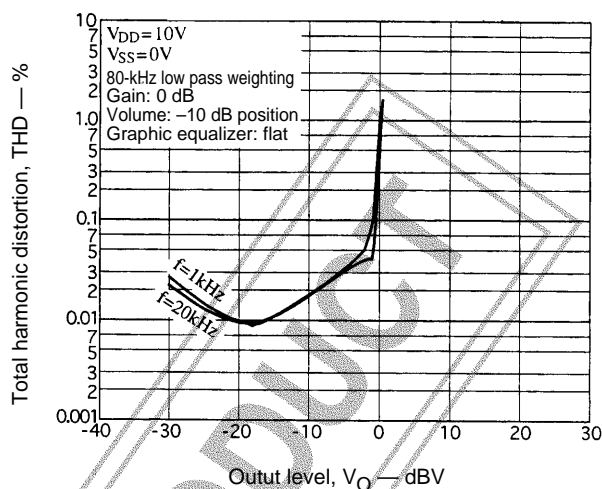

THD – Output Level Characteristics (3)

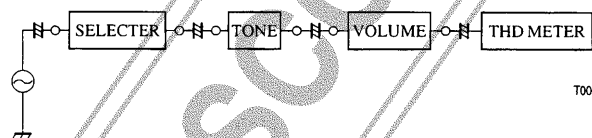
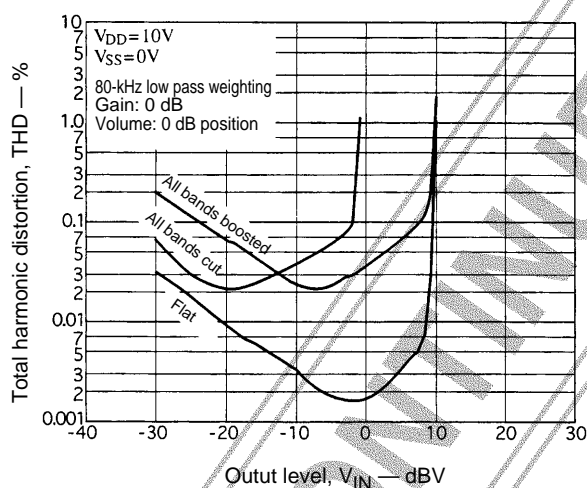

Usage Notes

- When the power is first applied, the internal analog switches are in indeterminate states. The chip therefore requires muting or other external measures until it has received the proper data.
- After power is first applied, applications must initialize this chip by sending the initial data (1) and (2) described below.
 - Initial data ... (1) Address 01000001
Data: (Set the volume to $-\infty$, set both D34 and D35 to 0, and set all other data to 0)
 - (2) Address 01000001
Data: (Set the volume to $-\infty$, set both D34 and D35 to 1, and set all other data to 0)
 After transferring that data, set the left and right channel initial settings before turning off the mute function.
- Provide grounding patterns or shielding for the lines to the CL, DI, and CE pins so as to prevent their high-frequency digital signals from interfering with the operation of nearby analog circuits.

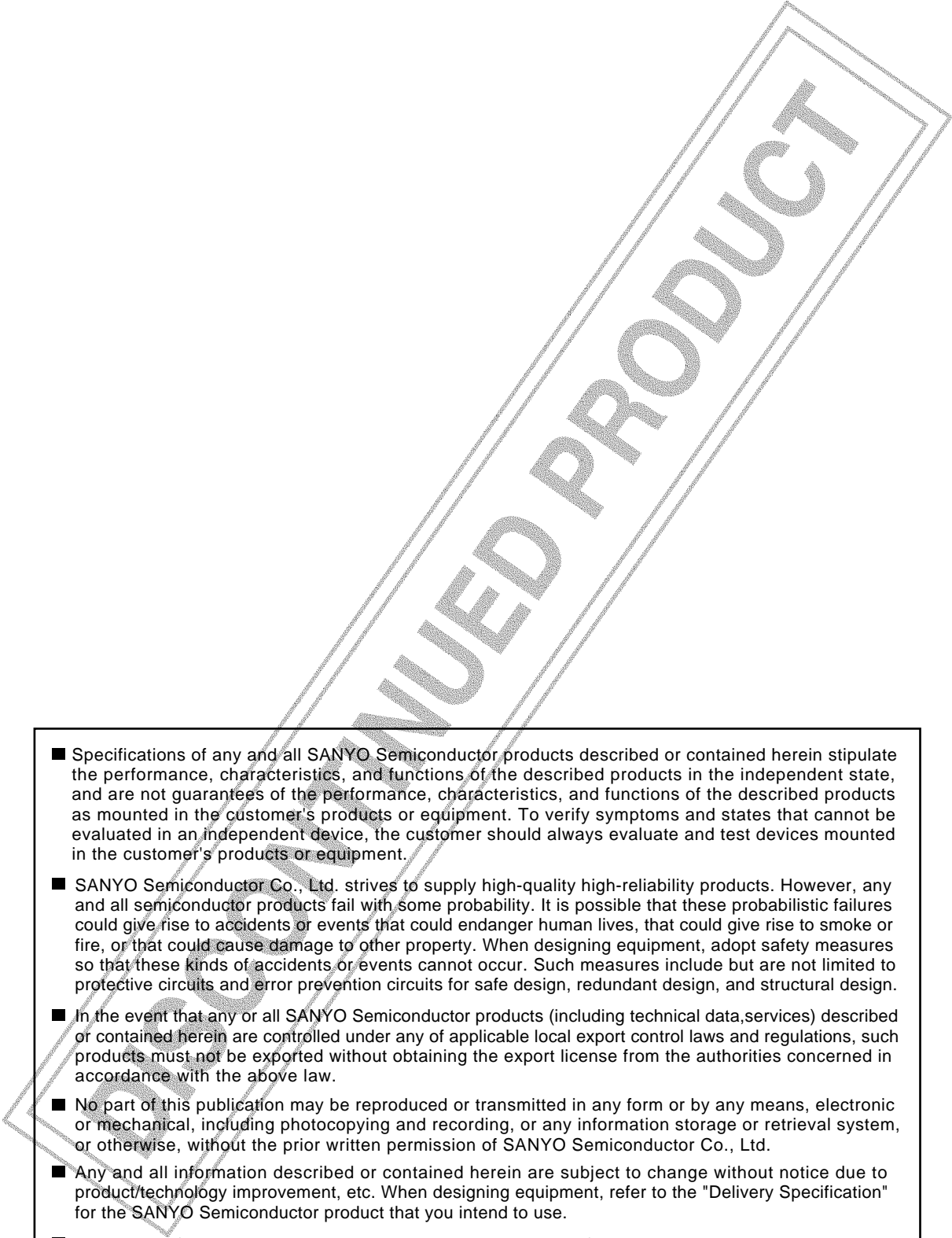
- 
- Specifications of any and all SANYO Semiconductor products described or contained herein stipulate the performance, characteristics, and functions of the described products in the independent state, and are not guarantees of the performance, characteristics, and functions of the described products as mounted in the customer's products or equipment. To verify symptoms and states that cannot be evaluated in an independent device, the customer should always evaluate and test devices mounted in the customer's products or equipment.
 - SANYO Semiconductor Co., Ltd. strives to supply high-quality high-reliability products. However, any and all semiconductor products fail with some probability. It is possible that these probabilistic failures could give rise to accidents or events that could endanger human lives, that could give rise to smoke or fire, or that could cause damage to other property. When designing equipment, adopt safety measures so that these kinds of accidents or events cannot occur. Such measures include but are not limited to protective circuits and error prevention circuits for safe design, redundant design, and structural design.
 - In the event that any or all SANYO Semiconductor products (including technical data, services) described or contained herein are controlled under any of applicable local export control laws and regulations, such products must not be exported without obtaining the export license from the authorities concerned in accordance with the above law.
 - No part of this publication may be reproduced or transmitted in any form or by any means, electronic or mechanical, including photocopying and recording, or any information storage or retrieval system, or otherwise, without the prior written permission of SANYO Semiconductor Co., Ltd.
 - Any and all information described or contained herein are subject to change without notice due to product/technology improvement, etc. When designing equipment, refer to the "Delivery Specification" for the SANYO Semiconductor product that you intend to use.
 - Information (including circuit diagrams and circuit parameters) herein is for example only; it is not guaranteed for volume production. SANYO Semiconductor believes information herein is accurate and reliable, but no guarantees are made or implied regarding its use or any infringements of intellectual property rights or other rights of third parties.

This catalog provides information as of May, 1998. Specifications and information herein are subject to change without notice.