

800MHz Band Receive Mixer

Description

The CXG1111EN is a mixer MMIC for the Japan CDMA cellular. This IC is designed using the Sony's GaAs J-FET process.

Features

- High conversion gain: $G_c = 13.0\text{dB}$ (Typ.)
- Low noise figure: $NF = 4.5\text{dB}$ (Typ.)
- Low distortion: $IIP3 = +2.5\text{dBm}$ (Typ.)
- Small package: 10-pin VSON

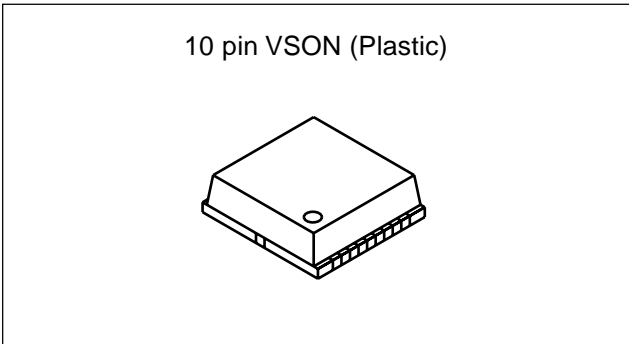

Applications

J-CDMA, PDC 800MHz and others

Structure

GaAs J-FET MMIC

Absolute Maximum Ratings ($T_a = 25^\circ\text{C}$)

- Supply voltage V_{DD} 4.5 V
- Input power P_{IN} +5 dBm
- Operating temperature T_{opr} -35 to $+85$ $^\circ\text{C}$
- Storage temperature T_{stg} -65 to $+150$ $^\circ\text{C}$

Recommended Operating Condition

Supply voltage V_{DD} 2.7 to 3.3 V

Pin Configuration

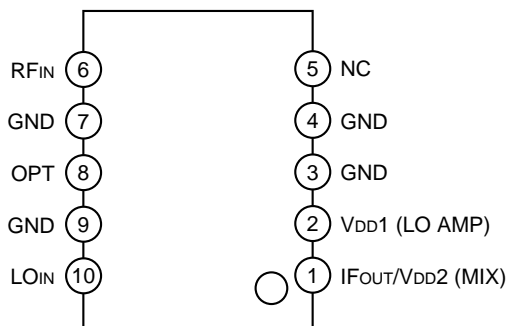

Block Diagram

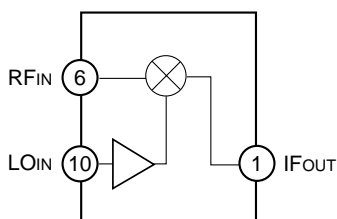

Note on handling

GaAs MMICs are ESD sensitive devices. Special handling precautions are required.

Sony reserves the right to change products and specifications without prior notice. This information does not convey any license by any implication or otherwise under any patents or other right. Application circuits shown, if any, are typical examples illustrating the operation of the devices. Sony cannot assume responsibility for any problems arising out of the use of these circuits.

Electrical Characteristics

Conditions: $V_{DD} = 2.7V$, $f_{RF} = 850MHz$, $f_{LO} = 740MHz$, $P_{LO} = -10dBm$

($T_a = 25^{\circ}C$)

Item	Symbol	Min.	Typ.	Max.	Unit	Condition
Current consumption	I_{DD}	—	7.5	10	mA	When no signal
Conversion gain	G_c	11.5	13	14.5	dB	When a small signal
Noise figure	NF	—	4.5	6	dB	
Input IP3	IIP3	0.5	2.5	—	dBm	*1
LO – RF leak level	PLK	—	-20	-17	dBm	—

*1 Conversion from the IM3 suppression ratio for two-wave input: $f_{RF} = 850MHz/850.9MHz$ and $P_{RF} = -25dBm$.

Recommended Evaluation Circuit

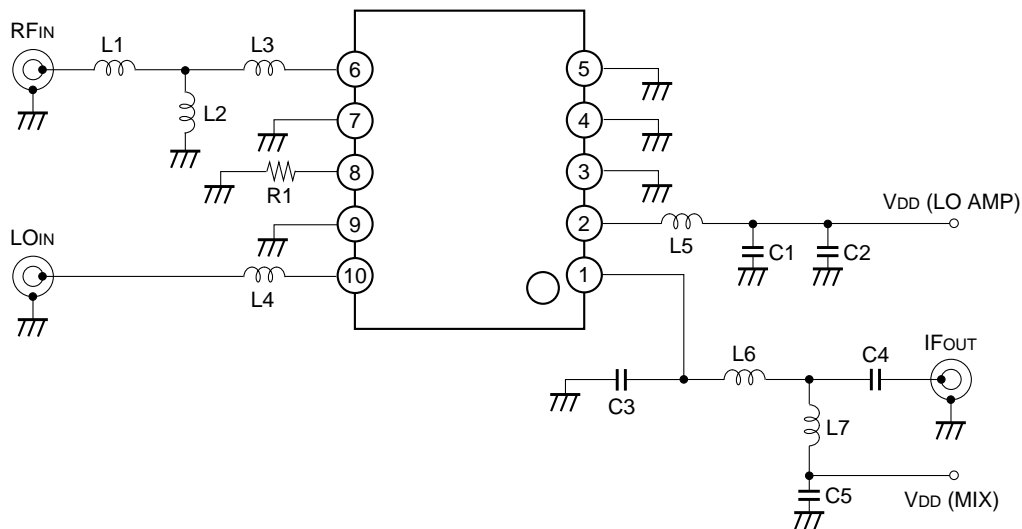

L1	18nH	L6	220nH	C4	1000pF
L2	22nH	L7	220nH	C5	1000pF
L3	27nH	C1	100pF	R1	27Ω
L4	33nH	C2	1000pF		
L5	33nH	C3	8pF		

Example of Representative Characteristics (Ta = 25°C)

Mixer Block

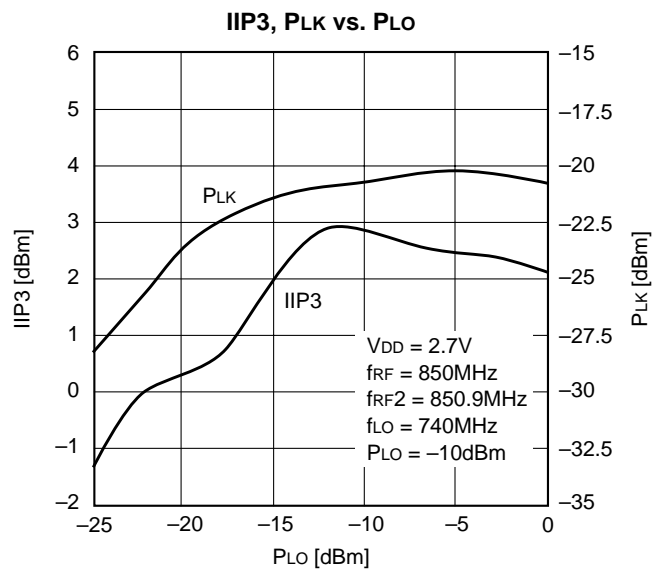
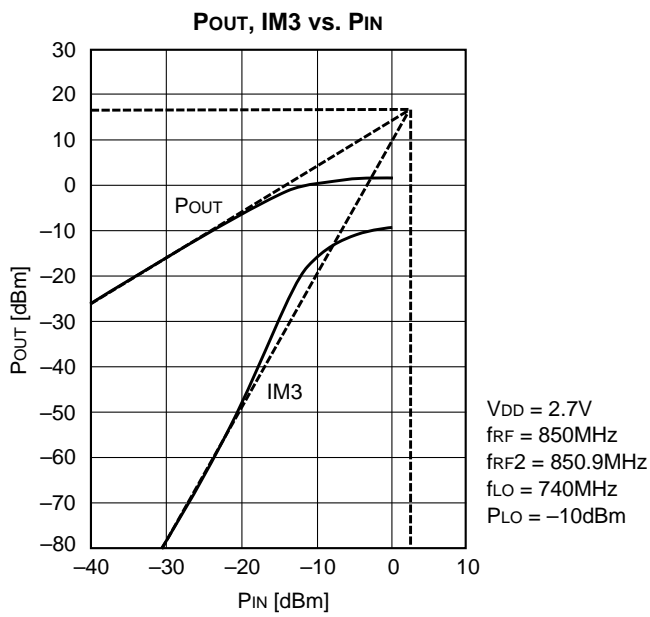
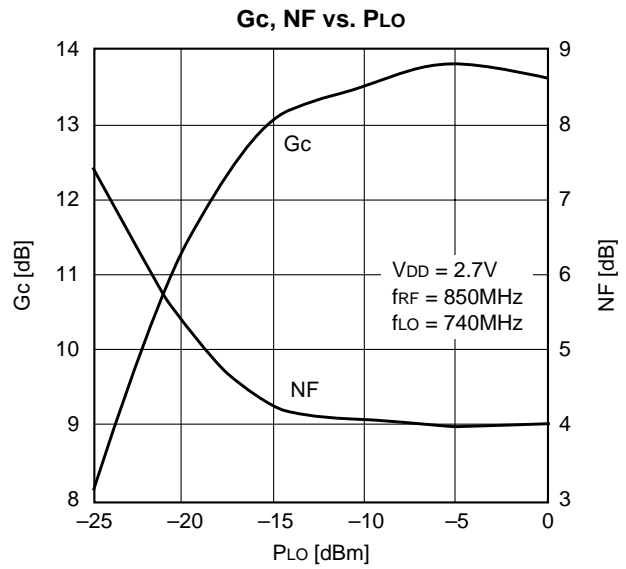
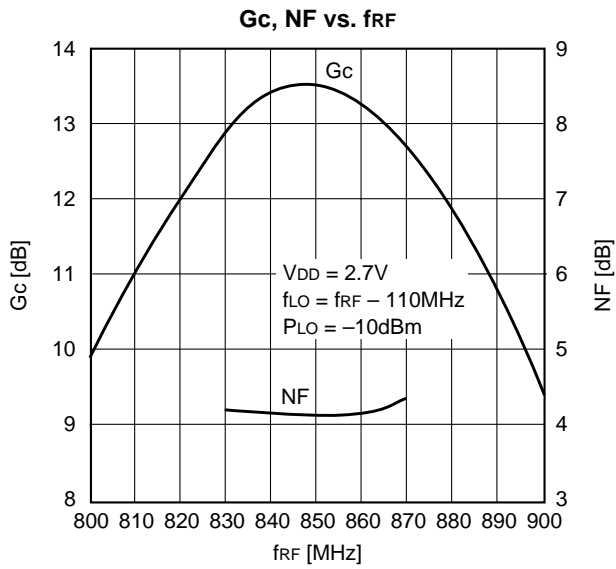

Example of Representative Characteristics for Option Resistance R1 Changed (Ta = 25°C)

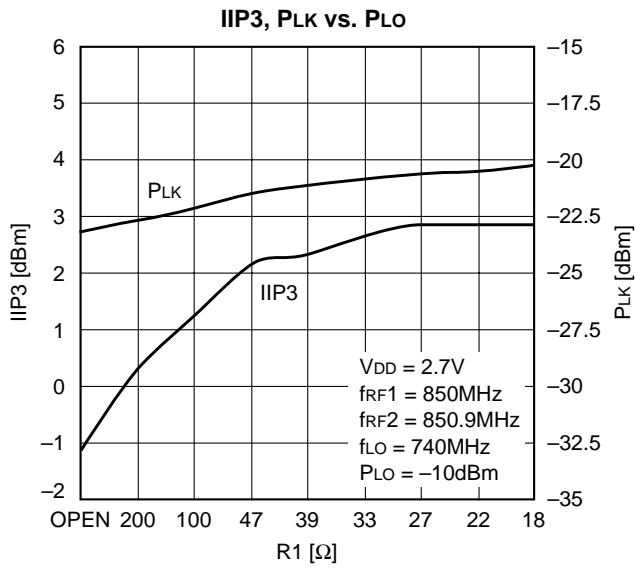
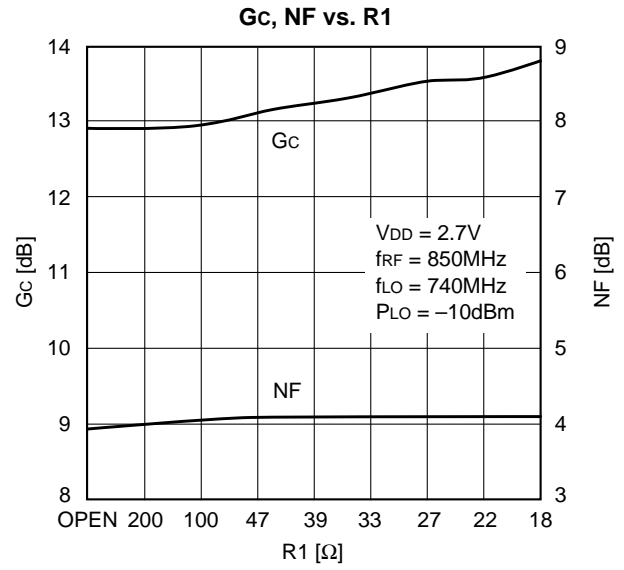
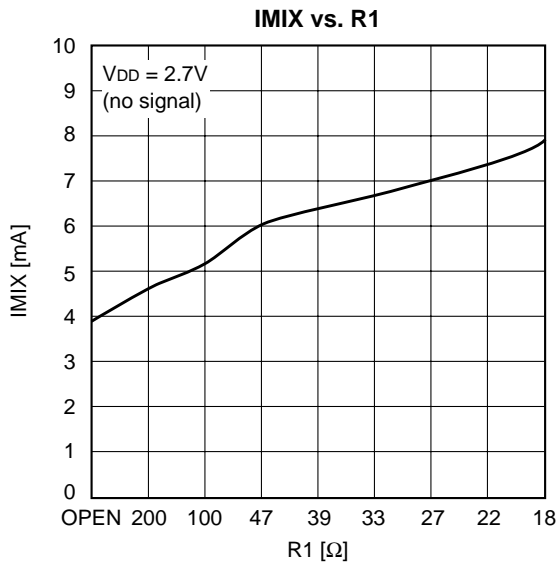

Recommended Evaluation Board

Front

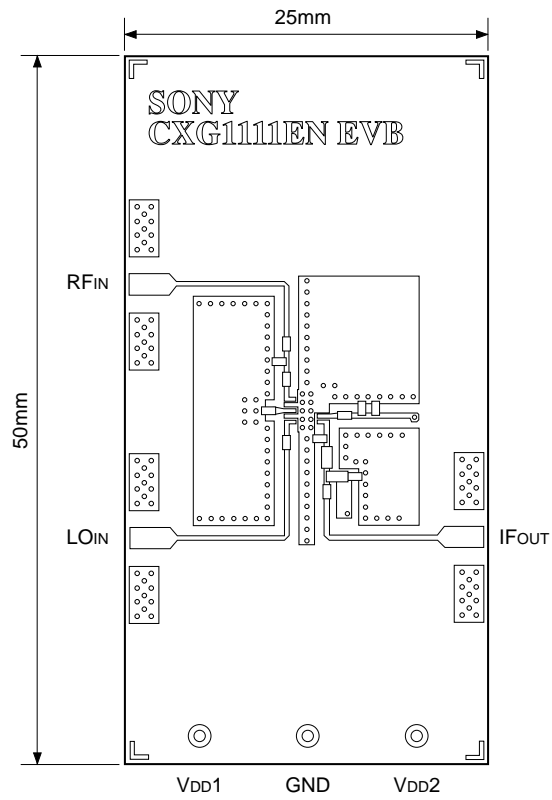

Glass fabric-base 4-layer epoxy board (thickness: 0.2mm × 2)
GND for the whole 2nd and 3rd layers

Enlarged Diagram of Center Part

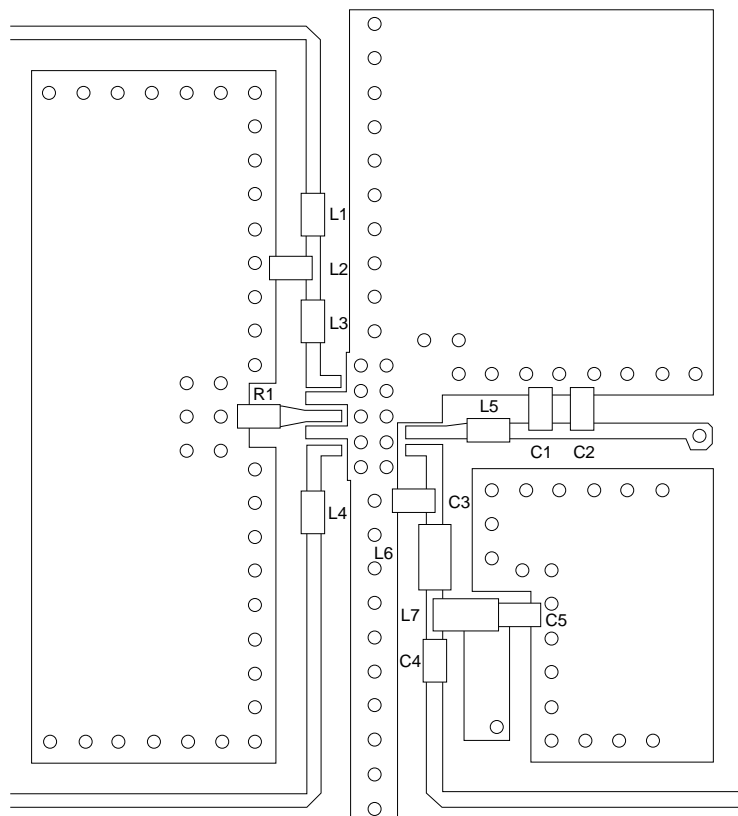

Package Outline

Unit: mm

10PIN VSON(PLASTIC)

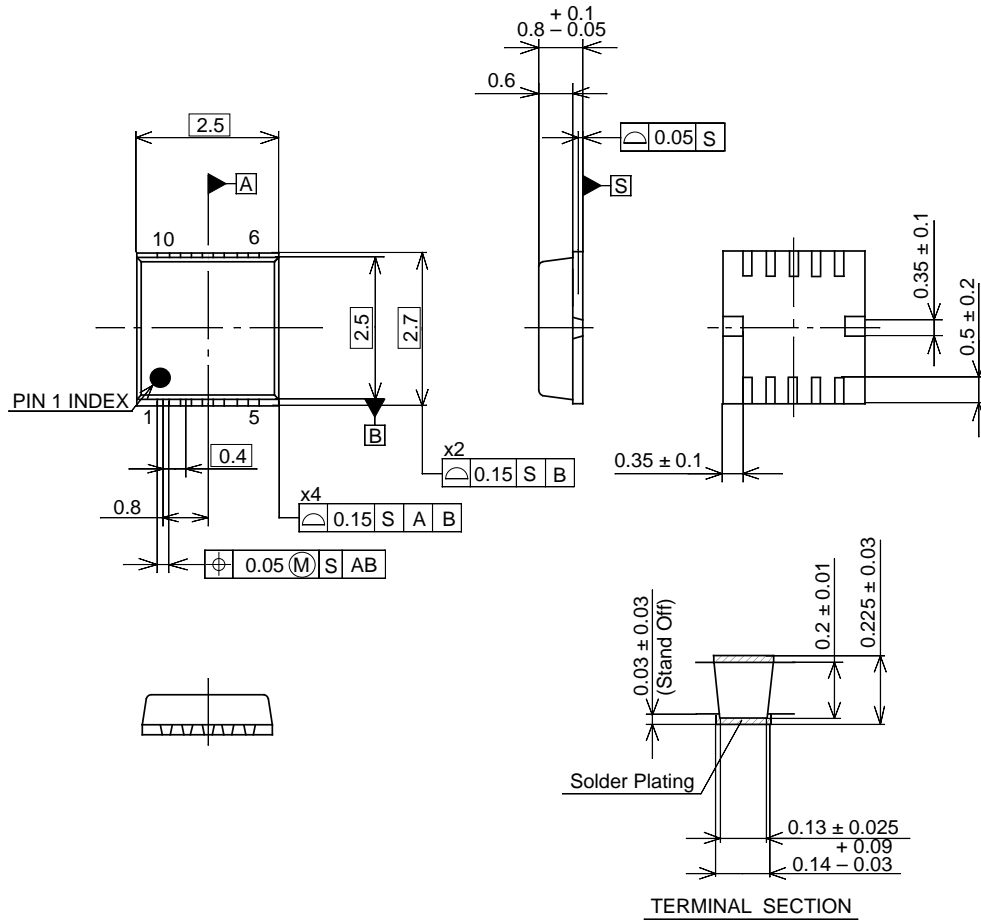

PACKAGE STRUCTURE

SONY CODE	VSON-10P-01
EIAJ CODE	—
JEDEC CODE	—

PACKAGE MATERIAL	EPOXY RESIN
LEAD TREATMENT	SOLDER PLATING
LEAD MATERIAL	COPPER ALLOY
PACKAGE MASS	0.013g