

# CDC587

## 3.3-V PHASE-LOCK LOOP CLOCK DRIVER WITH 3-STATE OUTPUTS

SCAS562B – DECEMBER 1996 – REVISED JULY 1998

- Low-Output Skew and Jitter for Clock Distribution and Synchronization
- Operates at 3.3-V  $V_{CC}$
- Distributes One Clock Input to 16 Outputs
- Four Select Inputs Configure Output Frequency
- Internal Loop Filter Eliminates the Need for External RC Network
- Dedicated External Feedback Output and Input for Phase Synchronization With the Clock Input
- Applications for Synchronous DRAM, High-Speed Microprocessors, and SSTL\_3 Applications
- LVTTTL- or SSTL\_3-Compatible Inputs and Outputs
- Distributed  $V_{CC}$  and Ground Pins Reduce Switching Noise
- Meets SSTL\_3 Class 1 and 2 Specifications
- Packaged in Plastic Small-Outline Package

### description

The CDC587 is a high-performance, low-skew, low-jitter, phase-lock loop (PLL) clock driver. It uses a PLL to precisely align, in both frequency and phase, the clock output signals to the clock input (CLKIN) signal. The CDC587 operates at 3.3-V  $V_{CC}$  and provides LVTTTL- or SSTL\_3-compatible inputs and outputs. The CDC587 operates at frequencies from 16.67 MHz up to 150 MHz, and is ideally suited for high-speed microprocessor and synchronous DRAM applications.

A dedicated feedback output (FBOUT) is used to synchronize the output clocks in frequency and phase to the CLKIN reference. Four banks of four outputs (1Yn, 2Yn, 3Yn, 4Yn) are configured to operate at specified ratios of the input frequency by four select (SELn) inputs. Selectable ratios of the input frequency are 1X, 2X, 3X, 1/2X, and 1/3X.

The output-enable ( $\overline{OE}$ ) input provides control for the Y output banks. When  $\overline{OE}$  is high, the outputs are in a high-impedance state. When  $\overline{OE}$  is low, the outputs switch in accordance with the select inputs. In addition, RESET provides a master reset for the CDC587 counter circuitry. This allows the outputs to be reset to a known state. TEST provides a bypass of the integrated PLL and divider circuitry. When TEST is high, the input clock bypasses the PLL and is buffered directly to the outputs.

DGG PACKAGE  
(TOP VIEW)

CLKIN	1	56	$V_{CC}$
VREF	2	55	GND
FBIN	3	54	$AV_{CC}$
$V_{CC}$	4	53	AGND
FBOUT	5	52	$AV_{CC}$
GND	6	51	AGND
$V_{CC}$	7	50	$V_{CC}$
1Y0	8	49	4Y0
1Y1	9	48	4Y1
GND	10	47	GND
$V_{CC}$	11	46	$V_{CC}$
1Y2	12	45	4Y2
1Y3	13	44	4Y3
GND	14	43	GND
$V_{CC}$	15	42	$V_{CC}$
2Y0	16	41	3Y0
2Y1	17	40	3Y1
GND	18	39	GND
$V_{CC}$	19	38	$V_{CC}$
2Y2	20	37	3Y2
2Y3	21	36	3Y3
GND	22	35	GND
$V_{CC}$	23	34	$V_{CC}$
GND	24	33	GND
SEL0	25	32	RESET
SEL1	26	31	TEST
SEL2	27	30	$\overline{OE}$
SEL3	28	29	GND

PRODUCT PREVIEW

**CDC587**  
**3.3-V PHASE-LOCK LOOP CLOCK DRIVER**  
**WITH 3-STATE OUTPUTS**

SCAS582B – DECEMBER 1995 – REVISED JULY 1996

**description (continued)**

The loop filter components of the PLL are integrated on the CDC587. This reduces the need for external loop components and provides an easily implemented PLL circuit. FBOU<sub>T</sub> should be connected to the feedback input (FBIN) for normal operation of the PLL.

The voltage-controlled oscillator (VCO) of the integrated PLL has an operating range of 100 MHz to 300 MHz. The VCO is designed to operate at two to twelve times the CLKIN frequency. This allows the CDC587 to achieve output frequencies from 16.67 MHz to 150 MHz with a duty cycle of 50% ±5% ensured.

Independent analog V<sub>CC</sub> (AV<sub>CC</sub>) and ground (AGND) connections are provided for VCO stability.

CLKIN and FBIN can be configured to switch at SSTL\_3 input levels by connecting V<sub>REF</sub> to a nominal reference voltage of 1.5 V. If V<sub>REF</sub> is strapped to GND, CLKIN and FBIN switch at normal TTL input thresholds.

Because the CDC587 is based on PLL technology, it requires a stabilization time to achieve phase lock of the FBIN to the reference input clock. This stabilization time is required following power up and application of a fixed-frequency, fixed-phase signal at CLKIN. In addition, a stabilization time may be required following changes to the SEL<sub>n</sub> inputs, TEST inputs, or a change in frequency of the CLKIN signal.

**FUNCTION TABLE**  
**(PLL enabled)**

OE	INPUTS					OUTPUTS					
	SEL3	SEL2	SEL1	SEL0	F <sub>INmin</sub>	F <sub>INmax</sub>	FBOU <sub>T</sub>	1Y(0:3)	2Y(0:3)	3Y(0:3)	4Y(0:3)
H	X	X	X	X	Note 1	Note 1	Note 1	Hi Z	Hi Z	Hi Z	Hi Z
L	L	L	L	L	50 MHz	150 MHz	VCO/2	1X	1X	1X	1X
L	L	L	L	H	25 MHz	75 MHz	VCO/4	1X	1X	1X	2X
L	L	L	H	L	25 MHz	75 MHz	VCO/4	1X	1X	2X	2X
L	L	L	H	H	25 MHz	75 MHz	VCO/4	1X	2X	2X	2X
L	L	H	L	L	25 MHz	75 MHz	VCO/4	2X	2X	2X	2X
L	L	H	L	H	16.67 MHz	50 MHz	VCO/6	1X	1X	1X	3X
L	L	H	H	L	16.67 MHz	50 MHz	VCO/6	1X	1X	3X	3X
L	L	H	H	H	16.67 MHz	50 MHz	VCO/6	1X	3X	3X	3X
L	H	L	L	L	16.67 MHz	50 MHz	VCO/6	3X	3X	3X	3X
L	H	L	L	H	50 MHz	150 MHz	VCO/2	1X	1X	1X	1/2X
L	H	L	H	L	50 MHz	150 MHz	VCO/2	1X	1X	1/2X	1/2X
L	H	L	H	H	50 MHz	150 MHz	VCO/2	1X	1/2X	1/2X	1/2X
L	H	H	L	L	50 MHz	150 MHz	VCO/2	1/2X	1/2X	1/2X	1/2X
L	H	H	L	H	50 MHz	150 MHz	VCO/2	1X	1X	1X	1/3X
L	H	H	H	L	50 MHz	150 MHz	VCO/2	1X	1X	1/3X	1/3X
L	H	H	H	H	50 MHz	150 MHz	VCO/2	1X	1/3X	1/3X	1/3X

NOTE 1: Minimum and maximum input frequency and FBOU<sub>T</sub> frequency depend on the configuration of the SEL<sub>n</sub> inputs.

PRODUCT PREVIEW



**CDC587**  
**3.3-V PHASE-LOCK LOOP CLOCK DRIVER**  
**WITH 3-STATE OUTPUTS**  
SCAS562B - DECEMBER 1995 - REVISED JULY 1996

functional block diagram

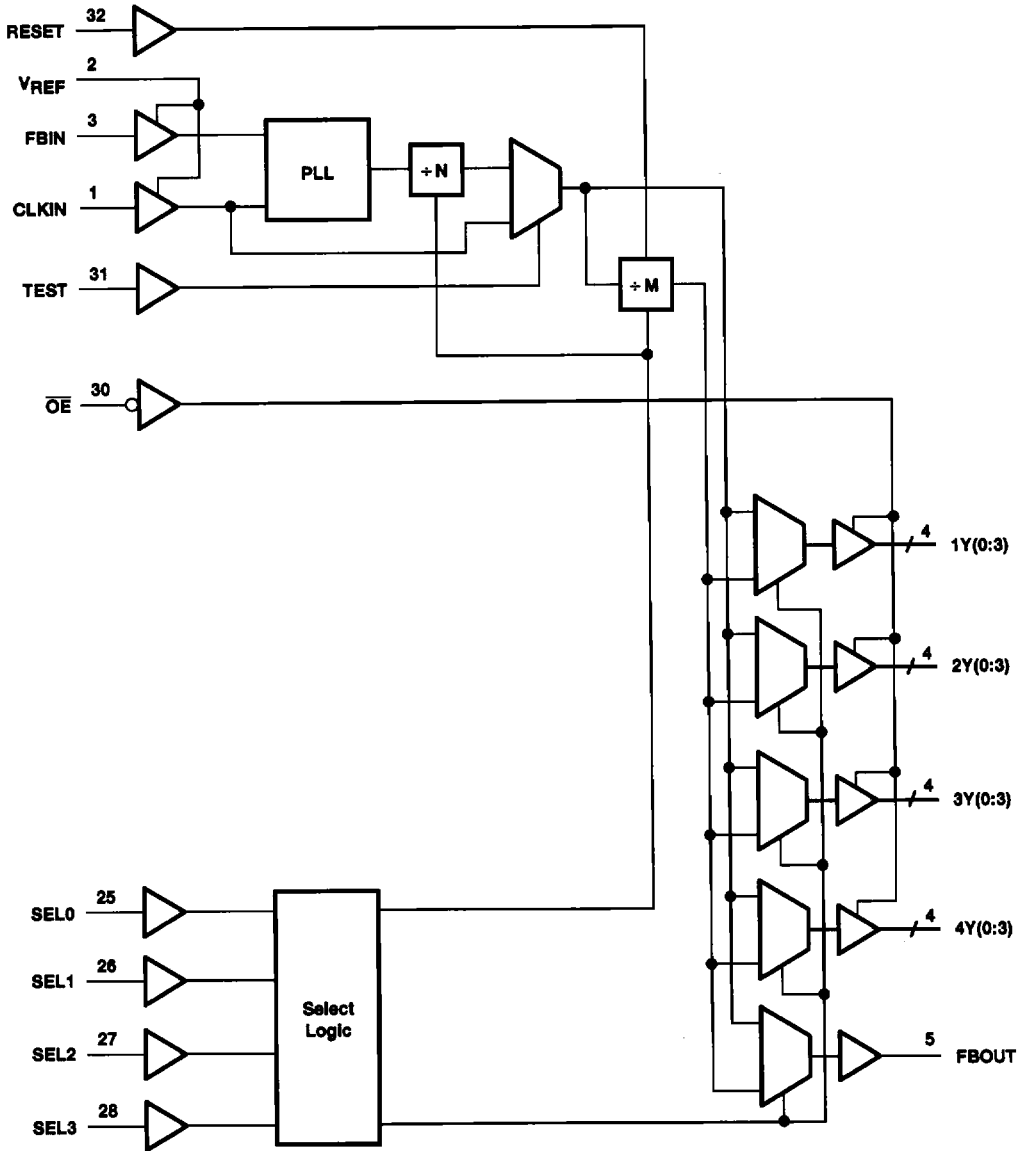

**PRODUCT PREVIEW**

**CDC587**  
**3.3-V PHASE-LOCK LOOP CLOCK DRIVER**  
**WITH 3-STATE OUTPUTS**

SCAS562B – DECEMBER 1995 – REVISED JULY 1996

**Terminal Functions**

TERMINAL		I/O	DESCRIPTION
NAME	NO.		
CLKIN	1	I	Clock input. CLKIN provides the clock signal to be distributed by the CDC587 clock-driver circuit. CLKIN is used to provide the reference signal to the integrated PLL that generates the clock output signals. CLKIN must have a fixed frequency and fixed phase for the PLL to obtain phase lock. Once the circuit is powered up and a valid CLKIN signal is applied, a stabilization time is required for the PLL to phase-lock the feedback signal to its reference signal.
FBIN	3	I	Feedback input. FBIN provides the feedback signal to the internal PLL. FBIN should be wired to FBOUT. The integrated PLL adjusts the output clocks to obtain zero phase delay between FBIN and CLKIN.
VREF	2	I	Voltage reference. VREF is the reference voltage required for SSTL operation. A nominal voltage of 1.5 V should be applied when SSTL operation of CLKIN and FBIN is required. If VREF is strapped to GND, CLKIN and FBIN operate at TTL switching levels.
$\overline{OE}$	30	I	Output enable. $\overline{OE}$ is the output enable for all of the Y outputs. When $\overline{OE}$ is low, all Y outputs are enabled. When $\overline{OE}$ is high, all Y outputs are in the high-impedance state. FBOUT is not disabled by $\overline{OE}$ , therefore the PLL is not disrupted when placing the Y outputs into the high-impedance state.
TEST	31	I	Test input. TEST is used to bypass the PLL circuitry for factory testing of the device. When TEST is low, all outputs operate using the PLL circuitry. When TEST is high, the device is placed in a test mode that bypasses the PLL circuitry.
RESET	32	I	Reset input. RESET is used to reset the counter circuit that divides the VCO output frequency. Y outputs configured as fractional frequencies of the input signal may be reset to a known state. RESET is a negative-edge-triggered signal. When a high-to-low edge occurs at RESET, the counter that divides the VCO output signal is asynchronously cleared to a low level.
SEL(0:3)	28–25	I	Select input. SEL(0:3) configures the frequency of the Y outputs in banks of four.
1Y(0:3) 2Y(0:3) 3Y(0:3) 4Y(0:3)	8, 9, 12, 13 16, 17, 20, 21 36, 37, 40, 41 44, 45, 48, 49	O	Clock outputs. These outputs are configured by SEL(0:3) to transmit a multiple or fraction of the input frequency. The relationship between the CLKIN frequency and the output frequency is dependent on the select inputs. Due to normal operation of the PLL, the duty cycle of the Y output signals is nominally 50%, independent of the duty cycle of CLKIN.
FBOUT	5	O	Feedback output. FBOUT is synchronized in phase and frequency to the input clock. FBOUT is not a 3-state output and is not disabled when $\overline{OE}$ is asserted low. A stabilization time is required on power up and the application of a fixed frequency, fixed-phase signal at CLKIN. In addition, the stabilization time may be required when changes occur to the input signal or the states of the SEL(0:3) control inputs.

**PRODUCT PREVIEW**

**absolute maximum ratings over operating free-air temperature range (unless otherwise noted)†**

Supply voltage range, $V_{CC}$ .....	-0.5 V to 4.6 V
Input voltage range, $V_I$ (see Note 2) .....	-0.5 V to 7 V
Voltage range applied to any output in the high state or power-off state, $V_O$ (see Note 2) .....	-0.5 V to $V_{CC} + 0.5$ V
Current into any output in the low state, $I_O$ .....	48 mA
Input clamp current, $I_{IK}$ ( $V_I < 0$ ) .....	-20 mA
Output clamp current, $I_{OK}$ ( $V_O < 0$ ) .....	-50 mA
Maximum power dissipation at $T_A = 55^\circ\text{C}$ (in still air) (see Note 3) .....	1.2 W
Storage temperature range, $T_{stg}$ .....	-65°C to 150°C

† Stresses beyond those listed under "absolute maximum ratings" may cause permanent damage to the device. These are stress ratings only, and functional operation of the device at these or any other conditions beyond those indicated under "recommended operating conditions" is not implied. Exposure to absolute-maximum-rated conditions for extended periods may affect device reliability.

- NOTES: 2. The input and output negative-voltage ratings may be exceeded if the input and output clamp-current ratings are observed.  
 3. The maximum package power dissipation is calculated using a junction temperature of 150°C and a board trace length of 750 mils. For more information, refer to the *Package Thermal Considerations* application note in the *ABT Advanced BiCMOS Technology Data Book*, literature number SCBD002.



**CDC587**  
**3.3-V PHASE-LOCK LOOP CLOCK DRIVER**  
**WITH 3-STATE OUTPUTS**

SCAS562B – DECEMBER 1995 – REVISED JULY 1996

**recommended operating conditions (see Note 4)**

		MIN	NOM	MAX	UNIT
V <sub>CC</sub>	Supply voltage	3		3.6	V
V <sub>REF</sub>	SSTL reference voltage	1.3	1.5	1.7	V
V <sub>I</sub>	Input voltage	0		5.5	V
V <sub>IH</sub>	High-level input voltage	CLK, FBIN	V <sub>REF</sub> +100 mV		V
		CLK, FBIN (V <sub>REF</sub> = GND)	2		
		Other inputs	2		
V <sub>IL</sub>	Low-level input voltage	CLK, FBIN	V <sub>REF</sub> -100 mV		V
		CLK, FBIN (V <sub>REF</sub> = GND)	0.8		
		Other inputs	0.8		
I <sub>OH</sub>	High-level output current			-20	mA
I <sub>OL</sub>	Low-level output current			20	mA
T <sub>A</sub>	Operating free-air temperature	0		70	°C

NOTE 4: Unused inputs must be held high or low to prevent them from floating.

**electrical characteristics over recommended operating free-air temperature range (unless otherwise noted)**

PARAMETER	TEST CONDITIONS		MIN	TYPT	MAX	UNIT
V <sub>IK</sub>	V <sub>CC</sub> = 3 V,	I <sub>I</sub> = -18 mA			-1.2	V
V <sub>OH</sub>	V <sub>CC</sub> = MIN to MAX†,	I <sub>OH</sub> = -100 µA	V <sub>CC</sub> -0.2		V	
	V <sub>CC</sub> = 3 V	I <sub>OH</sub> = -16 mA	2.2			
		I <sub>OH</sub> = -20 mA	2.1			
V <sub>OL</sub>	V <sub>CC</sub> = 3 V	I <sub>OL</sub> = 100 µA	0.2		V	
		I <sub>OL</sub> = 16 mA	0.5			
		I <sub>OL</sub> = 20 mA	0.5			
I <sub>I</sub>	V <sub>CC</sub> = 0 or MAX†,	V <sub>I</sub> = 3.6 V, V <sub>REF</sub> = GND	±10		µA	
	V <sub>CC</sub> = 3.6 V	V <sub>I</sub> = V <sub>CC</sub> or GND, V <sub>REF</sub> = GND	±1			
		V <sub>I</sub> = 2.1 V or 0.9 V, V <sub>REF</sub> = 1.5	±1			
I <sub>OZH</sub>	V <sub>CC</sub> = 3.6 V,	V <sub>O</sub> = 3 V			10	µA
I <sub>OZL</sub>	V <sub>CC</sub> = 3.6 V,	V <sub>O</sub> = 0			-10	µA
I <sub>CC</sub>	V <sub>CC</sub> = 3.6 V, I <sub>O</sub> = 0	V <sub>I</sub> = V <sub>CC</sub> or GND, V <sub>REF</sub> = GND			1	mA
		V <sub>I</sub> = 2.1 V or 0.9 V, V <sub>REF</sub> = 1.5 V			6	
C <sub>i</sub>	V <sub>I</sub> = V <sub>CC</sub> or GND, V <sub>REF</sub> = GND			3	pF	
	V <sub>I</sub> = 2.1 V or 0.9 V, V <sub>REF</sub> = 1.5 V			3		
C <sub>o</sub>	V <sub>O</sub> = 3 V or 0, V <sub>REF</sub> = GND			6	pF	
	V <sub>O</sub> = 2.1 V or 0.9 V, V <sub>REF</sub> = 1.5 V			6		

† All typical values are at V<sub>CC</sub> = 3.3 V, T<sub>A</sub> = 25°C.

‡ For conditions shown as MIN or MAX, use the appropriate value specified under recommended operating conditions.

**PRODUCT PREVIEW**



**CDC587**  
**3.3-V PHASE-LOCK LOOP CLOCK DRIVER**  
**WITH 3-STATE OUTPUTS**

SCAS582B – DECEMBER 1995 – REVISED JULY 1996

timing requirements over recommended ranges of supply voltage and operating free-air temperature (see Note 5)

		MIN	MAX	UNIT
f <sub>clock</sub>	Input clock frequency	VCO is operating at six times the CLKIN frequency		MHz
		VCO is operating at four times the CLKIN frequency		
		VCO is operating at two times the CLKIN frequency		
Input clock duty cycle		40%	60%	
Stabilization time†	After SELn			5
	After power up and CLKIN			5

† Time required for the integrated PLL circuit to obtain phase lock of its feedback signal to its reference signal. In order for phase lock to be obtained, a fixed-frequency, fixed-phase reference signal must be present at CLKIN. Until phase lock is obtained, the specifications for propagation delay and skew parameters given in the switching characteristics table are not applicable.

NOTE 5: Preliminary specifications based on SPICE analysis

switching characteristics over recommended ranges of supply voltage and operating free-air temperature, C<sub>L</sub> = 30 pF (see Note 6 and Figure 1)

PARAMETER	FROM (INPUT)	TO (OUTPUT)	MIN	TYP	MAX	UNIT
f <sub>max</sub>			150			MHz
t <sub>phase error</sub>	CLKIN↑	FBIN↑	-300		+300	ps
t <sub>sk(o)</sub> same frequency		Y		250		ps
t <sub>sk(o)</sub> different frequency			500			
Jitter (peak to peak)	CLKIN↑	Y↑	-75		+75	ps
Duty cycle		Y	45%		55%	
t <sub>r</sub>						ns
t <sub>f</sub>						ns

NOTE 6: The specifications for parameters in this table are applicable only after any appropriate stabilization time has elapsed.

switching characteristics over recommended ranges of supply voltage and operating free-air temperature, V<sub>REF</sub> = V<sub>TT</sub> = V<sub>CC</sub> × 0.45, C<sub>L</sub> = 30 pF (see Note 6 and Figure 2)

PARAMETER	FROM (INPUT)	TO (OUTPUT)	MIN	TYP	MAX	UNIT
f <sub>max</sub>			150			MHz
t <sub>phase error</sub>	CLKIN↑	FBIN↑	-300		+300	ps
t <sub>sk(o)</sub> same frequency		Y		250		ps
t <sub>sk(o)</sub> different frequency			500			
Jitter (peak to peak)	CLKIN↑	Y↑	-75		+75	ps
Duty cycle		Y	45%		55%	
t <sub>r</sub>						ns
t <sub>f</sub>						ns

NOTE 6: The specifications for parameters in this table are applicable only after any appropriate stabilization time has elapsed.

PRODUCT PREVIEW



PARAMETER MEASUREMENT INFORMATION

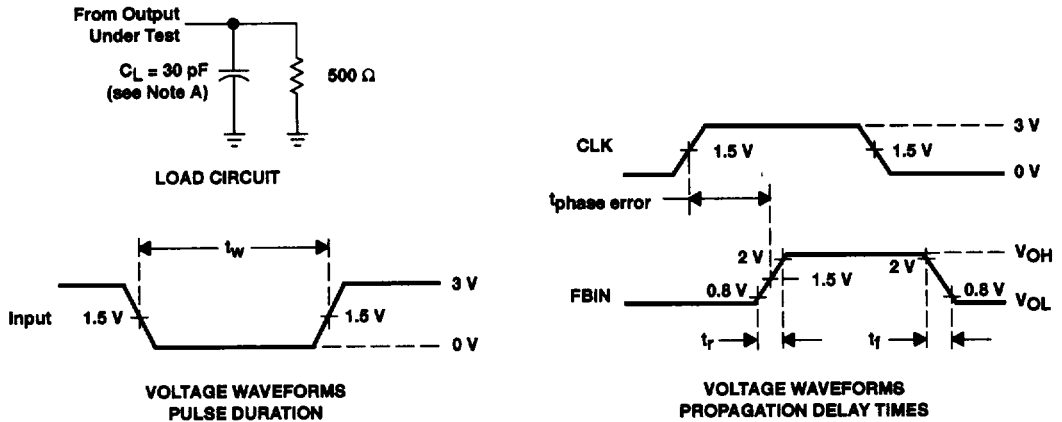

- NOTES: A.  $C_L$  includes probe and jig capacitance.  
 B. All Input pulses are supplied by generators having the following characteristics:  $PRR \leq 150$  MHz,  $Z_O = 50 \Omega$ ,  $t_r \leq 2.5$  ns,  $t_f \leq 2.5$  ns.  
 C. The outputs are measured one at a time with one transition per measurement.

Figure 1. Load Circuit and Voltage Waveforms for LVTTL

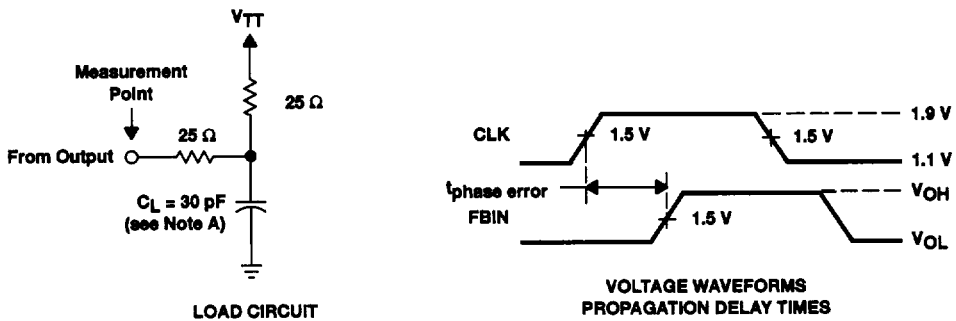

- NOTES: A.  $C_L$  includes probe and jig capacitance.  
 B. All input pulses are supplied by generators having the following characteristics:  $PRR \leq 150$  MHz,  $Z_O = 50 \Omega$ ,  $t_r \leq 2.5$  ns,  $t_f \leq 2.5$  ns.  
 C. The outputs are measured one at a time with one transition per measurement.  
 D.  $V_{TT} = V_{REF} = V_{CC} \times 0.45$

Figure 2. Load Circuit and Voltage Waveforms for SSTL\_3

PRODUCT PREVIEW