



AMERICAN MICROSYSTEMS, INC.

WavePlex™ Wireless Products

SX051 IF Transceiver IC

January, 1997

FEATURE SHEET

General Description

The SX051 Intermediate Frequency (IF) Transceiver is designed to compliment WavePlex baseband spectrum products. It will minimize the parts count for a complete spread spectrum radio leaving only the RF front-end to be added as discrete components.

The SX051 is a complete IF transceiver system that simplifies half duplex radio system design. There is a single input/output to the RF front-end and separate IQ inputs and outputs for baseband interface.

This IC is unique in providing the IF mixing and amplifying functions with a CMOS process. AMI's current 0.6 micron process is used to provide the gain and frequency response characteristics needed for a monolithic IF subsystem. Designed to support the need for low power portable operation, the process allows supply voltages in the range from 3 to 5 volts.

Yielding a very generic frequency plan fitting many radio architectures, the SX051 features twin synthesizers onboard which allow designers to choose the input frequency to the IC and the IF frequency.

In response to designer surveys, the SX051 offers despreading at the IF frequency resulting in simpler hardware implementation.

Features

- All CMOS design
- 3 volt and 5 volt operation
- Input frequencies of 350MHz, 280MHz, 250MHz, 200MHz, 180MHz and 140MHz
- Code despreading at IF frequency
- IF frequencies of 70MHz, 60MHz, 30MHz, 21.4MHz, 10.7MHz and 6.5MHz
- Two programmable frequency synthesizers
- Adjustable gain AGC amplifier
- RSSI output
- Estimated power dissipation of ~50mA RCV / 40mA (transmit) at 3 volts
- TQFP package (48 lead)
- Wideband spread signal capability
- Provides narrowband IF operation for FM voice or data radios
- Can function as a low-power, single-chip radio below 350MHz

BLOCK DIAGRAM

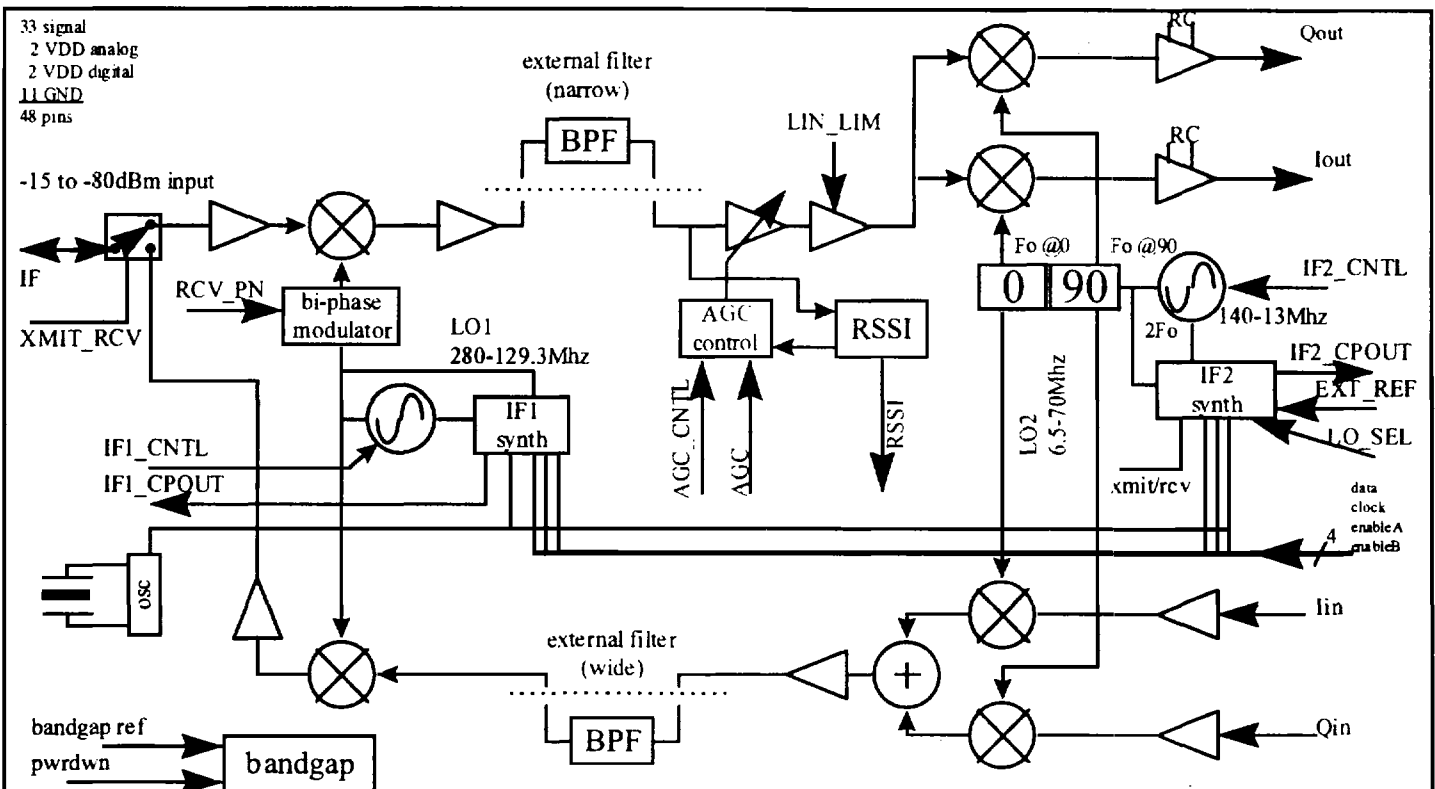

January, 1997

FEATURE SHEET

SIMPLE RADIO IMPLEMENTATION

As shown in the following diagram, a simple radio implementation using the SX051 would consist of an RF front-end, a controller and a modulator/demodulator function.

The RF section would consist of discrete or monolithic devices that filter, amplify and translate the desired frequency to the frequency range required at the IF level of the SX051.

The SX051 also filters, amplifies and translates the desired frequency component down to the baseband

level. At this point, the information is contained as complex I and Q components.

The mod/demod section is a collection of discrete and/or monolithic components used to recover the data and clock from the received IQ string. The transmit section converts the digital information from the controller and encodes it into a complex IQ modulation form that is passed to the SX051.

The controller is any 8/16 bit microcontroller that coordinates transceiver operation and executes a protocol program controlling the radio data channel.

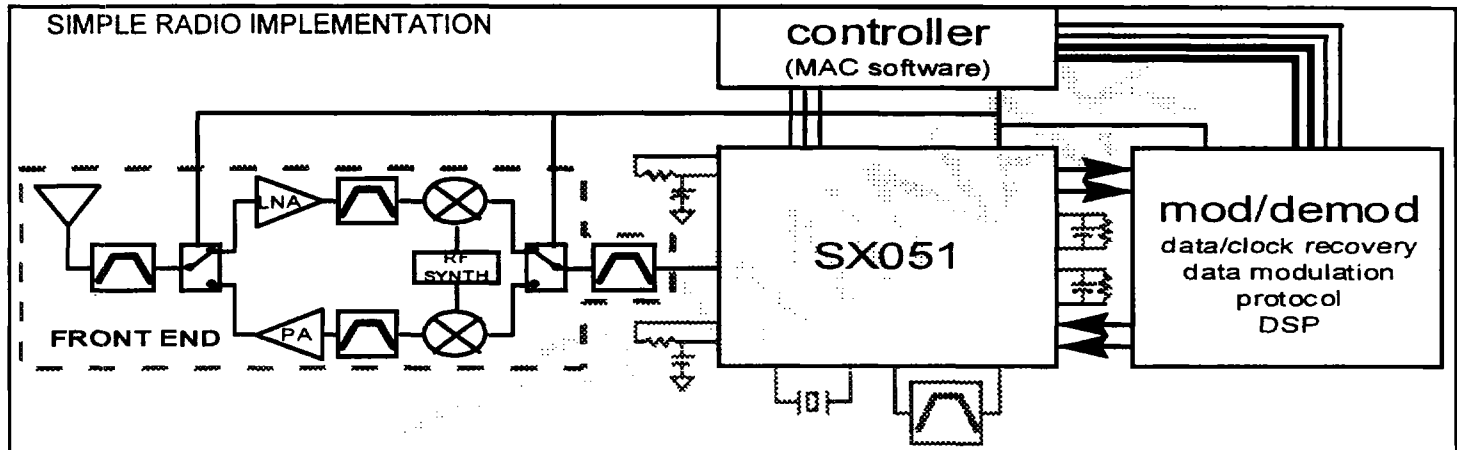

SPREAD SPECTRUM RADIO IMPLEMENTATION

The following diagram shows an example of a spread spectrum transceiver (SX043) using the SX051 base-band processor.

The receiver front-end is used to amplify, filter and translate the signal in the radio channel (2.4GHz or 900MHz) to the input range of the SX051 (350MHz to 140MHz).

The SX051 also amplifies, filters and translates the receive signal as well as despreads the incoming signal at the IF frequency. In transmit mode there are a few options to generate the spread signal. The simplest way is to spread the data signal in the SX043 and directly feed

the SX051 with the complex IQ signals bypassing the mod/demod block. The transmit data can also be sourced from the SX043 unspread and spread in the mod/demod chip. Spreading can also occur at the first RF mix. The mod/demod block can provide baud shaping of the IQ transmit data using DSP methods.

The SX043 provides the code tracking control using the RSSI output from the SX051. In receive mode, it provides the PN code sequence to external despreading hardware to decode the data. In the transmit mode, spreading can occur within the SX043 or it can provide the PN code for external data spreading.

