

1. General description

H18GAD32S is a CMOS(0.18 μ m, 1-poly, 3-metal) 10-bit successive –approximation ADC(analog-to- digital converter) which has high speed, low power consumption. The ADC has multiplexed eight input channels. The serial output is configured to interface with standard shift registers. The differential analog voltage input allows for common-mode rejection or offset of the analog zero input voltage value. The voltage reference input can be adjusted to allow encoding any smaller analog voltage span to the full 8bits of resolution

2. Features

- Power supply : 1.8v
- Resolution: 8 bits
- Signal-to-noise ratio(SNR) : 54dB
- Eight channel
- Conversion speed : 2usec (@ 8Mhz)
- Main clock : 8 MHz
- Process: 0.18 μ m CMOS generic Process (1-poly, 3-metal)
- Analog input range : 0 ~ 1.8V
- Minimum drawing Grid : 0.005 μ m
- Cell Size : 900 μ m x 800 μ m(with guard ring)

3. Block diagram with recommended application circuit

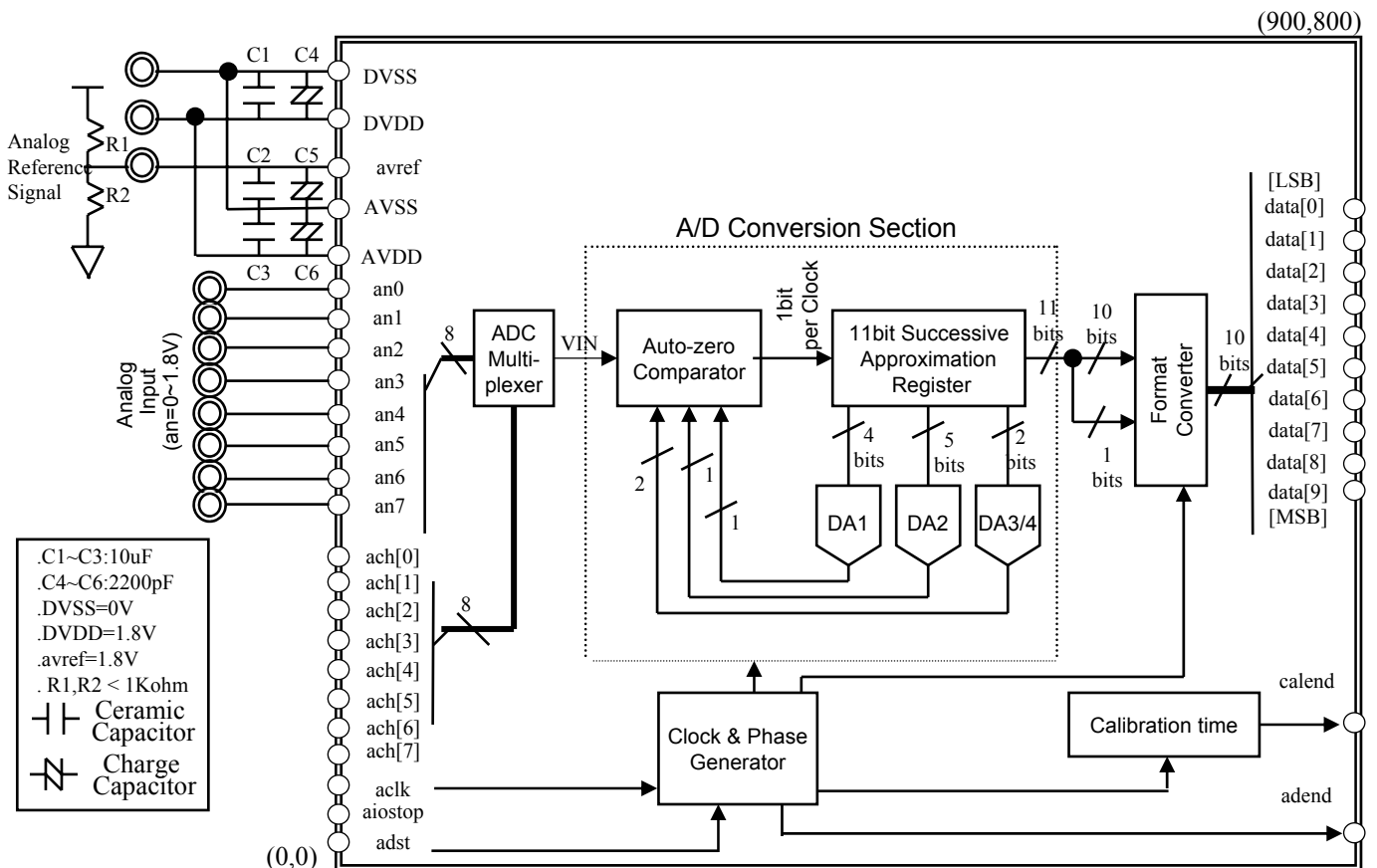

4. Pin Descriptions

Name	Type	Description
avref	Input	Analog Reference
AVSS	Ground	Analog Ground
AVDD	Power	Analog Power
an0	Input	Analog input0
an1	Input	Analog input1
an2	Input	Analog input2
an3	Input	Analog input3
an4	Input	Analog input4
an5	Input	Analog input5
an6	Input	Analog input6
an7	Input	Analog input7
ach[7:0]	Input	Select Channel [7:0]
aclk	Input	Clock
aiostop	Input	Power save
adst	Input	Conversion start pulse
adend	Output	Conversion end pulse
calend	Output	Calibration end signal
data[9:0]	Output	Digital Output [9:0]
DVDD	Power	Digital Power
DVSS	Ground	Digital Ground

5. Function description

This SAR-type ADC contains a SAR register, an auto-zero comparator, three internal DACs, a mux(8x1), a format converter, a clock & phase generator, and a reference ladder & calibrator. The conversion rate ranges from 2Mhz to 16Mhz. These blocks contained in ADC can be described as follows:

5.1 SAR register

This block is a successive approximation register which latches the output of comparator and generates the input of the internal DACs.

5.2 Auto-zero comparator

This comparator is able to reduce the offset error periodically and senses the difference between analog input and DAC's output.

5.3 Internal DACs

These DACs generate analog reference voltage according to SAR register output.

5.4 Multiplexer

One of the eight channel can be selected by the control pins (ach[0] ~ ach[7])

5.5 Format converter

This format converter is to latch the 11-bit SAR output data stream and convert it to a standard 10-bit binary format.

5.6 Clock & Phase generator

The outputs generated in clock & phase generator control SAR-type ADC conversion operation.

5.7 adst & adend, calend pulse

The adst pulse makes ADC start new. $2 \text{ aclk} \leq \text{adst pulse width} < \text{always "high"}$

The adend pulse knows each end point of the internal conversion.

The calend signal knows the valid time point of the conversion output data. But Before the calend signal is active high, ADC output data is useful data.

Normal operation

- . aiostop : low
- . $an0 \sim an7 \leq avref \leq AVDD$
- . aclk : 2MHz ~ 16MHz
- . $an0 \sim an7 : 0 \sim avref$
- . adst : low
- . Analog input selection

Pin(High)	ach[0]	ach[1]	ach[2]	ach[3]	ach[4]	ach[5]	ach[6]	ach[7]
Channel	an0	an1	an2	an3	an4	an5	an6	an7

6. Operation Conditions

Symbol	Parameter	Min.	Max.	Units
AVDD	Power Supply	1.6	2.0	V
DVDD		1.6	2.0	V
an	Analog Input	0	avref	V
T _{PWL}	Clock pulse width (@8MHz)	62.5		ns
T _{PWH}		62.5		ns
Top	Operation Temperature	0	100	°C

7. Electrical characteristic

(Analog input frequency $f_{in}=2\text{Khz}$, $aclk = 8\text{ Mhz}$, $AVDD=DVDD=avref=1.8\text{V}$ $T= 25\text{ }^{\circ}\text{C}$)

	Parameter	Conditions	Min.	Typ.	Max.	Units
I_{dd}	Normal	$aclk=8\text{MHz}$ Input= $avref$ $f_{in}=2\text{kHz ramp}$		1	2	mA
	Power Down			5nA	10uA	
AN	Analog input voltage		0		$avref$	V
Accuracy	Resolution		8	10		bits
INL	Integral Nonlinearity	$aclk = 8\text{MHz}$ Input = $0-avref(V)$ ($f_{in} = 2\text{kHz ramp}$)			± 1.0	LSB
DNL	Differential Nonlinearity	$aclk = 8\text{MHz}$ Input = $0 -avref(V)$ ($f_{in} = 2\text{kHz ramp}$)			± 2.0	LSB
SNR	Signal-to-Noise Ratio	$aclk=8\text{MHz}$, $f_{in} = 2\text{KHz}$	50	54		dB
SNDR	Signal-to-Noise Distortion Ratio		48	52		dB
$aclk$	External clock		2	8	16	MHz
t_c	Conversion time		1	4	8	us
$avref$	Analog Reference Voltage				AVDD	V
T_{cal}	Power up time	Calibration time		22		ms
THD	Total harmonic distortion		50	54		dB
AVDD	Analog power		1.6	1.8	2.0	V
DVDD	Digital power		1.6	1.8	2.0	V

8. Timing Diagram

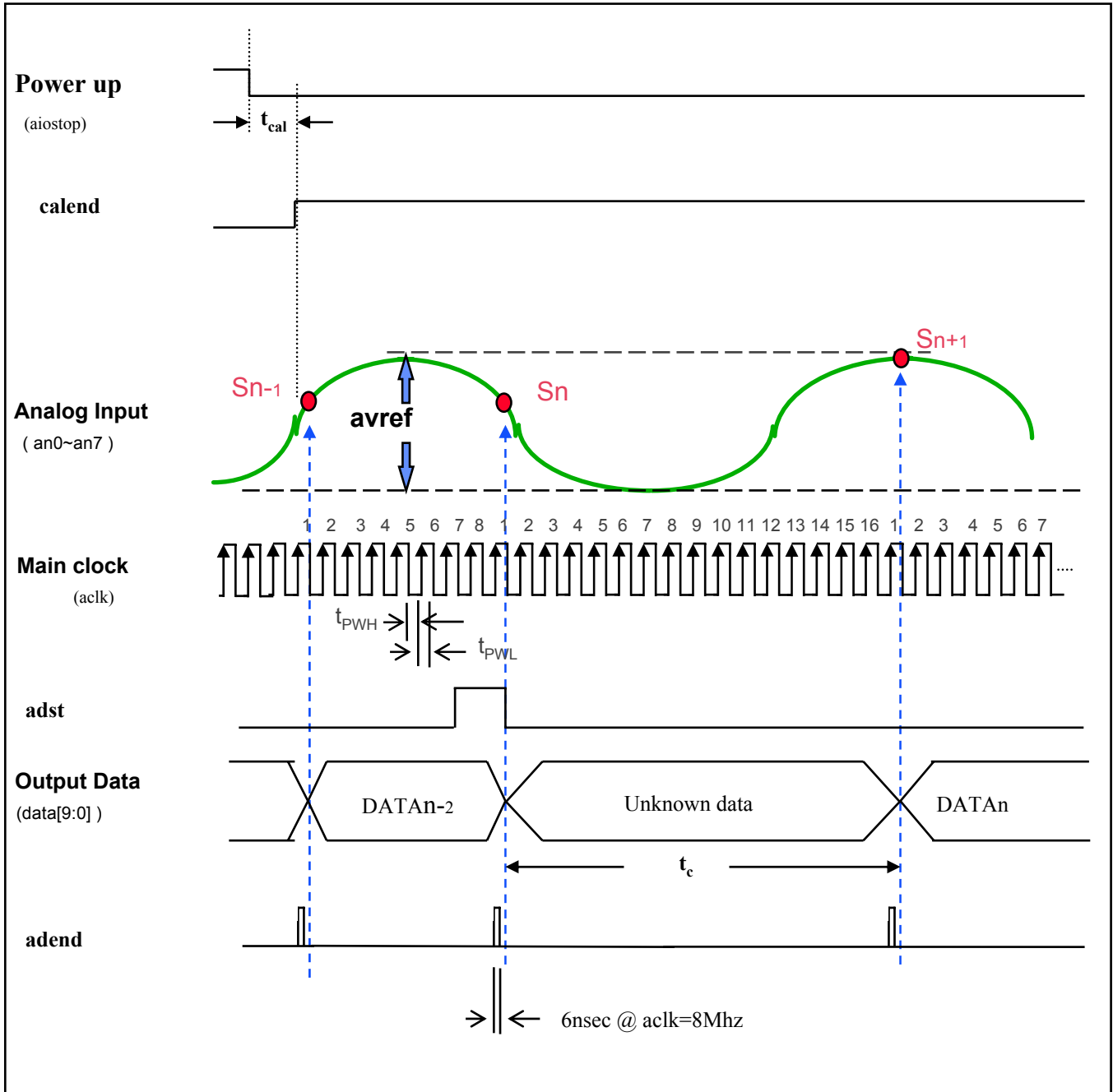

9. Layout Guide

Power Supply De-coupling

The analog power and the digital power of the H18GAD32S should be separated from each other to prevent the glitch which is coupled into the analog power from digital circuitry. The I/O powers are also separated as shown in figure 1. And the digital power of H18GAD32S must be separated from main chip power.

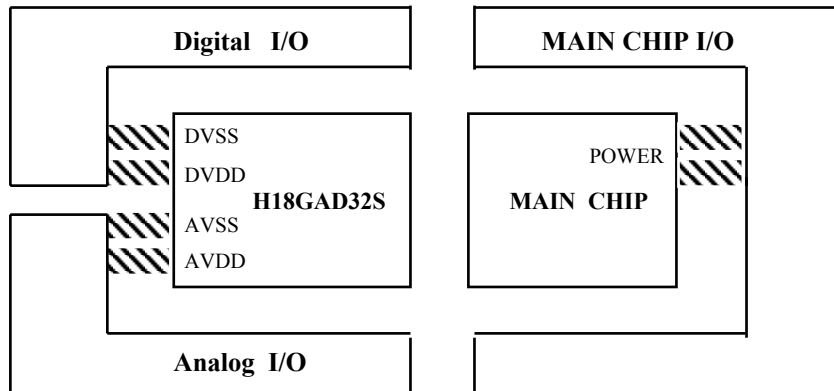

Figure 1. Recommended power scheme

Analog pad

The PC3D00 can be used as an analog I/O pad.

Analog signals

The analog signals, such as an0~an7, avref must be drawn wider than connector width from ADC core to pad because of large current flow.

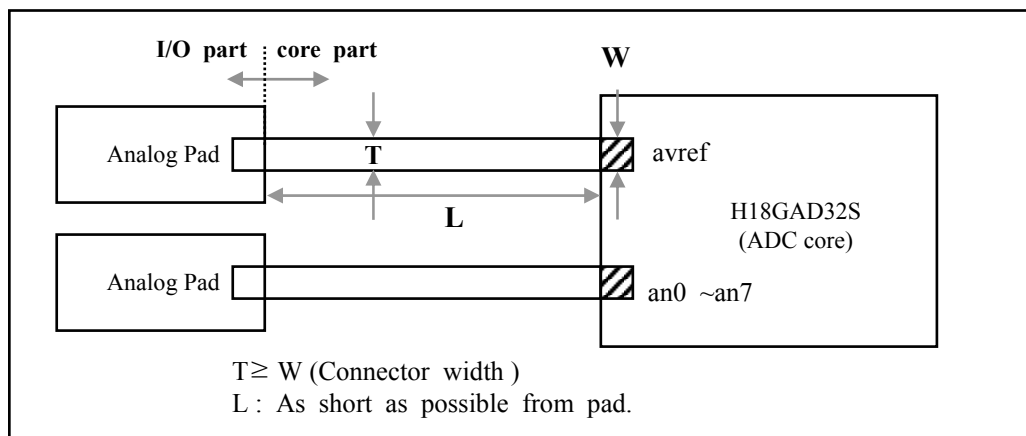

Figure 2. Analog pads connection

Analog pad routing

-avref, an[0]~an[7]: Using AVDD, AVSS

-data[0:9], aiostop, adst, aclk, adend, calend, ach[0]~ach[7]: Using DVDD, DVSS

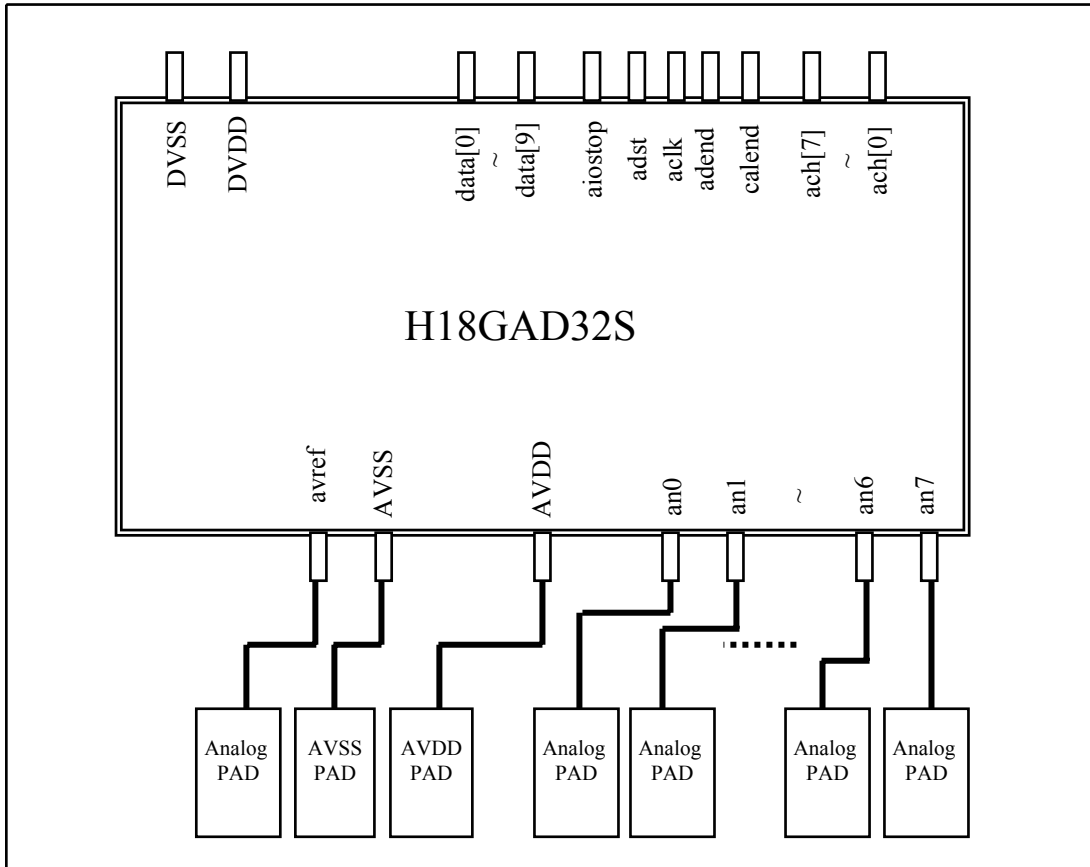

Figure 3. Analog power routing