

Features

- Operating voltage : 2.0V~3.6V
- Operating current
 - ♦ 0.35μA (Typ.) @3.3V, Deep Sleep Mode
 - ♦ 4.3mA (Typ.) @3.3V, 433MHz RX 50Kbps
 - ♦ 4.7mA (Typ.) @3.3V, 433MHz RX 250Kbps
 - ♦ 22.0mA (Typ.) @3.3V, 433MHz TX 10dBm
- Receiver sensitivity
 - ♦ -113/-113dBm (Typ.) @ 3.3V, 433/868MHz, 10K Symbol Rate & BER=0.1%
 - ♦ -110/-108dBm (Typ.) @ 3.3V, 433/868MHz, 50K Symbol Rate & BER=0.1%
 - ♦ -102/-101dBm (Typ.) @ 3.3V, 433/868MHz, 250K Symbol Rate & BER=0.1%

- Maximum operating input power: 10dBm @RF-in, BER=0.1%
- Modulation type: FSK/GFSK
- Interface: 12-pin stamp hole
- Dimension: 15.0mm(L)×18.5mm(W)×2.5mm(H)
- Operating temperature: -40°C~85°C

General Description

The BM3602-0x-1 is designed based on the BC3602 device and which forms a Sub-1GHz FSK/GFSK transceiver module. The module can be used for wireless applications in the 315MHz, 433MHz, 470MHz, 868MHz and 915MHz ISM (Industrial, Scientific and Medical) bands. The host MCU can communicate with the device via a 3 or 4 wire SPI interface for wireless data communications.

Selection Table

Part Number	Frequency Band
BM3602-03-1	315MHz
BM3602-04-1	433MHz
BM3602-08-1	868MHz
BM3602-09-1	915MHz

Pin Definition

Pin No.	Pin Name	Type	Function Description
1	AGND	P	Connect to ground
2	VDD	P	Power supply
3	CSN	DI	SPI chip select, low active
4	GIO1	P	Multi-function I/O 1
5	GIO2	DI/DO	Multi-function I/O 2
6	SDIO	DI/DO	SPI data input/output
7	SCK	DI	SPI clock input
8	GIO3	DI/DO	Multi-function I/O 3
9	GIO4	DI/DO	Multi-function I/O 4
10	AGND	P	Connect to ground
11	ANT	AI	Antenna input
12	AGND	P	Connect to ground

Note: DI = Digital input; DO = Digital output; AI: Analog input; P = Power.

Module Dimension Drawing

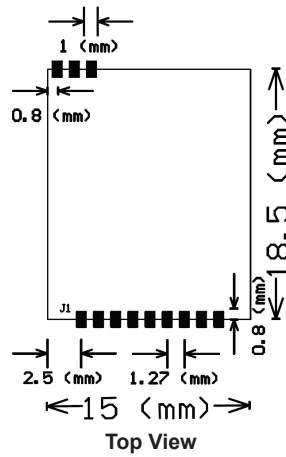

Module Circuit

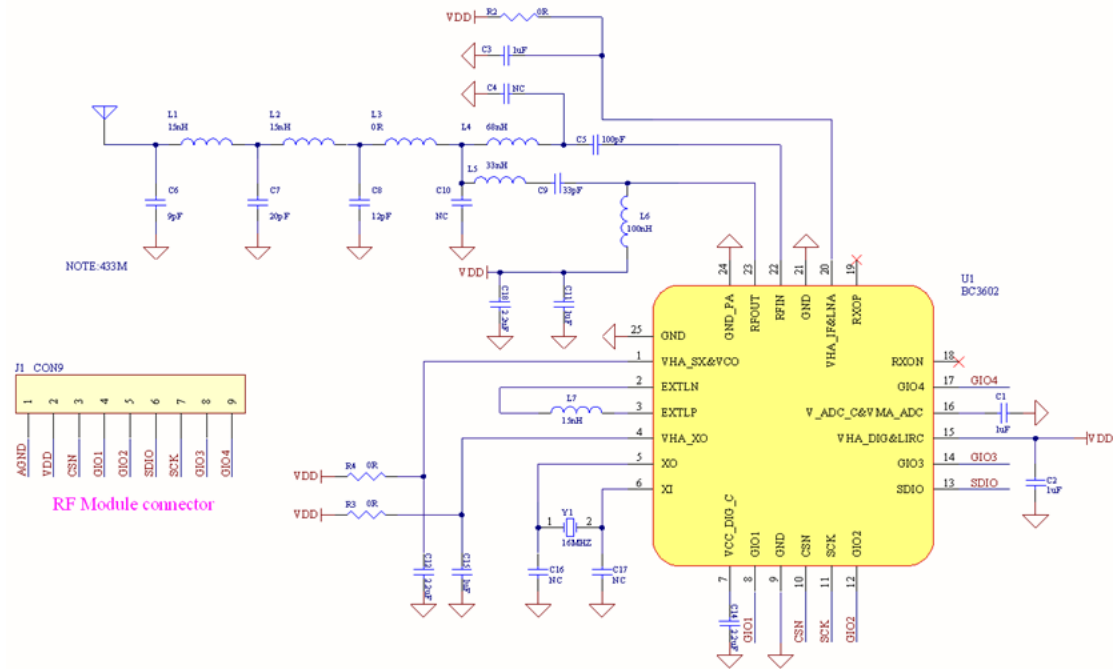

Module Figure

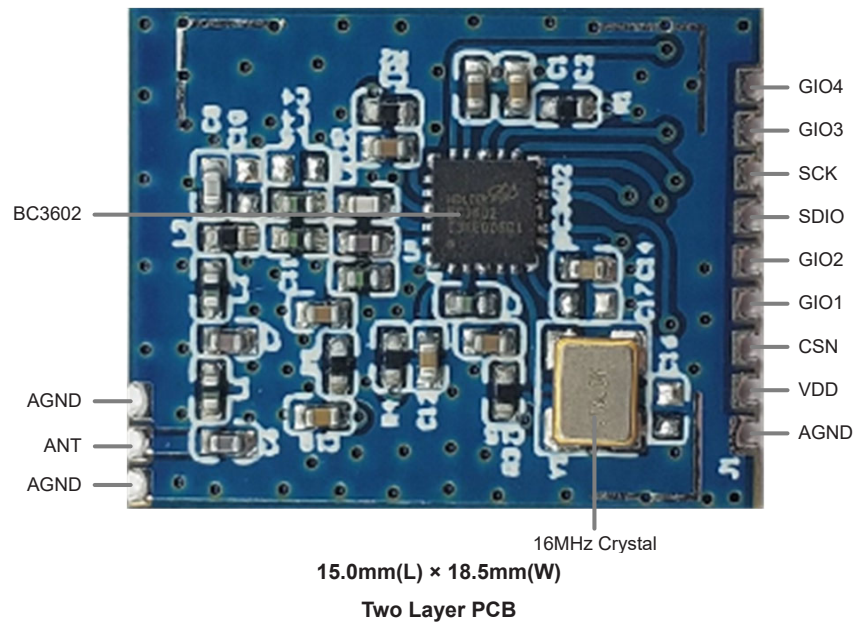

Module Points to Note

1. The recommended module crystal CL setup value is 0x41. The recommended 433MHz band Tx Power setup value is 0x05(5dBm), 0x09(10dBm), 0x0D(13dBm).
2. When attaching the module it is not recommended to have traces underneath the module on the reverse side of the PCB. The diagram shows a practical application.

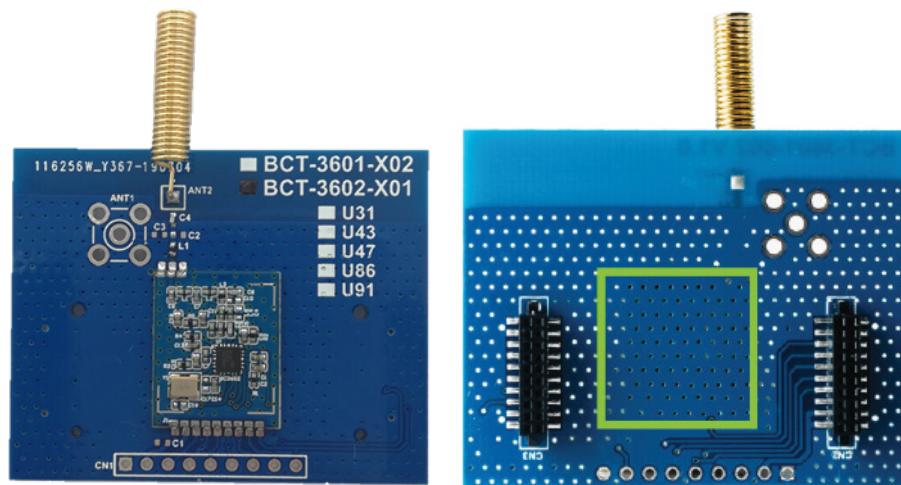

Note: It is not recommended to have traces within the green frame area.

3. In practical applications ensure that metallic objects are kept as far away as possible from the antenna.

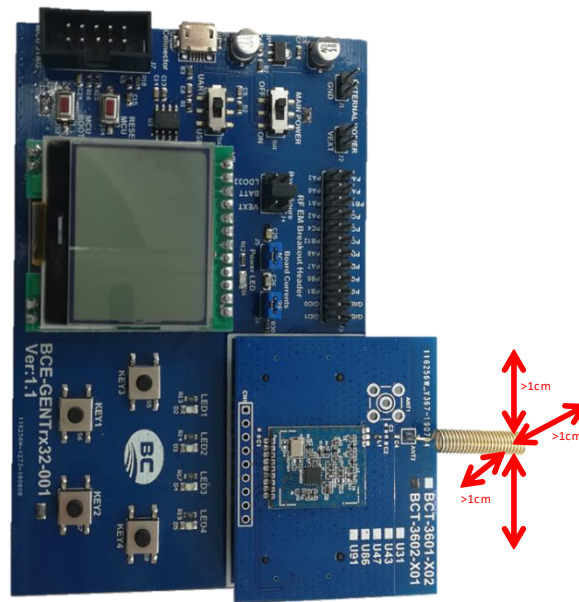

Bill of Material (433.92MHz)

Item	Comp.	Description	Size	Value	Tol.	Part Number
1	C1	X5R ceramic capacitor	0402	1 μ F	$\pm 10\%$	
2	C2	X5R ceramic capacitor	0402	1 μ F	$\pm 10\%$	
3	C3	X5R ceramic capacitor	0402	1 μ F	$\pm 10\%$	
4	C5	NPO ceramic capacitor	0402	100pF	$\pm 5\%$	
5	C6	NPO ceramic capacitor	0402	9pF	$\pm 0.25\%$	
6	C7	NPO ceramic capacitor	0402	20pF	$\pm 5\%$	
7	C8	NPO ceramic capacitor	0402	12pF	$\pm 5\%$	
8	C9	NPO ceramic capacitor	0402	33pF	$\pm 5\%$	
9	C11	X5R ceramic capacitor	0402	1 μ F	$\pm 10\%$	
10	C12	X7R ceramic capacitor	0402	2.2 μ F	$\pm 10\%$	
11	C14	X7R ceramic capacitor	0402	2.2 μ F	$\pm 10\%$	
12	C15	X5R ceramic capacitor	0402	1 μ F	$\pm 10\%$	
13	C18	X7R ceramic capacitor	0402	2.2 μ F	$\pm 10\%$	
14	R2	Resistor	0402	0R		
15	R3	Resistor	0402	0R		
16	R4	Resistor	0402	0R		
17	L3	Resistor	0402	0R		
18	L1	Inductor	0402	15nH		MURATA: LQG15HS15NJ02D
19	L2	Inductor	0402	15nH		MURATA: LQG15HS15NJ02D
20	L4	Inductor	0402	68nH		MURATA: LQG15HS68NJ02D
21	L5	Inductor	0402	33nH		MURATA: LQG15HS33NJ02D
22	L6	Inductor	0402	100nH		MURATA: LQG15HS100NJ02D
23	L7	Inductor	0402	15nH		MURATA: LQG15HS15NJ02D
24	U1	IC	24QFN	BC3602		HOLTEK
25	Y	Crystal	S3225A	16MHz		YOKETAN: ± 20 PPM, CL12PF

Copyright© 2020 by HOLTEK SEMICONDUCTOR INC.

The information appearing in this Data Sheet is believed to be accurate at the time of publication. However, Holtek assumes no responsibility arising from the use of the specifications described. The applications mentioned herein are used solely for the purpose of illustration and Holtek makes no warranty or representation that such applications will be suitable without further modification, nor recommends the use of its products for application that may present a risk to human life due to malfunction or otherwise. Holtek's products are not authorized for use as critical components in life support devices or systems. Holtek reserves the right to alter its products without prior notification. For the most up-to-date information, please visit our web site at <http://www.holtek.com>.