

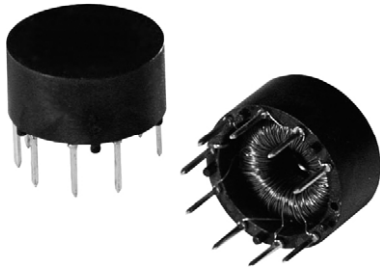

Through Hole Transformers Converter



ELECTRICAL SPECIFICATIONS

Transformer power rating: 3 W

Isolation, primary - secondary: 500 V, 60 Hz. Operating characteristics may be varied to suit specific applications by appropriate selection of circuit components

FEATURES

- Designed especially for low-power solid state circuits
- Designed for mounting on printed circuit boards
- Miniature size for minimum space
- High conversion efficiency from DC input to filtered DC output
- Material categorization: for definitions of compliance please see www.vishay.com/doc?99912



RoHS
COMPLIANT

APPLICATIONS

Power supply for gas discharge display, battery-operated portable instruments, operational amplifier power supplies

MECHANICAL SPECIFICATIONS

Coil: secured to bottom of case with epoxy

Terminals: 0.025" [0.635 mm] square, solder plated

OPERATING TEMPERATURE RANGE

-20 °C to +80 °C. Intended for use in enclosed commercial and industrial applications

STANDARD ELECTRICAL SPECIFICATIONS						
MODEL	INPUT (V _{DC})	OUTPUT	FREQUENCY REFERENCE (kHz)	CIRCUIT EFFECTIVE	TEST CIRCUIT	SCHEMATIC NUMBER
TC-10-01B	3.6	+ 7.2 ± 0.2 V _{DC} at 150 MW	7.5	50 %	1	1
		- 7.2 ± 0.2 V _{DC} at 150 MW				
TC-10-02B	5	200 ± 10 V _{DC} at 250 MW	11	50 %	2 ⁽¹⁾	4
TC-10-03B	5	200 ± 10 V _{DC} at 250 MW	11	60 %	2	2
		+ 15 ± 0.4 V _{DC} at 125 MW				
		- 15 ± 0.4 V _{DC} at 125 MW				
TC-10-04B	5	+ 15 ± 0.4 V _{DC} at 500 MW	8	75 %	3	1
		- 15 ± 0.4 V _{DC} at 500 MW				
TC-10-05B	5	+ 170 ± 5.1 V _{DC} at 850 MW	11	75 %	4	5
		+ 32 ± 1.0 V _{DC} at 510 MW				
TC-10-06B	5	+ 35 ± 1.0 V _{DC} at 610 MW	11	70 %	4 ⁽¹⁾	5 ⁽¹⁾
TC-10-07B	7.5	16.3 ± 0.4 V _{DC} at 330 MW	7	65 %	5	1
TC-10-08B	12	± 15 ± 0.4 V _{DC} at 1 W	7.5	72 %	3	1
TC-10-09B	12	160 ± 5 V _{DC} at 1.5 W	10	75 %	6	3
TC-10-10B	12	14.2 ± 0.7 V _{DC} at 3 W	10	70 %	5	1
TC-10-11B	12	+ 24 ± 0.5 V _{DC} at 2 W	10	80 %	5	1
TC-10-12B	24	170 ± 5.1 V _{DC} at 850 MW	11	70 %	4	5
		32 ± 1.0 V _{DC} at 510 MW				

Note

⁽¹⁾ Specifications relate to transformer when operated in applicable test circuit and at specified load power.

TEST CIRCUITS

TEST CIRCUIT NUMBER 1

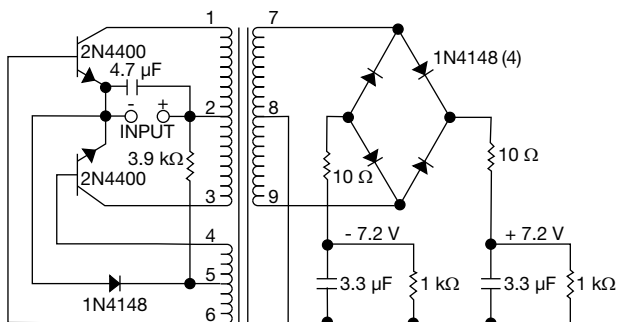

TEST CIRCUIT NUMBER 2

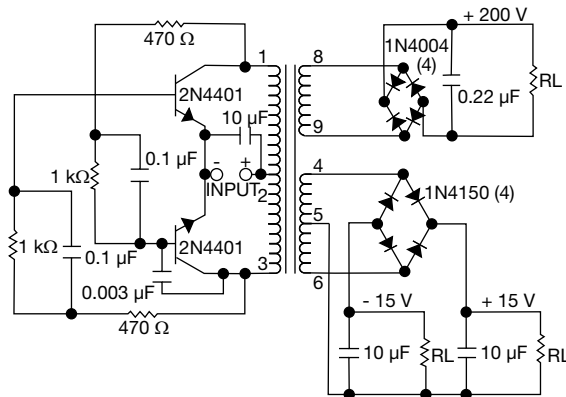

TEST CIRCUIT NUMBER 3

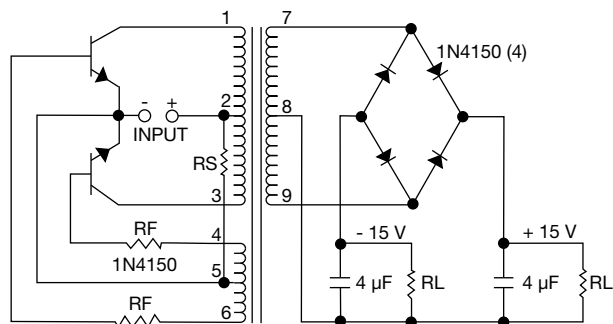

TEST CIRCUIT NUMBER 4

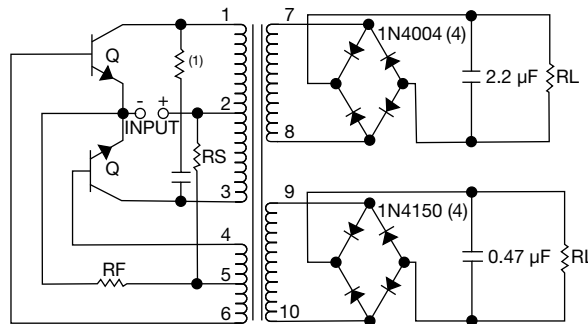

TEST CIRCUIT NUMBER 5

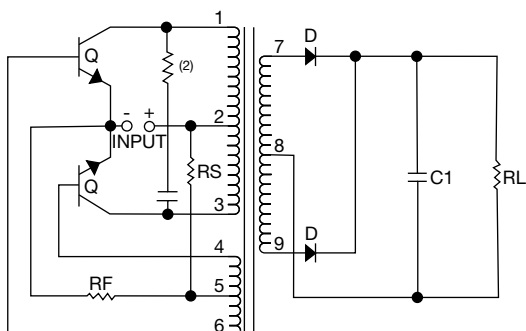

TEST CIRCUIT NUMBER 6

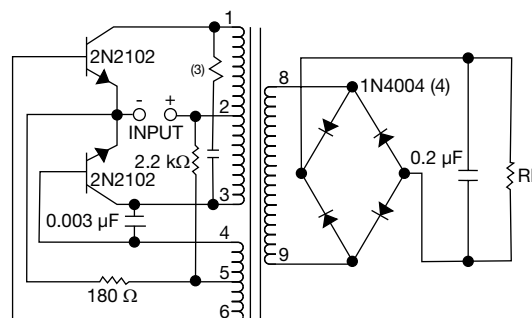

Notes

- Omit winding 4, 5, 6 and associated circuit to test TC-10-028.
- Omit winding 7, 8 and associated circuit to test TC-10-068.
- (1) RC network may be required to suppress spurious oscillations. R = 100 Ω, C = 0.001 μF.
- (2) RC network may be required to suppress spurious oscillations.
- (3) RC network may be required to suppress spurious oscillations. R = 10 Ω, C = 0.004 μF.

SCHEMATICS		
<p>1.</p>	<p>2.</p>	<p>3.</p>
<p>4.</p>	<p>5.</p>	

Note

(1) Omit high voltage winding for TC-10-06.

DIMENSIONS in inches [millimeters]

Note

(1) Shows typical pin spacing, pin 10 is omitted on all models except -05, -06, -12.

PART MARKING
- Model
- Date code

ORDERING INFORMATION			
TC-10	-01B	EB	e2
MODEL	DASH NUMBER	PACKAGE CODE	JEDEC® LEAD (Pb)-FREE STANDARD

GLOBAL PART NUMBER											
<table border="1"> <tr> <td>T</td> <td>C</td> <td>1</td> <td>0</td> </tr> </table> <p>MODEL</p>	T	C	1	0	<table border="1"> <tr> <td>E</td> <td>B</td> </tr> </table> <p>PACKAGE CODE</p>	E	B	<table border="1"> <tr> <td>0</td> <td>1</td> <td>B</td> </tr> </table> <p>INDUCTANCE VALUE</p>	0	1	B
T	C	1	0								
E	B										
0	1	B									



Disclaimer

ALL PRODUCT, PRODUCT SPECIFICATIONS AND DATA ARE SUBJECT TO CHANGE WITHOUT NOTICE TO IMPROVE RELIABILITY, FUNCTION OR DESIGN OR OTHERWISE.

Vishay Intertechnology, Inc., its affiliates, agents, and employees, and all persons acting on its or their behalf (collectively, "Vishay"), disclaim any and all liability for any errors, inaccuracies or incompleteness contained in any datasheet or in any other disclosure relating to any product.

Vishay makes no warranty, representation or guarantee regarding the suitability of the products for any particular purpose or the continuing production of any product. To the maximum extent permitted by applicable law, Vishay disclaims (i) any and all liability arising out of the application or use of any product, (ii) any and all liability, including without limitation special, consequential or incidental damages, and (iii) any and all implied warranties, including warranties of fitness for particular purpose, non-infringement and merchantability.

Statements regarding the suitability of products for certain types of applications are based on Vishay's knowledge of typical requirements that are often placed on Vishay products in generic applications. Such statements are not binding statements about the suitability of products for a particular application. It is the customer's responsibility to validate that a particular product with the properties described in the product specification is suitable for use in a particular application. Parameters provided in datasheets and / or specifications may vary in different applications and performance may vary over time. All operating parameters, including typical parameters, must be validated for each customer application by the customer's technical experts. Product specifications do not expand or otherwise modify Vishay's terms and conditions of purchase, including but not limited to the warranty expressed therein.

Except as expressly indicated in writing, Vishay products are not designed for use in medical, life-saving, or life-sustaining applications or for any other application in which the failure of the Vishay product could result in personal injury or death. Customers using or selling Vishay products not expressly indicated for use in such applications do so at their own risk. Please contact authorized Vishay personnel to obtain written terms and conditions regarding products designed for such applications.

No license, express or implied, by estoppel or otherwise, to any intellectual property rights is granted by this document or by any conduct of Vishay. Product names and markings noted herein may be trademarks of their respective owners.