

16 M-WORD BY 72-BIT DDR SYNCHRONOUS DYNAMIC RAM MODULE

REGISTERED TYPE

Description

The MC-45D16DA721 is a 16,777,216 words by 72 bits DDR synchronous dynamic RAM module on which 9 pieces of 128M DDR SDRAM: μ PD45D128842 are assembled.

These modules provide high density and large quantities of memory in a small space without utilizing the surface-mounting technology on the printed circuit board.

Decoupling capacitors are mounted on power supply line for noise reduction.

Features

- 16,777,216 words by 72 bits organization (ECC type)
- Clock frequency

Part number	/CAS latency	Clock frequency (MAX.)
MC-45D16DA721KF-C75	CL = 2.5	133 MHz
	CL = 2	100 MHz
MC-45D16DA721KF-C80	CL = 2.5	125 MHz
	CL = 2	100 MHz

- Fully Synchronous Dynamic RAM with all signals except DM, DQS and DQ referenced to a positive clock edge
- Double Data Rate interface
 - Differential CLK (/CLK) input
 - Data inputs and DM are synchronized with both edges of DQS
 - Data outputs and DQS are synchronized with a cross point of CLK and /CLK
- Quad internal banks operation
- Possible to assert random column address in every clock cycle
- Programmable Mode register set
 - /CAS latency (2, 2.5)
 - Burst length (2, 4, 8)
 - Wrap sequence (Sequential / Interleave)
- Automatic precharge and controlled precharge
- CBR (Auto) refresh and self refresh
- 2.5 V \pm 0.2 V Power supply for V_{DD}
- 2.5 V \pm 0.2 V Power supply for V_{DDQ}
- SSTL_2 compatible with all signals
- 4,096 refresh cycles / 64 ms
- Burst termination by Precharge command and Burst stop command
- 184-pin dual in-line memory module (Pin pitch = 1.27 mm)
- Registered type
- Serial PD

The information in this document is subject to change without notice. Before using this document, please confirm that this is the latest version.

Not all devices/types available in every country. Please check with local NEC representative for availability and additional information.

Ordering Information

Part number	Clock frequency (MAX.)	Package	Mounted devices
MC-45D16DA721KF-C75	133 MHz	184-pin Dual In-line Memory Module (Socket Type)	9 pieces of μ PD45D128842G5 (Rev. K) (10.16 mm (400) TSOP (II))
MC-45D16DA721KF-C80	125 MHz	Edge connector: Gold plated 43.18 mm height	

Pin Configuration

184-pin Dual In-line Memory Module Socket Type (Edge connector: Gold plated)

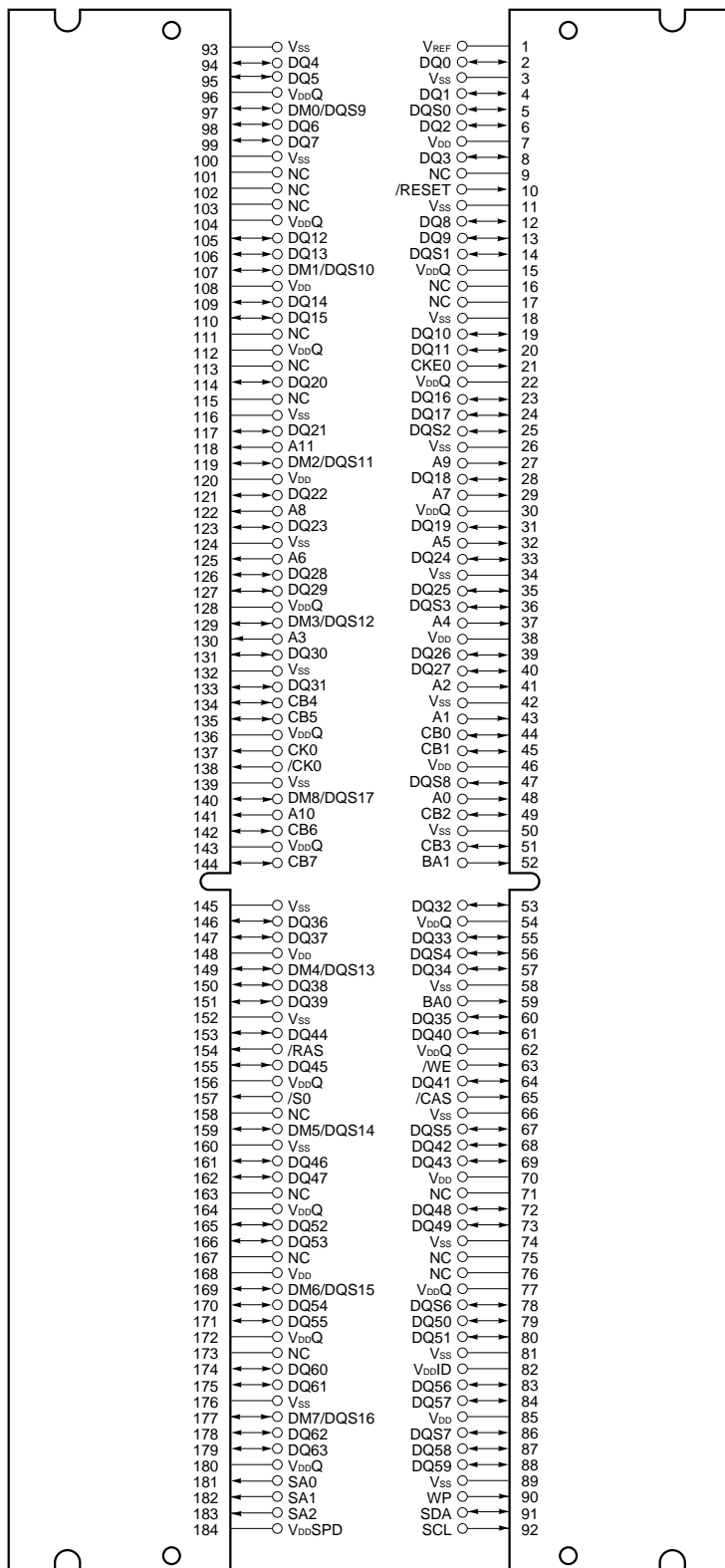

/xxx indicates active low signal.

- A0 - A11 : Address Inputs
- [Row: A0 - A11, Column: A0 - A9]
- BA0, BA1 : SDRAM Bank Select
- DQ0 - DQ63, CB0 - CB7: Data Inputs/Outputs
- CK0 : Clock Input
- (positive line of differential pair)
- /CK0 : Clock Input
- (negative line of differential pair)
- CKE0 : Clock Enable Input
- WP : Write Protect
- /S0 : Chip Select Input
- /RAS : Row Address Strobe
- /CAS : Column Address Strobe
- /WE : Write Enable
- DQS0 - DQS8 : Low Data Strobe
- DM(0 - 8) / DQS(9 - 17) : Low Data Masks / High Data Strobe
- SA0 - SA2 : Address Input for EEPROM
- SDA : Serial Data I/O for PD
- SCL : Clock Input for PD
- VDD : Power Supply
- VSS : Ground
- VDDID : VDD Identification Flag
- VDDQ : Power Supply for DQ and DQS
- VREF : Input Reference
- VDDSPD : Power supply for EEPROM
- NC : No Connection
- /RESET : Reset Input

Block Diagram

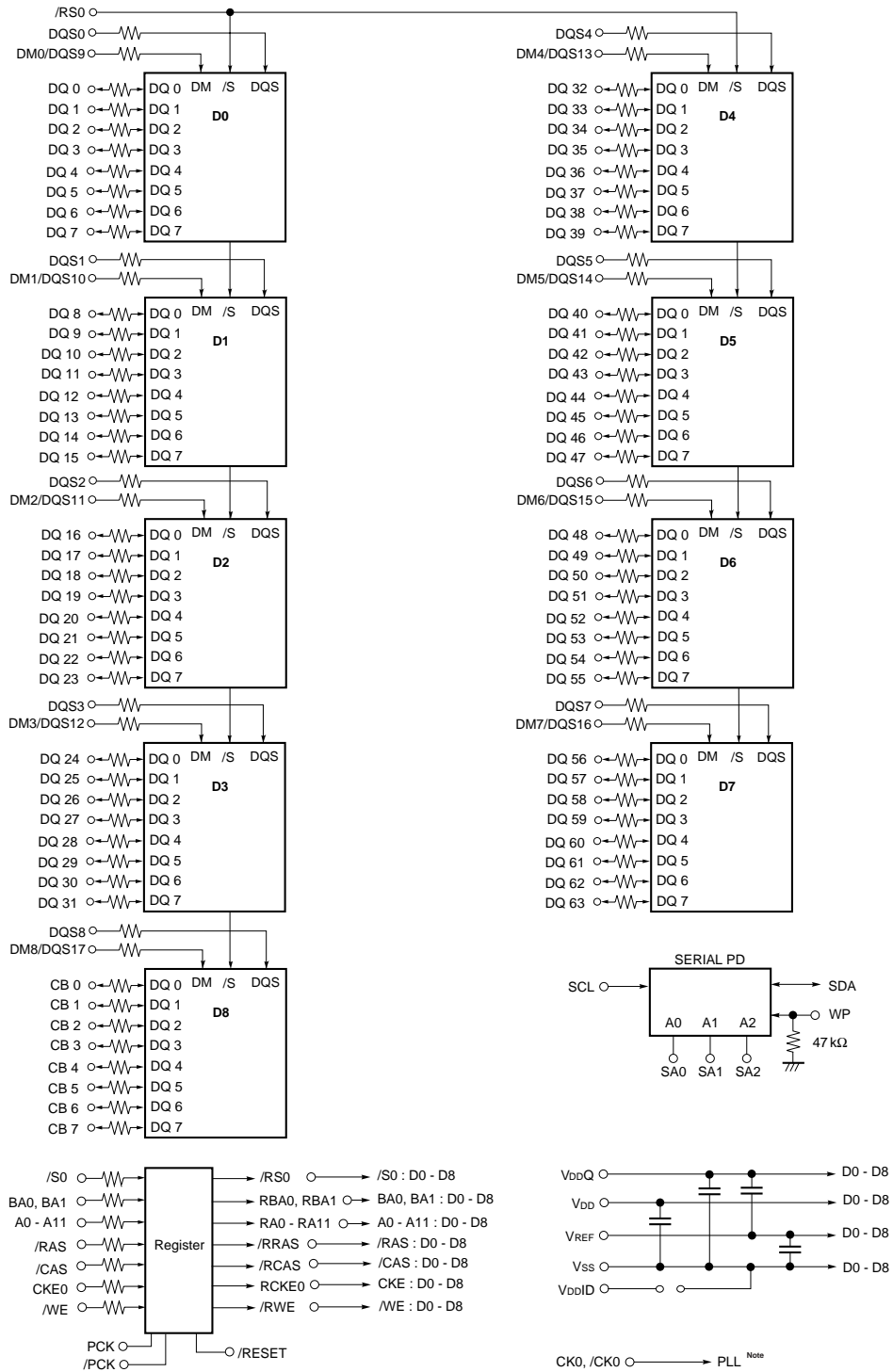

Note Wire per Clock Loading Table/Wiring Diagrams.

- Remarks**
1. The value of all resistors of DQs is 10 Ω.
 2. D0 – D8: μ PD45D128842 (4M words \times 8 bits \times 4 banks)

Electrical Specifications

- All voltages are referenced to V_{SS} (GND).
- After power up, wait more than 1 ms and then, execute **Power on sequence and CBR (auto) refresh** before proper device operation is achieved.

Absolute Maximum Ratings

Parameter	Symbol	Condition	Rating	Unit
Voltage on power supply pin relative to V _{SS}	V _{DD} , V _{DDQ}		-0.5 to +3.6	V
Voltage on input pin relative to V _{SS}	V _T		-0.5 to +3.6	V
Short circuit output current	I _O		50	mA
Power dissipation	P _D		12	W
Storage temperature	T _{sig}		-55 to +125	°C

Caution Exposing the device to stress above those listed in Absolute Maximum Ratings could cause permanent damage. The device is not meant to be operated under conditions outside the limits described in the operational section of this specification. Exposure to Absolute Maximum Rating conditions for extended periods may affect device reliability.

Recommended Operating Conditions

Parameter	Symbol	Condition	MIN.	TYP.	MAX.	Unit
Supply voltage	V _{DD}		2.3	2.5	2.7	V
Supply voltage for DQ, DQS	V _{DDQ}		2.3	2.5	2.7	V
Input reference voltage	V _{REF}		0.49 × V _{DDQ}		0.51 × V _{DDQ}	V
Termination voltage	V _{TT}		V _{REF} - 0.04	V _{REF}	V _{REF} + 0.04	V
High level dc input voltage	V _{IH} (DC)		V _{REF} + 0.15		V _{DD} + 0.3	V
Low level dc input voltage	V _{IL} (DC)		-0.3		V _{REF} - 0.15	V
Input differential voltage (CLK and /CLK)	V _{ID} (DC)		0.36		V _{DDQ} + 0.6	V
Input crossing point voltage (CLK and /CLK)	V _{IX}		0.5 × V _{DDQ} - 0.2		0.5 × V _{DDQ} + 0.2	V
Operating ambient temperature	T _A		0		70	°C

Capacitance (T_A = 25 °C, f = 100 MHz)

Parameter	Symbol	Test condition	MIN.	TYP.	MAX.	Unit
Input capacitance	C _{I1}	A0 - A11, BA0, BA1, /RAS, /CAS, /WE	TBD		TBD	pF
	C _{I2}	CK0, /CK0	TBD		TBD	
	C _{I3}	CKE0	TBD		TBD	
	C _{I4}	/S0	TBD		TBD	
Data input/output capacitance	C _{I/O1}	DM(0-8)/DQS(9-17), DQS0 - DQS8	TBD		TBD	pF
	C _{I/O2}	DQ0 - DQ63, CB0 - CB7	TBD		TBD	

DC Characteristics 1 (Recommended Operating Conditions unless otherwise noted)

Parameter	Symbol	Test condition	/CAS latency	Grade	MIN.	MAX.	Unit	Notes
Operating current (ACT-PRE)	I _{DD0}	t _{RC} = t _{RC(MIN.)} , t _{CK} = t _{CK(MIN.)} , One bank, Active-precharge, DQ, DM and DQS inputs changing twice per clock cycle, Address and control inputs changing once per clock cycle		-C75		TBD	mA	1
				-C80		TBD		
Operating current (ACT-READ-PRE)	I _{DD1}	t _{RC} = t _{RC(MIN.)} , t _{CK} = t _{CK(MIN.)} , One bank, Active-read-precharge, I _O = 0 mA, Burst length = 2, Address and control inputs changing once per clock cycle	CL = 2	-C75		TBD	mA	
				-C80		TBD		
			CL = 2.5	-C75		TBD		
				-C80		TBD		
Precharge power down standby current	I _{DD2P}	CKE ≤ V _{IL(MAX.)} , t _{CK} = t _{CK(MIN.)} , All banks idle, Power down mode				TBD	mA	
Idle standby current	I _{DD2N}	CKE ≥ V _{IH(MIN.)} , t _{CK} = t _{CK(MIN.)} , /CS ≥ V _{IH(MIN.)} , All banks idle, Address and other control inputs changing once per clock cycle				TBD	mA	
Active power down standby current	I _{DD3P}	CKE ≤ V _{IL(MAX.)} , t _{CK} = t _{CK(MIN.)} , One bank active, Power down mode				TBD	mA	
Active standby current	I _{DD3N}	/CS ≥ V _{IH(MIN.)} , CKE ≥ V _{IH(MIN.)} , t _{CK} = t _{CK(MIN.)} , t _{RC} = t _{TRAS(MAX.)} , One bank, Active-precharge, DQ, DM and DQS inputs changing twice per clock cycle, Address and other control inputs changing once per clock cycle				TBD	mA	
Operating current (Burst read)	I _{DD4R}	t _{CK} = t _{CK(MIN.)} , Continuous burst read, Burst length = 2, I _O = 0mA, One bank active, Address and control inputs changing once per clock cycle	CL = 2	-C75		TBD	mA	2
				-C80		TBD		
			CL = 2.5	-C75		TBD		
				-C80		TBD		
Operating current (Burst write)	I _{DD4W}	t _{CK} = t _{CK(MIN.)} , Continuous burst write, Burst length = 2, One bank active, Address and control inputs changing once per clock cycle	CL = 2	-C75		TBD	mA	2
				-C80		TBD		
			CL = 2.5	-C75		TBD		
				-C80		TBD		
CBR (auto) refresh current	I _{DD5}	t _{RFC} = t _{RFC(MIN.)}		-C75		TBD	mA	
				-C80		TBD		
Self refresh current	I _{DD6}	CKE ≤ 0.2 V				TBD	mA	

Notes 1. I_{DD1} depends on output loading and cycle rates. Specified values are obtained with the output open.

2. I_{DD4R} and I_{DD4W} depend on output loading and cycle rates. Specified values are obtained with the output open.

DC Characteristics 2 (Recommended Operating Conditions unless otherwise noted)

Parameter	Symbol	Test condition	MIN.	MAX.	Unit	Notes
Input leakage current	I _{I(L)}	V _I = 0 to 3.6 V, all other pins not under test = 0 V	TBD	TBD	μA	
Output leakage current	I _{O(L)}	D _{OUT} is disabled, V _O = 0 to V _{DDQ} + 0.3 V	TBD	TBD	μA	
Output high current	I _{OH}	V _{OUT} = V _{DDQ} - 0.43 V	TBD		mA	
Output low current	I _{OL}	V _{OUT} = 0.35 V	TBD		mA	

AC Characteristics (Recommended Operating Conditions unless otherwise noted)

Test Conditions

Parameter	Symbol	Value	Unit	Notes
Input Reference voltage (Input timing measurement reference level)	V_{REF}	$V_{DDQ} \times 0.5$	V	
Termination voltage (Output timing measurement reference level)	V_{TT}	V_{REF}	V	1
High level ac input voltage	$V_{IH(ac)}$	$V_{REF} + 0.31$	V	
Low level ac input voltage	$V_{IL(ac)}$	$V_{REF} - 0.31$	V	
Input differential voltage (CK0 and /CK0)	$V_{ID(ac)}$	0.7	V	
Input signal slew rate	SLEW	1	V/ns	2

- Notes**
1. Output waveform timing is measured where the output signal crosses through the V_{TT} level.
 2. Slew rate is to be maintained in the $V_{IL(ac)}$ to $V_{IH(ac)}$ range of the input signal swing. $SLEW = (V_{IH(ac)} - V_{IL(ac)}) / \Delta t$

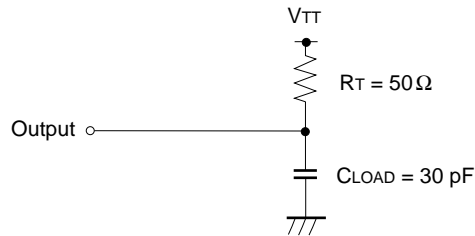

Synchronous Characteristics

Parameter		Symbol	-C75 (PC266B)		-C80 (PC200)		Unit	Note
			MIN.	MAX.	MIN.	MAX.		
Clock cycle time	CL = 2.5	t _{CK}	7.5	15	8	15	ns	
	CL = 2		10	15	10	15		
CLK high-level width		t _{CH}	0.45	0.55	0.45	0.55	t _{CK}	
CLK low-level width		t _{CL}	0.45	0.55	0.45	0.55	t _{CK}	
DQ output access time from CLK, /CLK		t _{AC}	-0.75	0.75	-0.8	0.8	ns	
DQS output access time from CLK, /CLK		t _{DQSCK}	-0.75	0.75	-0.8	0.8	ns	
DQS-DQ skew (for DQS and associated DQ signals)		t _{DQSQ}	-0.5	0.5	-0.6	0.6	ns	
DQS-DQ skew (for DQS and all DQ signals)		t _{DQSQA}	-0.5	0.5	-0.6	0.6	ns	
Data out low-impedance time from CLK, /CLK		t _{LZ}	-0.75	0.75	-0.8	0.8	ns	
Data out high-impedance time from CLK, /CLK		t _{HZ}	-0.75	0.75	-0.8	0.8	ns	
Half clock period		t _{HP}	t _{CH} , t _{CL}		t _{CH} , t _{CL}		ns	
DQS read preamble		t _{RPRE}	0.9	1.1	0.9	1.1	t _{CK}	
DQS read postamble		t _{RPST}	0.4	0.6	0.4	0.6	t _{CK}	
DQ-DQS hold, DQS to first DQ to go non-valid, per access		t _{QH}	t _{HP} - 0.75		t _{HP} - 1		ns	
DQ and DM input setup time		t _{DS}	0.5		0.6		ns	
DQ and DM input hold time		t _{DH}	0.5		0.6		ns	
DQ and DM input pulse width (for each input)		t _{DIPW}	1.75		2		ns	
DQS write preamble setup time		t _{WPRES}	0		0		ns	
DQS write preamble		t _{WPRE}	0.25		0.25		t _{CK}	
Write postamble		t _{WPST}	0.4	0.6	0.4	0.6	t _{CK}	
Write command to first DQS latching transition		t _{DQSS}	0.75	1.25	0.75	1.25	t _{CK}	
DQS input high pulse width		t _{DQSH}	0.35		0.35		t _{CK}	
DQS input low pulse width		t _{DQSL}	0.35		0.35		t _{CK}	
DQS falling edge to CLK setup time		t _{DSS}	0.2		0.2		t _{CK}	
DQS falling edge hold time from CLK		t _{DSH}	0.2		0.2		t _{CK}	
Address and control input setup time		t _{IS}	0.9		1.1		ns	
Address and control input hold time		t _{IH}	0.9		1.1		ns	
Address and control input pulse width		t _{IPW}	2.2		2.5		ns	
Internal write to read command delay		t _{WTR}	1		1		t _{CK}	

Remark These specifications are applied to the monolithic device.

Asynchronous Characteristics

Parameter	Symbol	-C75(PC266B)		-C80(PC200)		Unit
		MIN.	MAX.	MIN.	MAX.	
ACT to REF/ACT command period (operation)	t _{RC}	65		70		ns
REF to REF/ACT command period (refresh)	t _{RFC}	75		80		ns
ACT to PRE command period	t _{RAS}	45	120,000	50	120,000	ns
PRE to ACT command period	t _{RP}	20		20		ns
ACT to READ/WRITE delay	t _{RCD}	20		20		ns
ACT(one) to ACT(another) command period	t _{RRD}	15		15		ns
Write recovery time	t _{WR}	15		15		ns
Auto precharge write recovery time + precharge time	t _{DAL}	35		35		ns
Mode register set command cycle time	t _{MRD}	15		15		ns
Exit self refresh to command	t _{XSNR}	75		80		ns
Refresh time (4,096 refresh cycles)	t _{REF}		64		64	ms

Serial PD

(1/2)

Byte No.	Function Described	Hex	Bit 7	Bit 6	Bit 5	Bit 4	Bit 3	Bit 2	Bit 1	Bit 0	Notes	
0	Defines the number of bytes written into serial PD memory	80H	1	0	0	0	0	0	0	0	128 bytes	
1	Total number of bytes of serial PD memory	08H	0	0	0	0	1	0	0	0	256 bytes	
2	Fundamental memory type	07H	0	0	0	0	0	1	1	1	DDR SDRAM	
3	Number of rows	0CH	0	0	0	0	1	1	0	0	12 rows	
4	Number of columns	0AH	0	0	0	0	1	0	1	0	10 columns	
5	Number of banks	01H	0	0	0	0	0	0	0	1	1 bank	
6	Data width	48H	0	1	0	0	1	0	0	0	72 bits	
7	Data width (continued)	00H	0	0	0	0	0	0	0	0	0	
8	Voltage interface	04H	0	0	0	0	0	1	0	0	SSTL2	
9	CL = 2.5 Cycle time	-C75	75H	0	1	1	1	0	1	0	1	7.5 ns
		-C80	80H	1	0	0	0	0	0	0	0	8 ns
10	CL = 2.5 Access time	-C75	75H	0	1	1	1	0	1	0	1	0.75 ns
		-C80	80H	1	0	0	0	0	0	0	0	0.8 ns
11	DIMM configuration type	02H	0	0	0	0	0	0	1	0	ECC	
12	Refresh rate/type	80H	1	0	0	0	0	0	0	0	Normal	
13	SDRAM width	08H	0	0	0	0	1	0	0	0	x8	
14	Error checking SDRAM width	08H	0	0	0	0	1	0	0	0	x8	
15	Minimum clock delay	01H	0	0	0	0	0	0	0	1	1 clock	
16	Burst length supported	0EH	0	0	0	0	1	1	1	0	2, 4, 8	
17	Number of banks on each SDRAM	04H	0	0	0	0	0	1	0	0	4 banks	
18	/CAS latency supported	0CH	0	0	0	0	1	1	0	0	2.5	
19	/CS latency supported	01H	0	0	0	0	0	0	0	1	0	
20	/WE latency supported	02H	0	0	0	0	0	0	1	0	1	
21	SDRAM module attributes	26H	0	0	1	0	0	1	1	0	Reg.+PLLdifclk	
22	SDRAM device attributes : General	00H	0	0	0	0	0	0	0	0	V _{DD} ± 0.2 V	
23	CL = 2 Cycle time	-C75	A0H	1	0	1	0	0	0	0	0	10 ns
		-C80	A0H	1	0	1	0	0	0	0	0	10 ns
24	CL = 2 Access time	-C75	75H	0	1	1	1	0	1	0	1	0.75 ns
		-C80	80H	1	0	0	0	0	0	0	0	0.8 ns
25-26												
27	t _{RP(MIN.)}	-C75	50H	0	1	0	1	0	0	0	0	20 ns
		-C80	50H	0	1	0	1	0	0	0	0	20 ns
28	t _{R RD(MIN.)}	-C75	3CH	0	0	1	1	1	1	0	0	15 ns
		-C80	3CH	0	0	1	1	1	1	0	0	15 ns
29	t _{R CD(MIN.)}	-C75	50H	0	1	0	1	0	0	0	0	20 ns
		-C80	50H	0	1	0	1	0	0	0	0	20 ns
30	t _{R AS(MIN.)}	-C75	2DH	0	0	1	0	1	1	0	1	45 ns
		-C80	32H	0	0	1	1	0	0	1	0	50 ns
31	Module bank density	20H	0	0	1	0	0	0	0	0	128M bytes	

(2/2)

Byte No.	Function Described	Hex	Bit 7	Bit 6	Bit 5	Bit 4	Bit 3	Bit 2	Bit 1	Bit 0	Notes	
32	Command and address signal input setup time	C0H	1	1	0	0	0	0	0	0	1.1 ns	
33	Command and address signal input hold time	C0H	1	1	0	0	0	0	0	0	1.1 ns	
34	Data signal input setup time	60H	0	1	1	0	0	0	0	0	0.6 ns	
35	Data signal input hold time	60H	0	1	1	0	0	0	0	0	0.6 ns	
36-61												
62	SPD revision	00H	0	0	0	0	0	0	0	0		
63	Checksum for bytes 0 - 62	-C75	34H	0	0	1	1	0	1	0	0	
		-C80	5AH	0	1	0	1	1	0	1	0	
64-71	Manufacture's JEDEC ID code											
72	Manufacturing location											
73-90	Manufacture's P/N											
91	Revision Code											
93-94	Manufacturing date											
95-99	Assembly serial number											
100-125	Mfg specific	00H	0	0	0	0	0	0	0	0		
126	Intel specification frequency	C8H	1	1	0	0	1	0	0	0	200 MHz	
127	Intel specification /CAS latency support	-C75	00H	0	0	0	0	0	0	0		
		-C80	00H	0	0	0	0	0	0	0		

Timing Chart

Refer to the μ PD45D128442, 45D128842, 45D128164 Data sheet (M13852E).

Package Drawing

184-PIN DUAL IN-LINE MODULE (SOCKET TYPE)

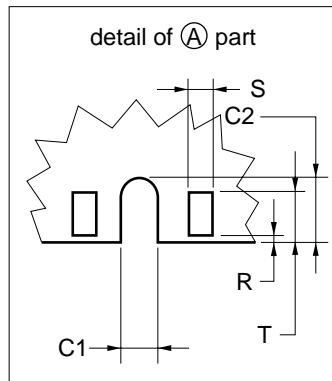
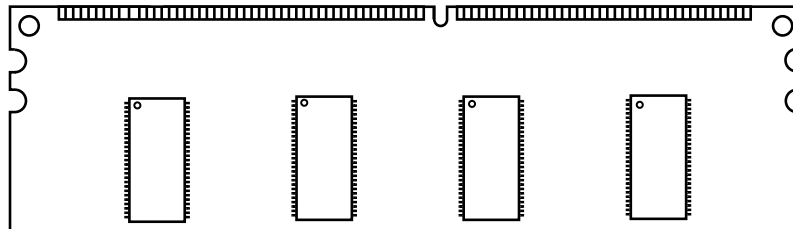
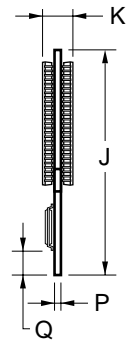
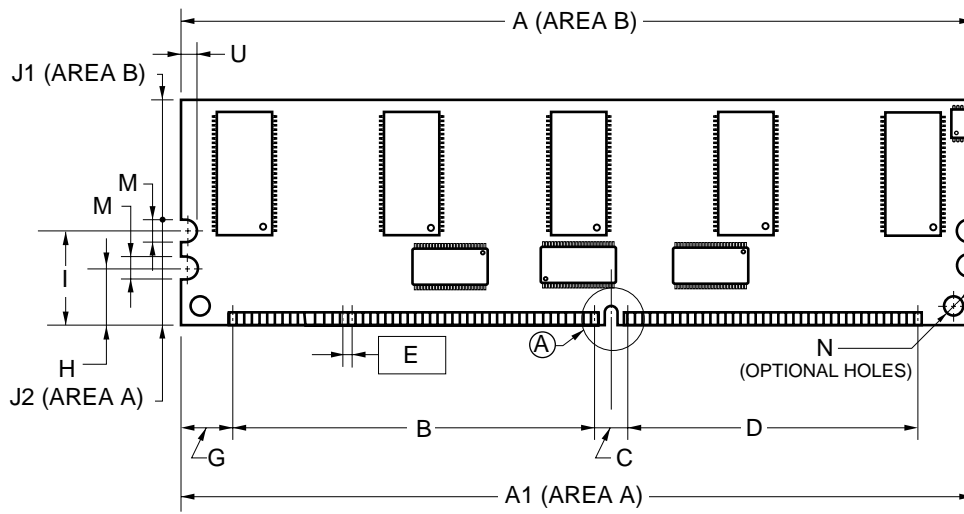

ITEM	MILLIMETERS
A	133.35
A1	133.35±0.13
B	64.77
C	6.35
C1	1.80
C2	3.80
D	49.53
E	1.27 (T.P.)
G	6.35
H	10.00
I	17.80
J	43.18±0.13
J1	23.38
J2	19.80
K	9.0 MAX.
M	4.0
N	φ 2.50
P	1.27±0.1
Q	4.0 MIN.
R	0.2±0.15
S	1.0±0.05
T	2.50±0.15
U	3.0 MIN.

[MEMO]

[MEMO]

NOTES FOR CMOS DEVICES**① PRECAUTION AGAINST ESD FOR SEMICONDUCTORS**

Note:

Strong electric field, when exposed to a MOS device, can cause destruction of the gate oxide and ultimately degrade the device operation. Steps must be taken to stop generation of static electricity as much as possible, and quickly dissipate it once, when it has occurred. Environmental control must be adequate. When it is dry, humidifier should be used. It is recommended to avoid using insulators that easily build static electricity. Semiconductor devices must be stored and transported in an anti-static container, static shielding bag or conductive material. All test and measurement tools including work bench and floor should be grounded. The operator should be grounded using wrist strap. Semiconductor devices must not be touched with bare hands. Similar precautions need to be taken for PW boards with semiconductor devices on it.

② HANDLING OF UNUSED INPUT PINS FOR CMOS

Note:

No connection for CMOS device inputs can be cause of malfunction. If no connection is provided to the input pins, it is possible that an internal input level may be generated due to noise, etc., hence causing malfunction. CMOS devices behave differently than Bipolar or NMOS devices. Input levels of CMOS devices must be fixed high or low by using a pull-up or pull-down circuitry. Each unused pin should be connected to V_{DD} or GND with a resistor, if it is considered to have a possibility of being an output pin. All handling related to the unused pins must be judged device by device and related specifications governing the devices.

③ STATUS BEFORE INITIALIZATION OF MOS DEVICES

Note:

Power-on does not necessarily define initial status of MOS device. Production process of MOS does not define the initial operation status of the device. Immediately after the power source is turned ON, the devices with reset function have not yet been initialized. Hence, power-on does not guarantee out-pin levels, I/O settings or contents of registers. Device is not initialized until the reset signal is received. Reset operation must be executed immediately after power-on for devices having reset function.

CAUTION FOR HANDLING MEMORY MODULES

When handling or inserting memory modules, be sure not to touch any components on the modules, such as the memory IC, chip capacitors and chip resistors. It is necessary to avoid undue mechanical stress on these components to prevent damaging them.

When re-packing memory modules, be sure the modules are NOT touching each other. Modules in contact with other modules may cause excessive mechanical stress, which may damage the modules.

- **The information in this document is subject to change without notice. Before using this document, please confirm that this is the latest version.**
 - No part of this document may be copied or reproduced in any form or by any means without the prior written consent of NEC Corporation. NEC Corporation assumes no responsibility for any errors which may appear in this document.
 - NEC Corporation does not assume any liability for infringement of patents, copyrights or other intellectual property rights of third parties by or arising from use of a device described herein or any other liability arising from use of such device. No license, either express, implied or otherwise, is granted under any patents, copyrights or other intellectual property rights of NEC Corporation or others.
 - Descriptions of circuits, software, and other related information in this document are provided for illustrative purposes in semiconductor product operation and application examples. The incorporation of these circuits, software, and information in the design of the customer's equipment shall be done under the full responsibility of the customer. NEC Corporation assumes no responsibility for any losses incurred by the customer or third parties arising from the use of these circuits, software, and information.
 - While NEC Corporation has been making continuous effort to enhance the reliability of its semiconductor devices, the possibility of defects cannot be eliminated entirely. To minimize risks of damage or injury to persons or property arising from a defect in an NEC semiconductor device, customers must incorporate sufficient safety measures in its design, such as redundancy, fire-containment, and anti-failure features.
 - NEC devices are classified into the following three quality grades:
"Standard", "Special", and "Specific". The Specific quality grade applies only to devices developed based on a customer designated "quality assurance program" for a specific application. The recommended applications of a device depend on its quality grade, as indicated below. Customers must check the quality grade of each device before using it in a particular application.
 - Standard: Computers, office equipment, communications equipment, test and measurement equipment, audio and visual equipment, home electronic appliances, machine tools, personal electronic equipment and industrial robots
 - Special: Transportation equipment (automobiles, trains, ships, etc.), traffic control systems, anti-disaster systems, anti-crime systems, safety equipment and medical equipment (not specifically designed for life support)
 - Specific: Aircraft, aerospace equipment, submersible repeaters, nuclear reactor control systems, life support systems or medical equipment for life support, etc.
- The quality grade of NEC devices is "Standard" unless otherwise specified in NEC's Data Sheets or Data Books. If customers intend to use NEC devices for applications other than those specified for Standard quality grade, they should contact an NEC sales representative in advance.