

556-1 Dual Timer

Product Specification

Military Linear Products

DESCRIPTION

The 556-1 Dual Monolithic timing circuit is a highly stable controller capable of producing accurate time delays or oscillation. The 556-1 is a dual 555. Timing is provided by an external resistor and capacitor for each timing function. The two timers operate independently of each other, sharing only V_{CC} and ground. The circuits may be triggered and reset on falling waveforms. The output structures may sink or source 200mA.

FEATURES

- Turn-off time less than $2\mu s$
- Max. operating frequency greater than 500kHz
- Timing from microseconds to hours
- Replaces two 555 timers
- Operates in both astable and monostable modes

- High output current
- Adjustable duty cycle
- TTL compatible
- Temperature stability of 0.005% per $^{\circ}C$

APPLICATIONS

- Precision timing
- Sequential timing
- Pulse shaping
- Pulse generator
- Missing pulse detector
- Tone burst generator
- Pulse width modulation
- Time delay generator
- Frequency division
- Pulse position modulation
- Touch tone encoder

PIN CONFIGURATION

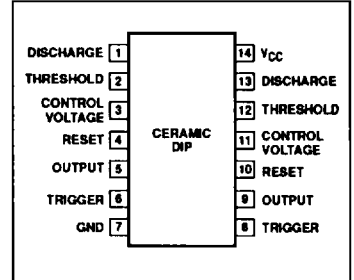

ORDERING INFORMATION

DESCRIPTION	ORDER CODE
14-Pin Ceramic DIP	556-1/BCA

BLOCK DIAGRAM

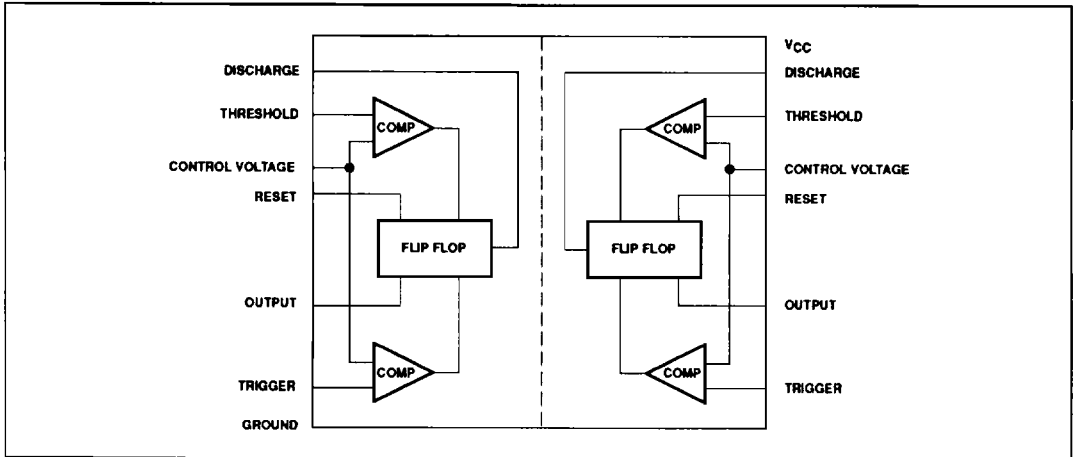

® Touch-Tone is a registered trademark of AT&T

Dual Timer

556-1

EQUIVALENT SCHEMATIC (Shown for One Circuit Only)

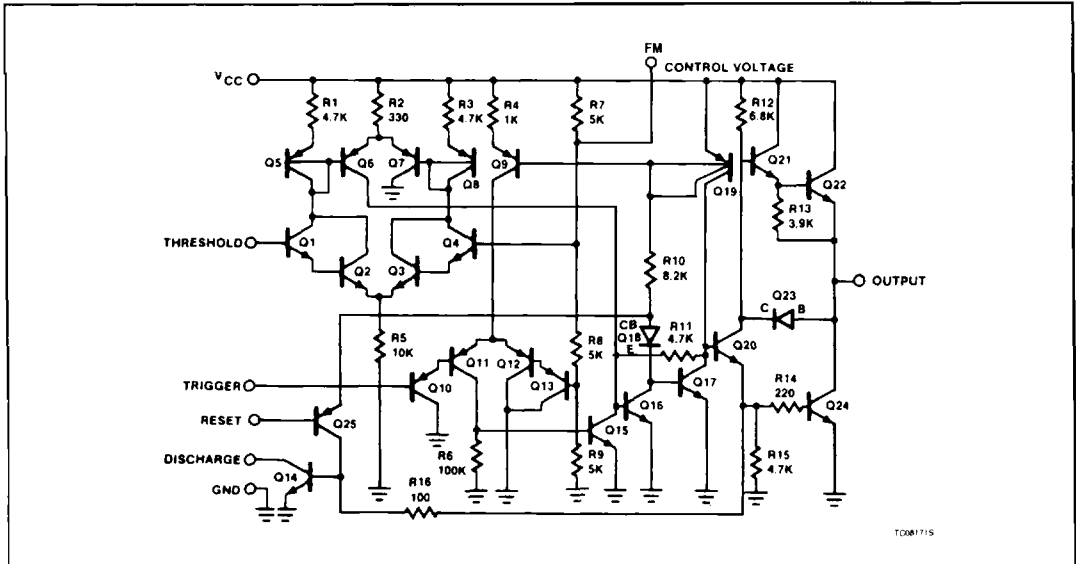

ABSOLUTE MAXIMUM RATINGS

SYMBOL	PARAMETER	RATING ¹	UNIT
V _{CC}	Supply voltage	+18	V
P _D	Power dissipation	600	mW
T _{STG}	Storage temperature range	-65 to +150	°C

Dual Timer

556-1

DC ELECTRICAL CHARACTERISTICS $T_A = 25^\circ\text{C}$, $V_{CC} = +5\text{V}$ to $+15\text{V}$, unless otherwise specified.

SYMBOL	PARAMETER	TEST CONDITIONS	$T_A = +25^\circ\text{C}$			$T_A = -55^\circ\text{C}, +125^\circ\text{C}$			UNIT
			Min	Typ	Max	Min	Typ	Max	
V_{CC}	Supply voltage		4.5		18	4.5		18	V
I_{CC}	Supply current (low state) ²	$V_{CC} = +5\text{V}, R_L = \infty$ $V_{CC} = +15\text{V}, R_L = \infty$		6 20	10 24			12 28	mA mA
t_M $\Delta t_M/\Delta T$ $\Delta t_M/\Delta V_S$	Timing error (monostable) Initial accuracy ³ Drift with temperature ^{7,10} Drift with supply voltage	$R_A = 2\text{K}\Omega$ to $100\text{K}\Omega$ $C = 0.1\mu\text{F}$ $T = 1.1 RC$		0.5 0.05	2.0 0.2			2.5 100 0.25	% ppm/ $^\circ\text{C}$ %/V
t_A $\Delta t_A/\Delta T$ $\Delta t_A/\Delta V_S$	Timing error (astable) Initial accuracy ³ Drift with temperature ⁷ Drift with supply voltage ⁹	$R_A, R_B = 1\text{K}\Omega$ to $100\text{K}\Omega$ $C = 0.1\mu\text{F}$ $V_{CC} = +15\text{V}$		4 0.15	6 0.6			10 500 1.5	% ppm/ $^\circ\text{C}$ %/V
V_C	Control voltage level	$V_{CC} = +15\text{V}$ $V_{CC} = +5\text{V}$	9.6 2.9	10.0 3.33	10.4 3.8	9.6 2.9		10.4 3.8	V V
V_{TH}	Threshold voltage	$V_{CC} = +15\text{V}$ $V_{CC} = +5\text{V}$	9.4 2.7	10.0 3.33	10.6 4.0	9.4 2.7		10.6 4.0	V V
I_{TH}	Threshold current ⁴	$V_{TH} = 10.6\text{V}$		0.03	0.25			0.35	μA
V_{TRIG}	Trigger voltage	$V_{CC} = +15\text{V}$ $V_{CC} = +5\text{V}$	4.8 1.45	5.0 1.67	5.2 1.9	4.5 1.5		5.5 2.2	V V
I_{TRIG}	Trigger current	$V_{TRIG} = 0\text{V}$		0.5	0.9			2.0	μA
V_{RESET} I_{RESET}	Reset voltage ⁵ Reset current	$V_{RESET} = 0.4\text{V}$	0.4	0.7 -0.1	1.0 -0.4	0.1		1.3 -1.6	V mA
V_{OL}	Output voltage (low)	$V_{CC} = +15\text{V}$ $I_{SINK} = 10\text{mA}$ $I_{SINK} = 50\text{mA}$ $I_{SINK} = 100\text{mA}$		0.1 0.4 0.8	0.15 0.5 1.2			0.25 0.70 1.6	V V V
V_{OL}	Output voltage (low)	$V_{CC} = +5\text{V}$ $I_{SINK} = 8\text{mA}$ $I_{SINK} = 5\text{mA}$		0.1 0.05	0.2 0.15			0.30 0.20	V V
V_{OH}	Output voltage (high)	$V_{CC} = +15\text{V}$ $I_{SOURCE} = -100\text{mA}$ $V_{CC} = +5\text{V}$ $I_{SOURCE} = -100\text{mA}$	13.0 3.0	13.3 3.3		12.5 2.6			V V
I_D	Discharge leakage current			20	100			500	nA
Δt_D $\Delta t_D/\Delta T$ $\Delta t_D/\Delta V_S$	Matching characteristics ^{7, 8} Initial accuracy ^{3, 7} Drift with temperature ⁷ Drift with supply voltage ⁷			0.5 0.1	1.0 0.2		10		% ppm/ $^\circ\text{C}$ %/V

Dual Timer

556-1

AC ELECTRICAL CHARACTERISTICS $V_{CC} = +5V$ to $+15V$, unless otherwise specified.

SYMBOL	PARAMETER	TEST CONDITIONS	$T_A = +25^\circ C$			$T_A = -55^\circ C, +125^\circ C$			UNIT
			Min	Typ	Max	Min	Typ	Max	
t_{OFF}	Turn-off time ^{6, 7}	$V_{RESET} = V_{CC}$		0.5	2.0				μs
t_R	Rise time of output ⁷			100	200				ns
t_F	Fall time of output ⁷			100	200				ns

NOTES:

1. Operation beyond the limits in this table may impair the useful life of the device.
2. Supply current when output is high is typically 1.0mA less.
3. Tested at $V_{CC} = 5V$ and $V_{CC} = 15V$.
4. This will determine the max value of $R_A + R_B$. For 15V operation, the max total $R = 10M\Omega$, and for 5V operation, the max total $R = 3.4m\Omega$.
5. Specified with trigger input high.
6. Time measured from a positive going input pulse from 0 to 0.4 V_{CC} into the threshold to the drop from high to low of the output. Trigger is tied to threshold.
7. This parameter is guaranteed, but not tested.
8. Matching characteristics refer to the difference between performance characteristics for each timer section in the monostable mode.
9. Testing performed at $R_A = R_B = 100k\Omega$.
10. Testing performed at $R_A = 100k\Omega$ only.

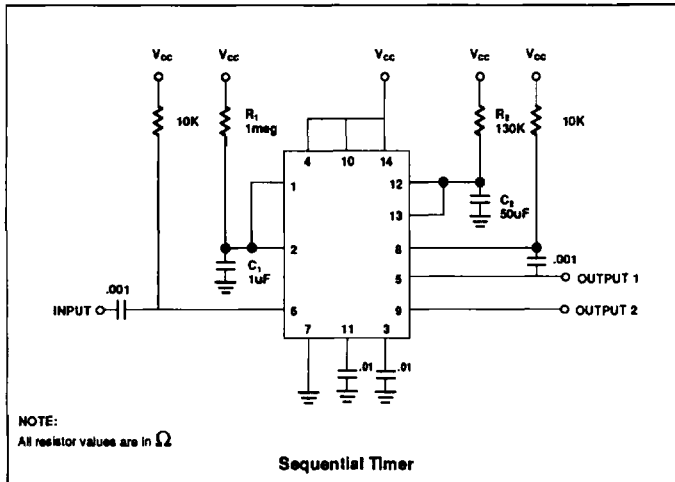

TYPICAL APPLICATIONS

One feature of the dual timer is that by utilizing both halves it is possible to obtain sequential timing. By connecting the output of the first half to the input of the second half via a 0.001 μ fd coupling capacitor sequential timing may be obtained. Delay t_1 is determined by the first half and t_2 by the second half delay.

The first half of the timer is started by momentarily connecting Pin 6 to ground. When it is timed out (determined by $1.1R_1C_1$) the second half begins. Its duration is determined by $1.1R_2C_2$.

Dual Timer

556-1

TYPICAL PERFORMANCE CHARACTERISTICS

