

**HIGH-SPEED POF/HPCF DATA LINK TRANSCEIVER MODULE
COMPLIANT WITH ATM FORUM SPECIFICATIONS**

DESCRIPTION

The NL2100 is a data link transceiver module for high-speed data transmission up to 156 Mb/s over 50 meters (POF) and 100 meters (HPCF), compliant with ATM Forum specifications. The transceiver contains a 650 nm LED transmitter and a PIN/preamplifier receiver. The package is a 1 × 9 industrial standard Single In-line Package (SIP).

The transceiver and Plastic Optical Fiber (POF)/Hard Polymer Clad Fiber (HPCF) provide cost effective solutions for 156 Mb/s ATM-LAN, 100 Mb/s Fast Ethernet, IEEE1394.b s100 (long distance) and other high-speed data transmission systems.

FEATURES

- Data rate 1 to 156 Mb/s
- Transmission distance up to 50 meters (SI-POF), up to 100 meters (SI-HPCF)
- 1 × 9 industry standard SIP
- +5 V single voltage power supply
- Differential PECL interface
- F07 (PN type) connector

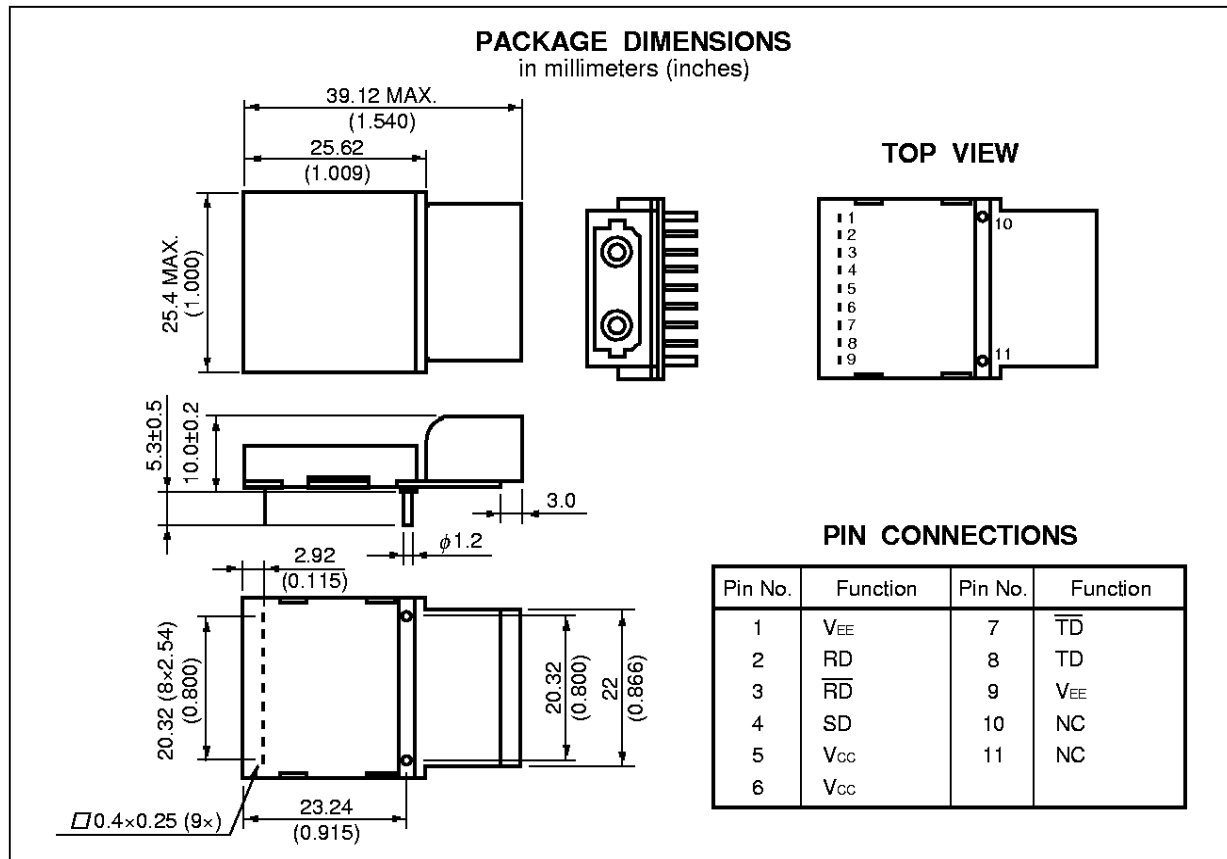

The information in this document is subject to change without notice.

ABSOLUTE MAXIMUM RATINGS (T_c = 25 °C, unless otherwise specified)

Parameter	Symbol	Ratings	Unit
Operating Case Temperature	T _c	0 to +70	°C
Storage Temperature	T _{stg}	-40 to +85	°C
Supply Voltage	V _{cc}	-0.5 to +7.0	V
★ Input Voltage	V _i	-0.5 to V _{cc} +0.5	V

RECOMMENDED OPERATING CONDITIONS

Parameter	Symbol	MIN.	TYP.	MAX.	Unit
Supply Voltage	V _{cc}	4.75	5.00	5.25	V
Fiber	SI-POF, SI-HPCF				

ELECTRO-OPTICAL CHARACTERISTICS (T_c = 25 °C)

Parameter	Symbol	Conditions	MIN.	TYP.	MAX.	Unit
Transmission Speed	—		1		156	Mb/s
Transmission Distance	—	SI-POF, 2 connection points			50	m
		SI-HPCF, 2 connection points			100	
★ Fiber Launched Power	P _o	SI-POF (50 cm)	-8	-4	-2	dBm
		SI-HPCF (50 cm)	-20	-17	-14	
Center Wavelength	λ _c		640	650	660	nm
Spectral Width	Δλ				40	nm
Rise Time	t _r	10 to 90%			4.5	ns
Fall Time	t _f	90 to 10%			4.5	ns
Extinction Ratio	E _x		10			dB
★ Overload	—	BER = 10 ⁻¹⁰ , SI-POF (156 Mb/s, NRZ, 2 ²³ -1PRBS, mark density 1/2)	-2			dBm
		BER = 10 ⁻¹⁰ , SI-HPCF (156 Mb/s, NRZ, 2 ²³ -1PRBS, mark density 1/2)	-14			
★ Receiver Sensitivity	P _{in}	BER = 10 ⁻¹⁰ , SI-POF (156 Mb/s, NRZ, 2 ²³ -1PRBS, mark density 1/2)		-26	-25	dBm
		BER = 10 ⁻¹⁰ , SI-HPCF (156 Mb/s, NRZ, 2 ²³ -1PRBS, mark density 1/2)		-27.5	-26.5	
Dynamic Range	P			25		dB
Signal Detect Level	P _{SD}			-30		dBm
★ Circuit Current	I _{CC}	156 Mb/s, NRZ, 2 ²³ -1PRBS, mark density 1/2		175		mA
Data Input Voltage (High)	V _{IL} - V _{CC}	(TD, $\overline{\text{TD}}$ pin)	-1.165		-0.880	V
★ Data Input Voltage (Low)	V _{IH} - V _{CC}	(TD, $\overline{\text{TD}}$ pin)	-1.810		-1.475	V
Data Output Voltage (High)	V _{OL} - V _{CC}	(RD, $\overline{\text{RD}}$, SD pin)	-1.100		-0.880	V
★ Data Output Voltage (Low)	V _{OH} - V _{CC}	(RD, $\overline{\text{RD}}$, SD pin)	-1.840		-1.620	V

RECOMMENDED OPTICAL FIBERS AND CONNECTORS (as of June 1998)

Components	Manufacturer	Product Type
SI-POF	ASAHI CHEMICAL INDUSTRY	AC-1000W
	MITSUBISHI RAYON	MH-4002
	Toray Industries	PMU-CD1002-22-E
SI-HPCF	SUMITOMO ELECTRIC INDUSTRIES	DCL-HA-20/1010
	Toray Industries	HMU-CD202-22-V
Connector for POF	AMP	353375-2
	Molex	53844-0211
Connector for HPCF	SUMITOMO ELECTRIC INDUSTRIES	CF2071

BLOCK DIAGRAM

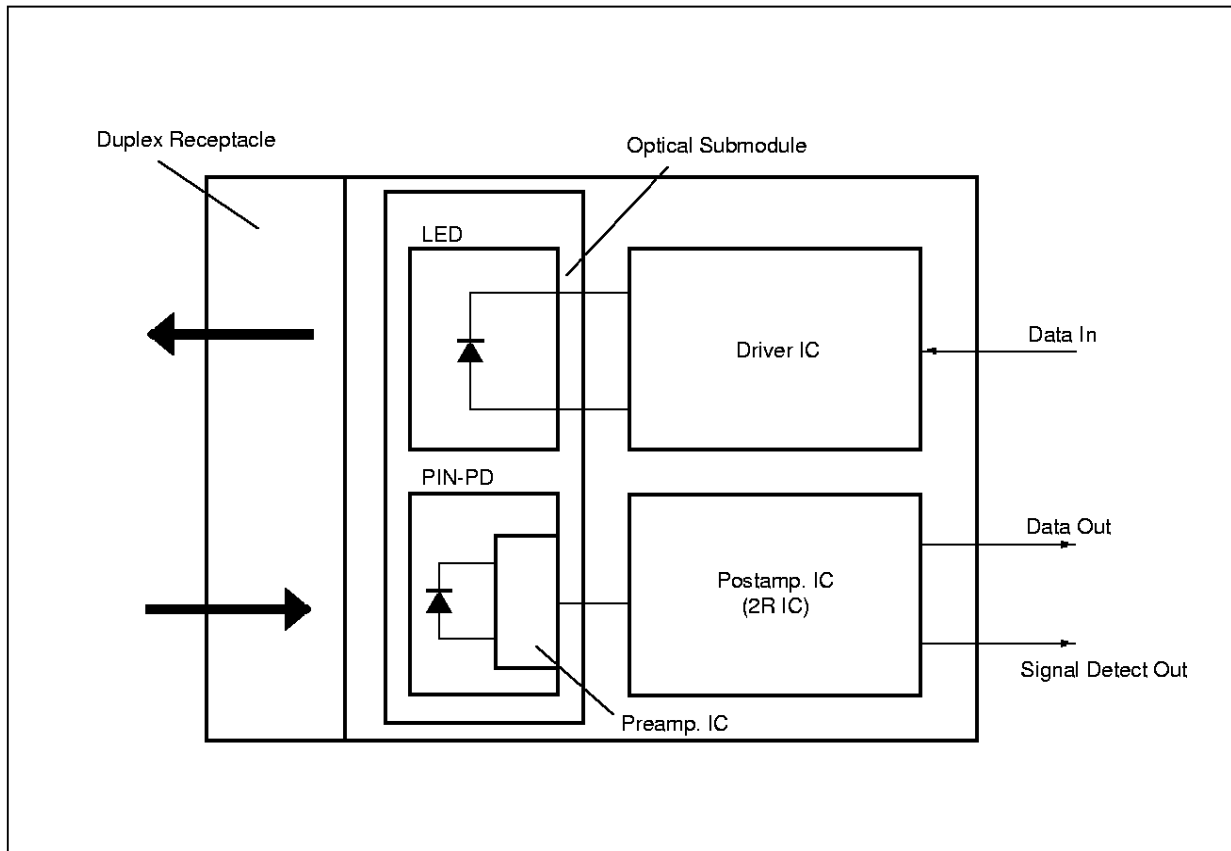

★ HANDLING CAUTION

- (1) Ripple noise shall not be touched on Vcc and Ground. Applicable condenser shall be inserted between Vcc and Ground.
- (2) Lead Soldering Condition (Handling iron)
It shall be done more than 1.6 mm from the root of the lead for 260 °C or below, 10 sec. or below.
- (3) Cleansing
Cleansing may damage the device.

REFERENCE

Document Name	Document No.
NEC semiconductor device reliability/quality control system	C11159E
Quality grades on NEC semiconductor devices	C11531E
Semiconductor device mounting technology manual	C10535E

[MEMO]

CAUTION

Within this device there exists GaAs (Gallium Arsenide) material which is a harmful substance if ingested. Please do not under any circumstances break the package.

The export of this product from Japan is prohibited without governmental license. To export or re-export this product from a country other than Japan may also be prohibited without a license from that country. Please call an NEC sales representative.

No part of this document may be copied or reproduced in any form or by any means without the prior written consent of NEC Corporation. NEC Corporation assumes no responsibility for any errors which may appear in this document.

NEC Corporation does not assume any liability for infringement of patents, copyrights or other intellectual property rights of third parties by or arising from use of a device described herein or any other liability arising from use of such device. No license, either express, implied or otherwise, is granted under any patents, copyrights or other intellectual property rights of NEC Corporation or others.

While NEC Corporation has been making continuous effort to enhance the reliability of its semiconductor devices, the possibility of defects cannot be eliminated entirely. To minimize risks of damage or injury to persons or property arising from a defect in an NEC semiconductor device, customers must incorporate sufficient safety measures in its design, such as redundancy, fire-containment, and anti-failure features.

NEC devices are classified into the following three quality grades:

"Standard", "Special", and "Specific". The Specific quality grade applies only to devices developed based on a customer designated "quality assurance program" for a specific application. The recommended applications of a device depend on its quality grade, as indicated below. Customers must check the quality grade of each device before using it in a particular application.

Standard: Computers, office equipment, communications equipment, test and measurement equipment, audio and visual equipment, home electronic appliances, machine tools, personal electronic equipment and industrial robots

Special: Transportation equipment (automobiles, trains, ships, etc.), traffic control systems, anti-disaster systems, anti-crime systems, safety equipment and medical equipment (not specifically designed for life support)

Specific: Aircrafts, aerospace equipment, submersible repeaters, nuclear reactor control systems, life support systems or medical equipment for life support, etc.

The quality grade of NEC devices is "Standard" unless otherwise specified in NEC's Data Sheets or Data Books. If customers intend to use NEC devices for applications other than those specified for Standard quality grade, they should contact an NEC sales representative in advance.

Anti-radioactive design is not implemented in this product.