

NOTES: UNLESS OTHERWISE SPECIFIED

1. MATERIAL SPECIFICATIONS:
BRASS PER ASTM B16
2. FINISH SPECIFICATIONS:
0.000030 MIN. GOLD PER SAE-AMS2422 OVER
0.000080 MIN. NICKEL PER SAE-AMS-QQ-N-290
3. FOR USE WITH 12 GA. EVERTOP UL1015 WIRE.

REV	DESCRIPTION	BY DATE	APPD
00	PRELIMINARY DRAWING	LMD 3/6/06	XXX

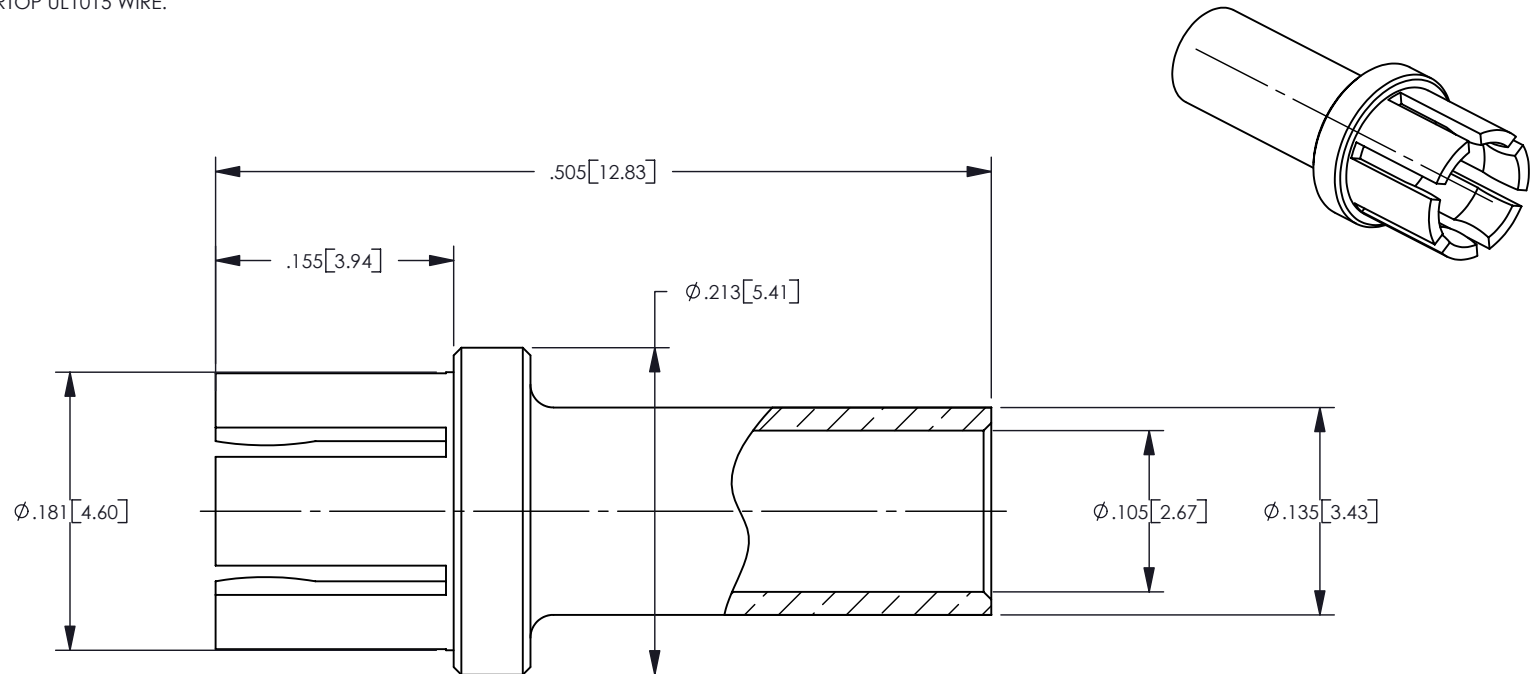

CATALOG P/N: 01384

PER ASME Y14.5M-1994
UNLESS OTHERWISE SPECIFIED:
DIMENSIONS ARE IN INCHES [MM]
TOLERANCES:
DECIMAL: .XX ± .01 [0.3]
.XXX ± .005 [0.13]
.XXXX ± .XXXX
ANGLES: ± 2° SCALE: 8:1

NORTHROP GRUMMAN
Winchester Electronics 62 Barnes Industrial Road North
Wallingford, CT 06492

DRAWN		DATE		APPROVED		DATE	
LMD		3/6/06		XXX		XX/XX/XX	
APPROVED		DATE		APPROVED		DATE	
XXX		XX/XX/XX		XXX		XX/XX/XX	

CUSTOMER DRAWING		STRIGHT FEMALE CRIMP CONTACT	
A	SDSD01384	SHT 1 OF 1	REV 00