

HITACHI

KAOHSIUNG HITACHI ELECTRONICS CO., LTD.

FOR MESSRS: _____

DATE: Apr. 07th 2010

CUSTOMER'S ACCEPTANCE SPECIFICATION

TX20D28VM2BAB

Contents

No.	ITEM	SHEET No.	PAGE
1	COVER	7B64PS 2701-TX20D28VM2BAB-2	1-1/1
2	RECORD OF REVISION	7B64PS 2702-TX20D28VM2BAB-2	2-1/1
3	GENERAL DATA	7B64PS 2703-TX20D28VM2BAB-2	3-1/1
4	ABSOLUTE MAXIMUM RATINGS	7B64PS 2704-TX20D28VM2BAB-2	4-1/1
5	ELECTRICAL CHARACTERISTICS	7B64PS 2705-TX20D28VM2BAB-2	5-1/2~2/2
6	OPTICAL CHARACTERISTICS	7B64PS 2706-TX20D28VM2BAB-2	6-1/2~2/2
7	BLOCK DIAGRAM	7B64PS 2707-TX20D28VM2BAB-2	7-1/1
8	RELIABILITY TESTS	7B64PS 2708-TX20D28VM2BAB-2	8-1/1
9	LCD INTERFACE	7B64PS 2709-TX20D28VM2BAB-2	9-1/7~7/7
10	OUTLINE DIMENSIONS	7B64PS 2710-TX20D28VM2BAB-2	10-1/2~2/2
11	APPEARANCE STANDARD	7B64PS 2711-TX20D28VM2BAB-2	11-1/3~3/3
12	PRECAUTIONS	7B64PS 2712-TX20D28VM2BAB-2	12-1/2~2/2
13	DESIGNATION OF LOT MARK	7B64PS 2713-TX20D28VM2BAB-2	13-1/1

ACCEPTED BY: _____

PROPOSED BY: Ken Chen

2. RECORD OF REVISION

DATE	SHEET No.	SUMMARY											
Apr.07,'10	7B64PS 2705 – TX20D28VM2BAB-2 Page 5-1/1	5.2 BACKLIGHT CHARACTERISTICS Added Note 3											
	7B64PS 2709 – TX20D28VM2BAB-2 Page 9-1/1	9.1 INTERFACE PIN CONNECTIONS Change <table border="1" style="margin: 5px 0; width: 100%; border-collapse: collapse;"> <thead> <tr> <th style="width: 25%;">Pin No.</th> <th style="width: 25%;">Symbol</th> <th style="width: 50%;">Signal</th> </tr> </thead> <tbody> <tr> <td style="text-align: center;">20</td> <td style="text-align: center;">NC</td> <td style="text-align: center;">No Connection</td> </tr> </tbody> </table> <div style="text-align: center; margin: 5px 0;">↓</div> <table border="1" style="margin: 5px 0; width: 100%; border-collapse: collapse;"> <thead> <tr> <th style="width: 25%;">Pin No.</th> <th style="width: 25%;">Symbol</th> <th style="width: 50%;">Signal</th> </tr> </thead> <tbody> <tr> <td style="text-align: center;">20</td> <td style="text-align: center;">TP</td> <td style="text-align: center;">Note 2</td> </tr> </tbody> </table> Added Note 2	Pin No.	Symbol	Signal	20	NC	No Connection	Pin No.	Symbol	Signal	20	TP
Pin No.	Symbol	Signal											
20	NC	No Connection											
Pin No.	Symbol	Signal											
20	TP	Note 2											

3. GENERAL DATA

3.1 DISPLAY FEATURES

This module is a 8.0" WVGA of 16:9 format amorphous silicon TFT. The pixel format is vertical stripe and sub pixels are arranged as R (red), G (green), B (blue) sequentially. This display is RoHS compliant, and COG (chip on glass) technology and LED backlight are applied on this display.

Part Name	TX20D28VM2BAB
Module Dimensions	189.0(W) mm x 120.0(H) mm x 7.5(D) mm typ.
LCD Active Area	174.0(W) mm x 104.4(H) mm
Dot Pitch	0.0725(W) mm x 3(R, G, B)(W) x 0.2175(H) mm
Resolution	800 x 3(RGB)(W) x 480(H) dots
Color Pixel Arrangement	R, G, B Vertical stripe
LCD Type	Transmissive Color TFT; Normally White
Display Type	Active Matrix
Number of Colors	262k Colors
Backlight	LED (Lifetime: 40 Khr)
Weight	170g typ.
Interface	LVDS; 20 pins
Power Supply Voltage	3.3V for LCD; 12V for Backlight
Power Consumption	1.0W for LCD; 2.45W for backlight
Viewing Direction	12 O'clock (without image inversion and least brightness change) 6 O'clock (contrast peak located at)

4. ABSOLUTE MAXIMUM RATINGS

Item	Symbol	Min.	Max.	Unit	Remarks
Supply Voltage	VDD	-0.3	4.0	V	-
Input Voltage of Logic	VI	-0.2	VDD+0.3	V	Note 1
Operating Temperature	Top	-20	70	°C	Note 2
Storage Temperature	Tst	-30	80	°C	Note 2

Note 1: The rating is defined for the signal voltages of the interface such as CLK and pixel data pairs.

Note 2: The maximum rating is defined as above based on the temperature on the panel surface, which might be different from ambient temperature after assembling the panel into the application. Moreover, some temperature-related phenomenon as below needed to be noticed:

- Background color, contrast and response time would be different in temperatures other than 25°C.
- Operating under high temperature will shorten LED lifetime.

5. ELECTRICAL CHARACTERISTICS

5.1 LCD CHARACTERISTICS

$T_a = 25\text{ }^\circ\text{C}$, $V_{SS} = 0\text{V}$

Item	Symbol	Condition	Min.	Typ.	Max.	Unit	Remarks
Power Supply Voltage	VDD	-	3.0	3.3	3.6	V	-
Differential Input Voltage for LVDS Receiver Threshold	VI	VIH	-	-	+100	mV	Note 1
		VIL	-100	-	-		
Power Supply Current	IDD	VDD-VSS =3.3V	-	300	400	mA	Note 2,3
Vsync Frequency	f_v	-	-	60	75	Hz	Note 4
Hsync Frequency	f_H	-	29.7	31.6	36.7	KHz	
DCLK Frequency	f_{CLK}	-	25	33.3	40	MHz	

Note 1: VCM=+1.2V

VCM is common mode voltage of LVDS transmitter/receiver.

The input terminal of LVDS transmitter is terminated with 100Ω.

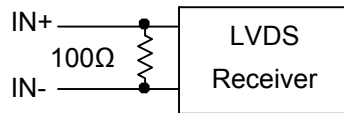

Note 2: An all black check pattern is used when measuring IDD, f_v is set to 60Hz.

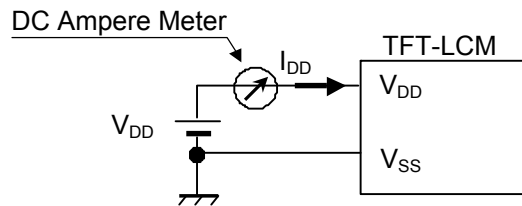

Note 3: 1.0A fuse is applied in the module for IDD. For display activation and protection purpose, power supply is recommended larger than 2.5A to start the display and break fuse once any short circuit occurred.

Note 4: For LVDS transmitter input.

5.2 BACKLIGHT CHARACTERISTICS

$T_a = 25\text{ }^\circ\text{C}$

Item	Symbol	Condition	Min.	Typ.	Max.	Unit	Remarks
LED Input Voltage	VLED	Backlight Unit	11.5	12.0	12.5	V	Note 1
LED Forward Current	ILED	Backlight Unit	-	204	209	mA	Note 1
LED Lifetime	-	204 mA	-	40K	-	hrs	Note 2,3

Note 1: The definitions of VLED and ILED are for the optical characteristic in section 6. Fig. 5.1 shows the LED backlight circuit including 51 LEDs and 249 ohm resistors.

Note 2: The estimated lifetime is specified as the time to reduce 50% brightness by applying 204 mA at 25°C.

Note 3: By applying different ILED, the estimated brightness and LED lifetime curves are shown as Fig 5.2 for various environment use. Do not apply ILED over 340mA for derating concern.

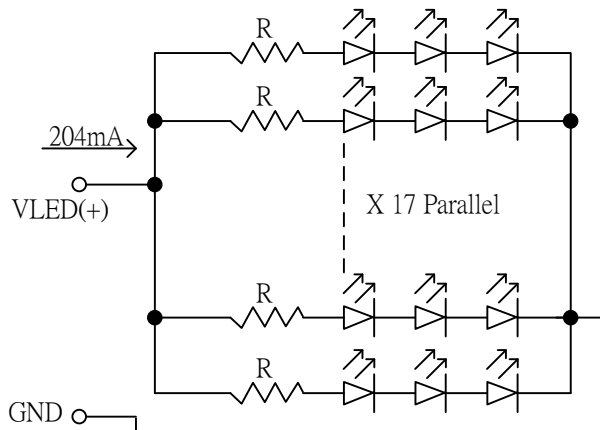

Fig 5.1

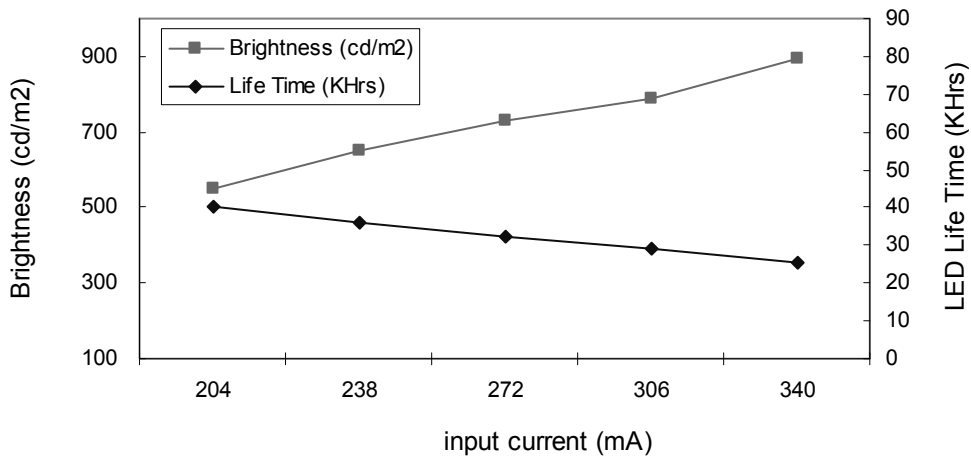

Fig 5.2

6. OPTICAL CHARACTERISTICS

The optical characteristics are measured based on the conditions as below:

- Supplying the signals and voltages defined in the section of electrical characteristics.
- The ambient temperature is 25 °C .
- In the dark room around 500~1000 lx, the equipment has been set for the measurements as shown in Fig 6.1.

$$T_a = 25\text{ }^{\circ}\text{C}, f_v = 60\text{ Hz}, VDD = 3.3\text{V}$$

Item	Symbol	Condition	Min.	Typ.	Max.	Unit	Remarks	
Brightness of White	-	$\phi = 0^{\circ}, \theta = 0^{\circ}$, ILED= 204 mA	440	550	-	cd/m ²	Note 1	
Brightness Uniformity	-		70	-	-	%	Note 2	
Contrast Ratio	CR		300	600	-	-	Note 3	
Response Time	Rise (Ton)	$\phi = 0^{\circ}, \theta = 0^{\circ}$	-	20	40	ms	Note 4	
	Fall (Toff)		-	10	20			
NTSC Ratio	-	$\phi = 0^{\circ}, \theta = 0^{\circ}$	-	60	-	%	-	
Viewing Angle	θ_x	$\phi = 0^{\circ}, CR \geq 10$	60	80	-	Degree	Note 5	
	$\theta_{x'}$	$\phi = 180^{\circ}, CR \geq 10$	60	80	-			
	θ_y	$\phi = 90^{\circ}, CR \geq 10$	50	60	-			
	$\theta_{y'}$	$\phi = 270^{\circ}, CR \geq 10$	70	80	-			
Color Chromaticity	Red	X	$\phi = 0^{\circ}, \theta = 0^{\circ}$	0.57	0.62	0.67	-	Note 6
		Y		0.31	0.36	0.41		
	Green	X		0.30	0.35	0.40		
		Y		0.56	0.61	0.66		
	Blue	X		0.10	0.15	0.20		
		Y		0.03	0.08	0.13		
	White	X		0.29	0.34	0.39		
		Y		0.31	0.36	0.41		

Note 1: The brightness is measured from center point of the panel, P5 in Fig. 6.2, for the typical value.

Note 2: The brightness uniformity is calculated by the equation as below:

$$\text{Brightness uniformity} = \frac{\text{Min. Brightness}}{\text{Max. Brightness}} \times 100\%$$

, which is based on the brightness values of the 9 points measured by BM-5 as shown in Fig. 6.2.

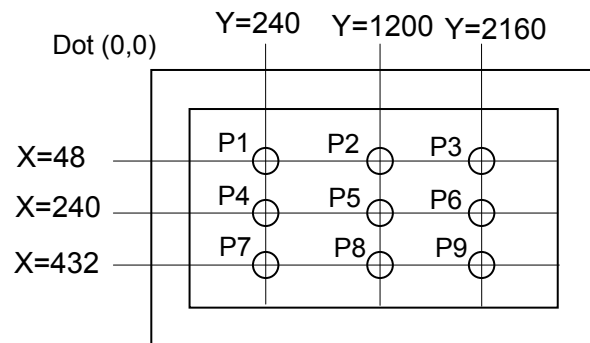
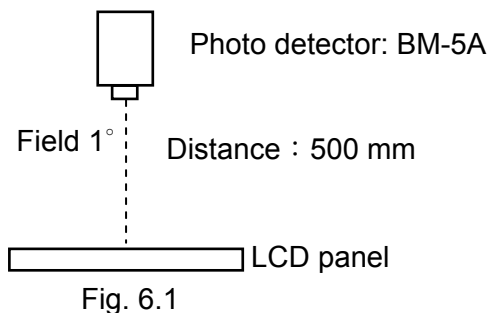

Note 3: The Contrast ratio is measured from the center point of the panel, P5, and defined as the following equation:

$$CR = \frac{\text{Brightness of White}}{\text{Brightness of Black}}$$

Note 4: The definition of response time is shown in Fig. 6.3. The rising time is the period from 90% brightness to 10% brightness when the data is from white to black. Oppositely, falling time is the period from 10% brightness rising to 90% brightness.

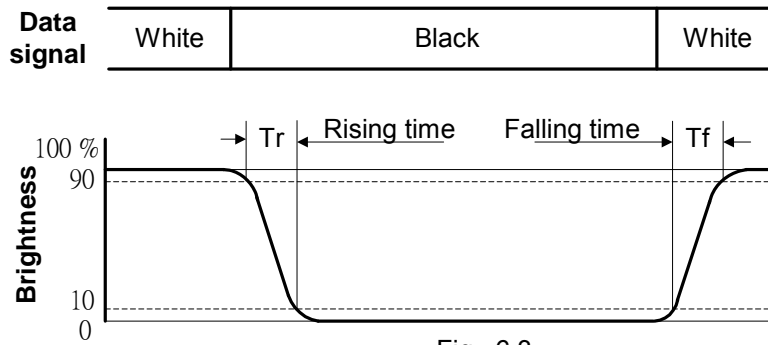

Fig . 6.3

Note 5: The definition of viewing angle is shown in Fig. 6.4. Angle ϕ is used to represent viewing directions, for instance, $\phi = 270^\circ$ means 6 o'clock, and $\phi = 0^\circ$ means 3 o'clock. Moreover, angle θ is used to represent viewing angles from axis Z toward plane XY.

The viewing direction of this display is 12 o'clock, which means that a photograph with gray scale would not be reversed in color and the brightness change would be less from this direction. However, the best contrast peak would be located at 6 o'clock.

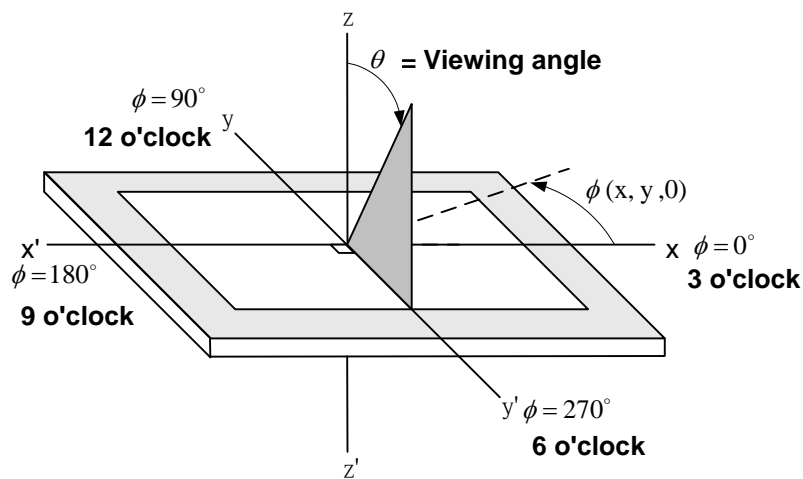
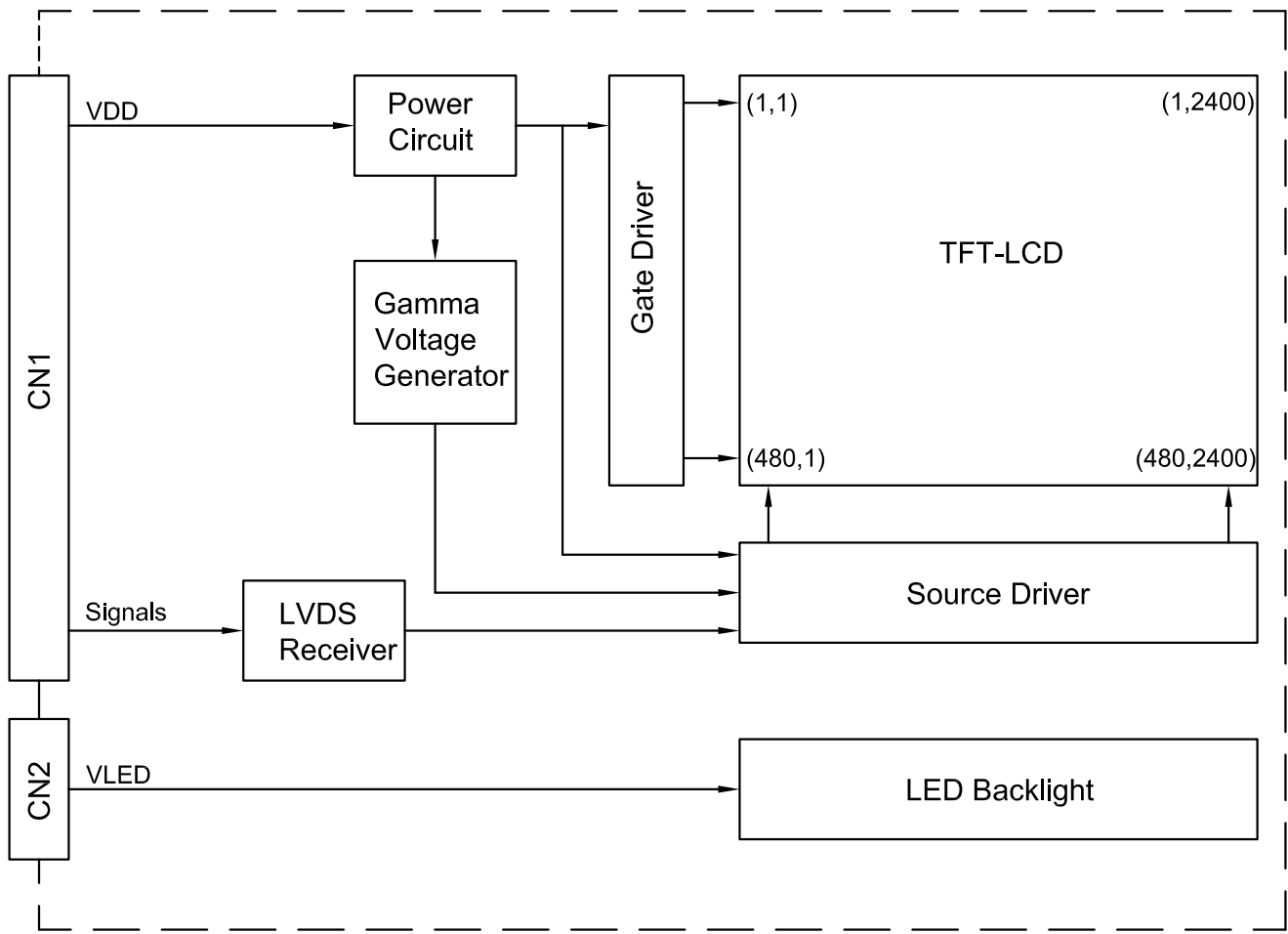

Fig. 6.4

Note 6: The color chromaticity is measured from the center point of the panel, P5, as shown in Fig. 6.2.

7. BLOCK DIAGRAM



Note: Signals are CLK, and pixel data pairs.

8. RELIABILITY TESTS

Test Item	Condition	
High Temperature	1) Operating 2) 70 °C	240 hrs
Low Temperature	1) Operating 2) -20 °C	240 hrs
High Temperature	1) Storage 2) 80 °C	240 hrs
Low Temperature	1) Storage 2) -30 °C	240 hrs
Heat Cycle	1) Operating 2) -20 °C ~70 °C 3) 3hrs~1hr~3hrs	240 hrs
Thermal Shock	1) Non-Operating 2) -35 °C ↔ 85 °C 3) 0.5 hr ↔ 0.5 hr	240 hrs
High Temperature & Humidity	1) Operating 2) 40 °C & 85%RH 3) Without condensation 4) Note 4	240 hrs
Vibration	1) Non-Operating 2) 20~50 Hz 3) 2G 4) X, Y, and Z directions	1 hr for each direction
Mechanical Shock	1) Non-Operating 2) 10 ms 3) 50G 4) ±X, ±Y and ±Z directions	Once for each direction
ESD	1) Operating 2) Tip: 200 pF, 250 Ω 3) Air discharge for glass: ± 8KV 4) Contact discharge for metal frame: ± 8KV	1) Glass: 9 points 2) Metal frame: 8 points

Note 1: Display functionalities are inspected under the conditions defined in the specification after the reliability tests.

Note 2: The display is not guaranteed for use in corrosive gas environments.

Note 3: All pins of LCD interface (CN1) have been tested by ± 100V contact discharge of ESD under non-operating condition.

Note 4: Under the condition of high temperature & humidity, if the temperature is higher than 40°C, the humidity needs to be reduced as Fig. 8.1 shown.

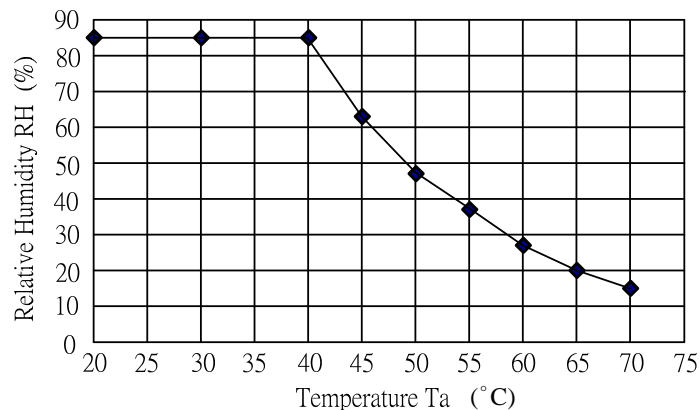

Fig. 8.1

9. LCD INTERFACE

9.1 INTERFACE PIN CONNECTIONS

The display interface connector (CN1) is FI-SEB20P-HF13E-E1500 made by JAE and pin assignment is as below:

Pin No.	Symbol	Signal	Pin No.	Symbol	Signal
1	VDD	Power Supply for Logic	11	IN2-	B2~B5, DE
2	VDD		12	IN2+	
3	VSS	GND	13	VSS	GND
4	VSS		14	CLK IN-	Pixel Clock
5	IN0-	R0~R5, G0	15	CLK IN+	
6	IN0+		16	VSS	GND
7	VSS	GND	17	NC	No Connection
8	IN1-	G1~G5, B0~B1	18	NC	No Connection
9	IN1+		19	NC	No Connection
10	VSS	GND	20	TP	Note 2

Note 1: IN n- and IN n+ (n=0, 1, 2), CLK IN- and CLK IN+ should be wired by twist-pairs or side-by-side FPC patterns, respectively.

Note 2: Pin 20 is for internal test only, please keep it open.

The backlight interface connector (CN2) is BHR-03VS-1 made by JST, and pin assignment is as below:

Pin No.	Signal	Level	Function
1	V _{LED+}	-	Power Supply for LED
2	NC	-	No Connection
3	V _{LED-}	-	GND

9.2 LVDS INTERFACE

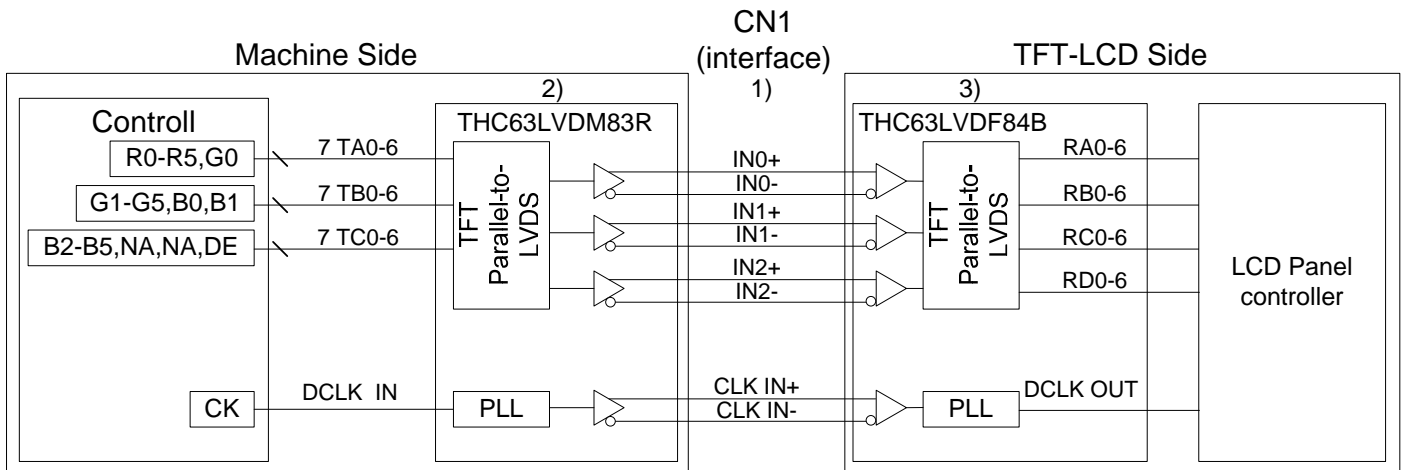

Note 1: LVDS cable impedance should be 100 ohms per signal line when each 2-lines (+, -) is used in differential mode.

Note 2: The recommended transmitter, THC63LVDM83R, is made by Thine or equivalent, which is not contained in the module.

Note 3: The receiver built-in the module is THC63LVDF84B made by Thine.

9.3 LVDS DATA FORMAT

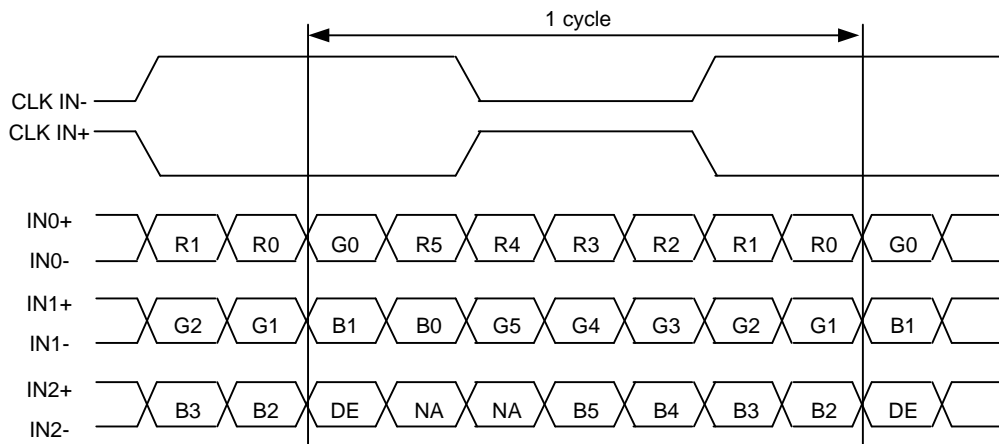

DE: Display Enable

NA: Not Available

9.4 INTERFACE TIMING SPECIFICATIONS

The column of timing sets including minimum, typical, and maximum as below are based on the best optical performance, frame frequency (Vsync) = 60 Hz to define. If 60 Hz is not the aim to set, less than 75 Hz for Vsync is recommended to apply for better performance by other parameter combination as the definitions in section 5.1.

Item		Symbol	Min.	Typ.	Max.	Unit
DCLK	Cycle Frequency	$1/t_{CLK}$	25	33.3	40	MHz
	Low level Width	t_{WCL}	12	-	-	ns
	High level Width	t_{WCH}	12	-	-	
	Rise time / Fill time	t_{rCLK}, t_{fCLK}	-	-	25	
	Duty	D	0.45	0.5	0.55	-
DTMG	Set up time	t_{SI}	5	-	-	ns
	Hold time	t_{HI}	10	-	-	
	Rise/Fall time	t_{r}, t_{f}	-	-	30	ns
	Horizontal Cycle	t_H	841	1056	1088	t_{CLK}
	Horizontal Valid Data width	t_{HD}	800	800	800	
	Horizontal porch width	t_{HB}	41	256	288	
	Vertical Cycle	t_V	495	525	610	t_H
	Vertical Valid Data width	t_{VD}	480	480	480	
Vertical porch width	t_{VB}	15	45	130		
Data	Set up time	t_{SD}	5	-	-	ns
	Hold time	t_{HD}	10	-	-	
	Rise/Fall time	t_{Dr}, t_{Df}	-	-	25	ns

9.5 TIMING CHART

DTMG (Data Enable) is the signal to determine valid data, and the timing of DTMG can be determined from Hsync and Vsync as below. For this display, only DTMG and DCLK are the essential signals. Hsync and Vsync are not necessary to connect to display interface after DTMG has been generated and input.

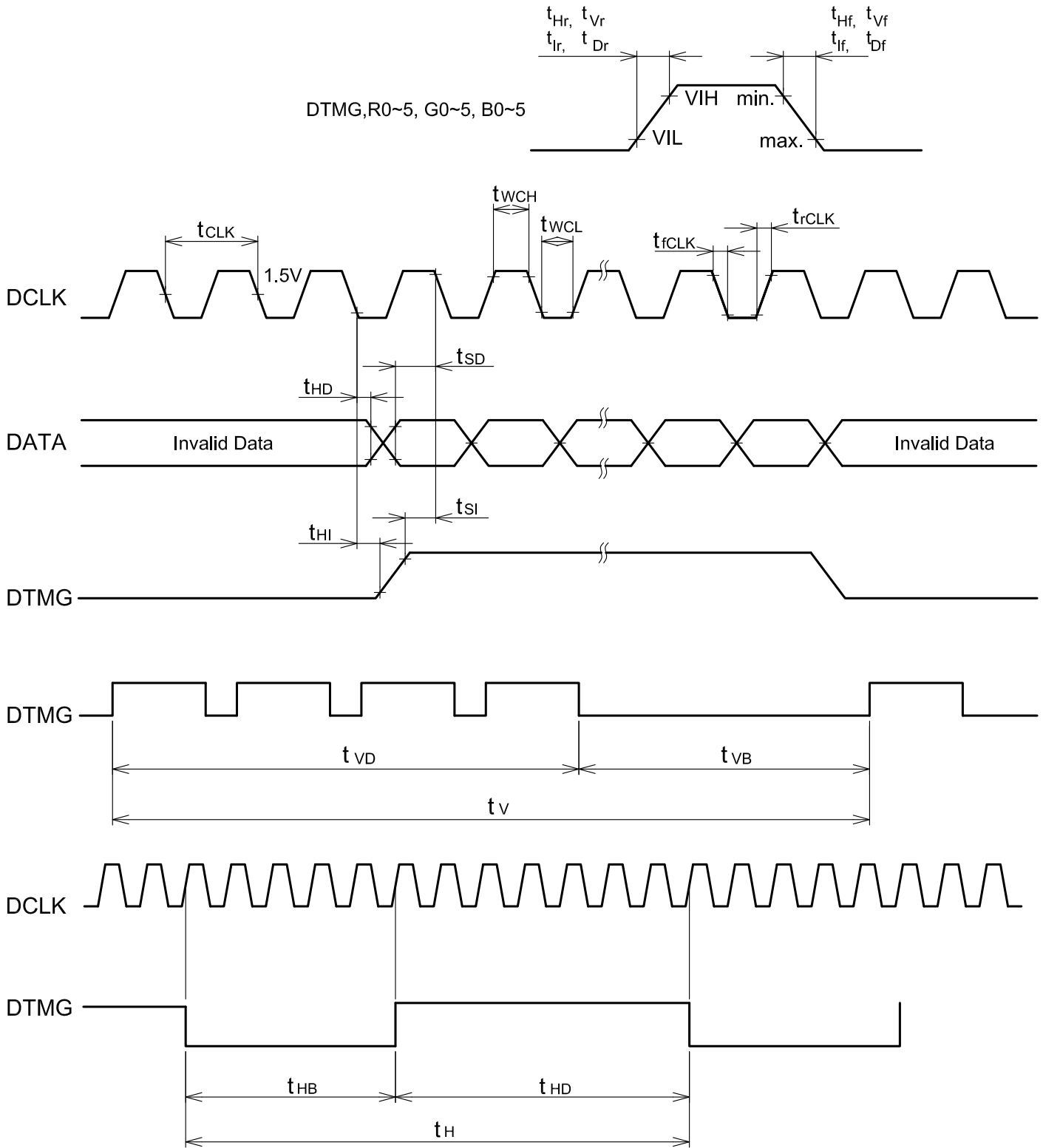

Data is latched by DCLK'S falling edge

9.6 LVDS RECEIVER TIMING

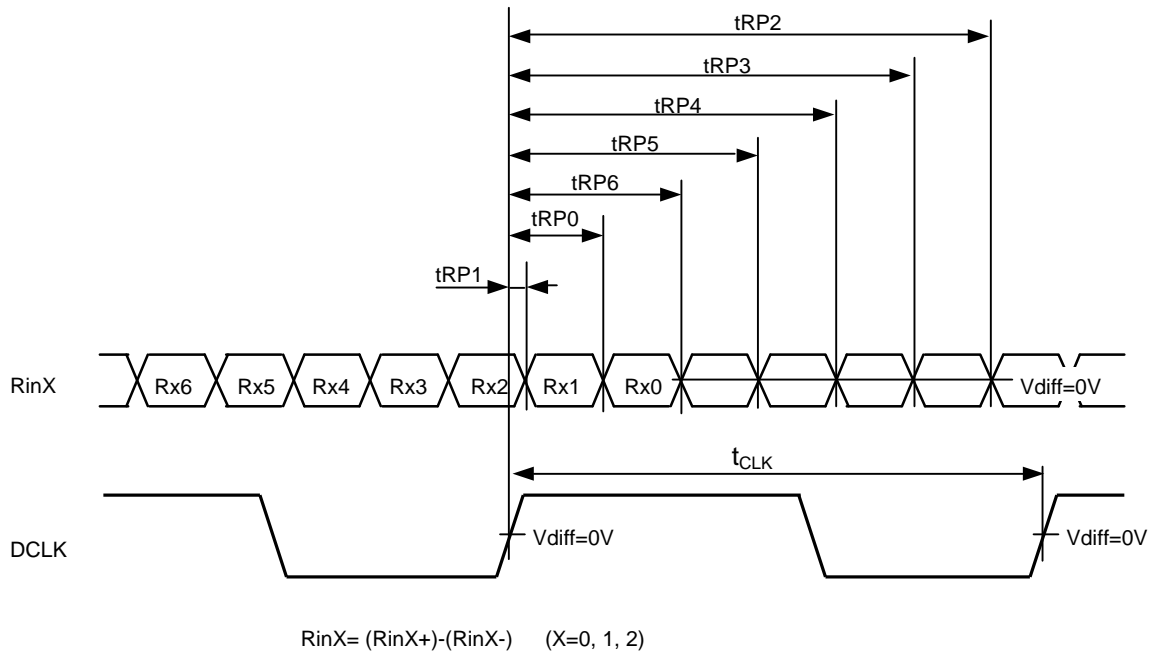

Item	Symbol	Min.	Typ.	Max.	Unit	
DCLK	Frequency	$1/t_{CLK}$	25	33.3	40	MHz
RinX (X=0,1,2)	0 data position	tRP0	$1/7 * t_{CLK} - 0.49$	$1/7 * t_{CLK}$	$1/7 * t_{CLK} + 0.49$	ns
	1st data position	tRP1	-0.49	0	+0.49	
	2nd data position	tRP2	$6/7 * t_{CLK} - 0.49$	$6/7 * t_{CLK}$	$6/7 * t_{CLK} + 0.49$	
	3rd data position	tRP3	$5/7 * t_{CLK} - 0.49$	$5/7 * t_{CLK}$	$5/7 * t_{CLK} + 0.49$	
	4th data position	tRP4	$4/7 * t_{CLK} - 0.49$	$4/7 * t_{CLK}$	$4/7 * t_{CLK} + 0.49$	
	5th data position	tRP5	$3/7 * t_{CLK} - 0.49$	$3/7 * t_{CLK}$	$3/7 * t_{CLK} + 0.49$	
	6th data position	tRP6	$2/7 * t_{CLK} - 0.49$	$2/7 * t_{CLK}$	$2/7 * t_{CLK} + 0.49$	

9.7 DATA INPUT for DISPLAY COLOR

	COLOR & Gray Scale	Data Signal																	
		R5	R4	R3	R2	R1	R0	G5	G4	G3	G2	G1	G0	B5	B4	B3	B2	B1	B0
Basic Color	Black	0	0	0	0	0	0	0	0	0	0	0	0	0	0	0	0	0	0
	Red (0)	1	1	1	1	1	1	0	0	0	0	0	0	0	0	0	0	0	0
	Green (0)	0	0	0	0	0	0	1	1	1	1	1	1	0	0	0	0	0	0
	Blue (0)	0	0	0	0	0	0	0	0	0	0	0	0	1	1	1	1	1	1
	Cyan	0	0	0	0	0	0	1	1	1	1	1	1	1	1	1	1	1	1
	Magenta	1	1	1	1	1	1	0	0	0	0	0	0	1	1	1	1	1	1
	Yellow	1	1	1	1	1	1	1	1	1	1	1	1	0	0	0	0	0	0
	White	1	1	1	1	1	1	1	1	1	1	1	1	1	1	1	1	1	1
Red	Black	0	0	0	0	0	0	0	0	0	0	0	0	0	0	0	0	0	0
	Red (62)	0	0	0	0	0	1	0	0	0	0	0	0	0	0	0	0	0	0
	Red (61)	0	0	0	0	1	0	0	0	0	0	0	0	0	0	0	0	0	0
	:	:	:	:	:	:	:	:	:	:	:	:	:	:	:	:	:	:	:
	:	:	:	:	:	:	:	:	:	:	:	:	:	:	:	:	:	:	:
	Red (1)	1	1	1	1	1	0	0	0	0	0	0	0	0	0	0	0	0	0
	Red (0)	1	1	1	1	1	1	0	0	0	0	0	0	0	0	0	0	0	0
Green	Black	0	0	0	0	0	0	0	0	0	0	0	0	0	0	0	0	0	0
	Green (62)	0	0	0	0	0	0	0	0	0	0	1	0	0	0	0	0	0	0
	Green (61)	0	0	0	0	0	0	0	0	0	0	1	0	0	0	0	0	0	0
	:	:	:	:	:	:	:	:	:	:	:	:	:	:	:	:	:	:	:
	:	:	:	:	:	:	:	:	:	:	:	:	:	:	:	:	:	:	:
	Green (1)	0	0	0	0	0	0	1	1	1	1	1	0	0	0	0	0	0	0
	Green (0)	0	0	0	0	0	0	1	1	1	1	1	1	0	0	0	0	0	0
Blue	Black	0	0	0	0	0	0	0	0	0	0	0	0	0	0	0	0	0	0
	Blue (62)	0	0	0	0	0	0	0	0	0	0	0	0	0	0	0	0	0	1
	Blue (61)	0	0	0	0	0	0	0	0	0	0	0	0	0	0	0	0	1	0
	:	:	:	:	:	:	:	:	:	:	:	:	:	:	:	:	:	:	:
	:	:	:	:	:	:	:	:	:	:	:	:	:	:	:	:	:	:	:
	Blue (1)	0	0	0	0	0	0	0	0	0	0	0	0	1	1	1	1	1	0
	Blue (0)	0	0	0	0	0	0	0	0	0	0	0	0	1	1	1	1	1	1

9.8 POWER SEQUENCE

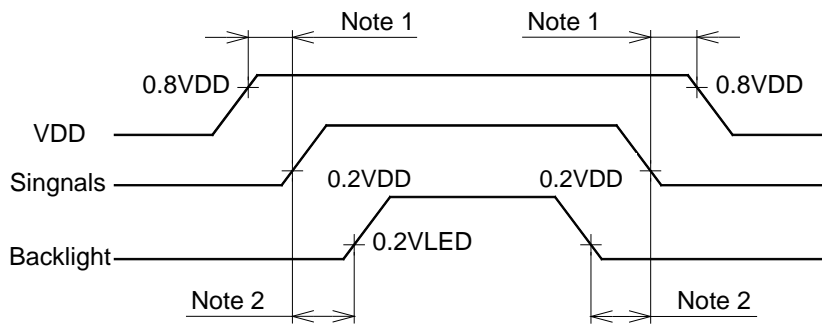

Power Sequence Timing

Note 1: In order to avoid any damages, VDD has to be applied before all other signals. The opposite is true for power off where VDD has to be remained on until all other signals have been switch off. The recommended time period is 1 second. Hot plugging might cause display damage due to incorrect power sequence, please pay attention on interface connecting before power on.

Note 2: In order to avoid showing uncompleted patterns in transient state. It is recommended that switching the backlight on is delayed for 1 second after the signals have been applied. The opposite is true for power off where the backlight has to be switched off 1 second before the signals are removed.

10. OUTLINE DIMENSIONS

10.1 FRONT VIEW

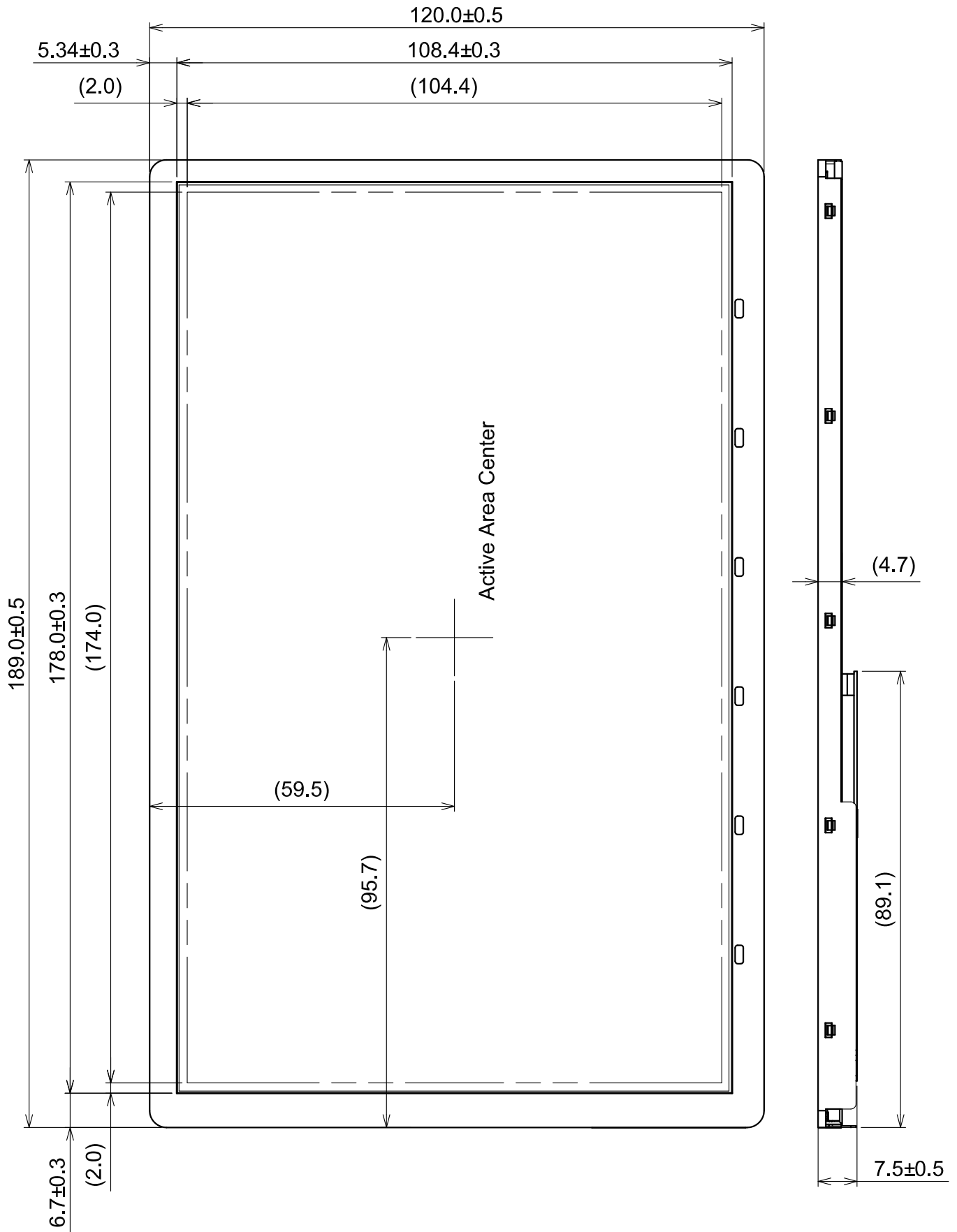

Unit : mm

10.2 REAR VIEW

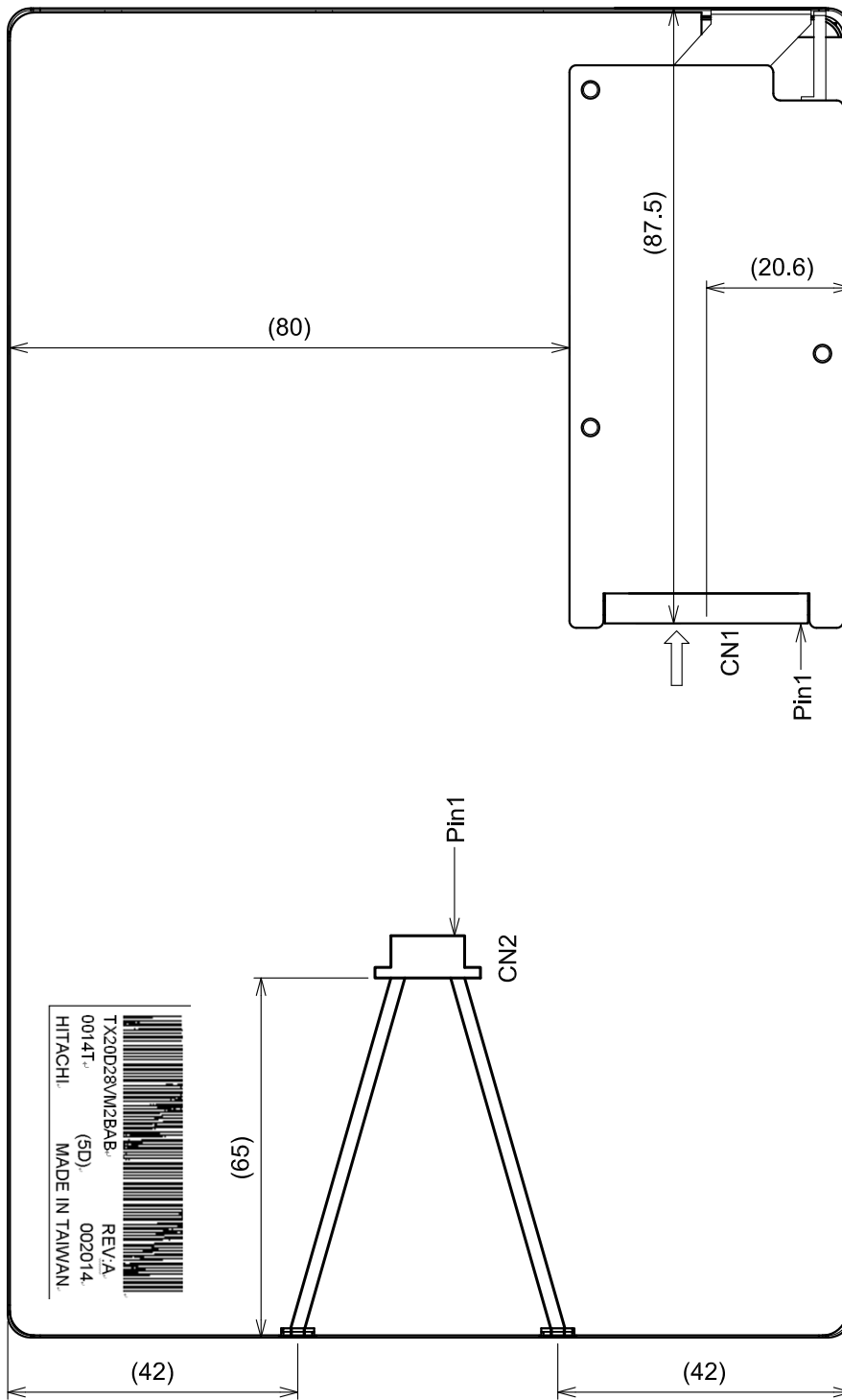

Note 1) CN1 : FA5B040HP1R3000
 CN2 : BHR-03VS-1(JST)

Unit : mm

11. APPEARANCE STANDARD

The appearance inspection is performed in a dark room around 500~1000 lx based on the conditions as below:

- The distance between inspector's eyes and display is 30 cm.
- The viewing zone is defined with angle θ shown in Fig. 11.1. The inspection should be performed within 45° when display is shut down. The inspection should be performed within 5° when display is power on.

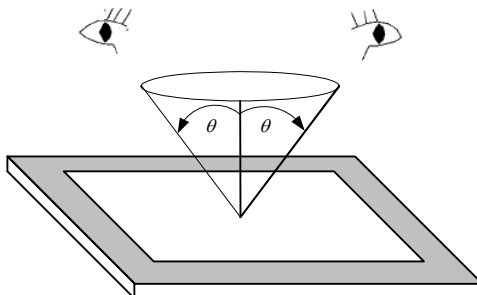

Fig. 11.1

11.1 THE DEFINITION OF LCD ZONE

LCD panel is divided into 3 areas as shown in Fig.11.2 for appearance specification in next section. A zone is the LCD active area (dot area); B zone is the area, which extended 1 mm out from LCD active area; C zone is the area between B zone and metal frame.

In terms of housing design, B zone is the recommended window area customers' housing should be located in.

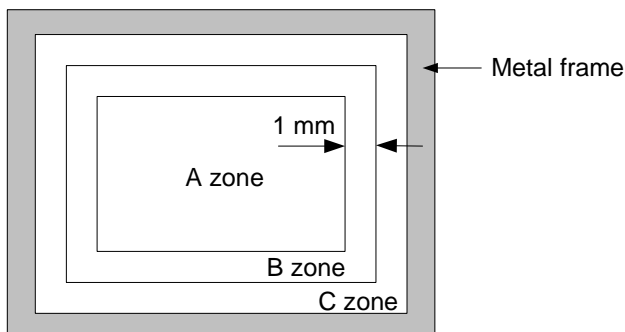

Fig. 11.2

11.2 LCD APPEARANCE SPECIFICATION

The specification as below is defined as the amount of unexpected phenomenon or material in different zones of LCD panel. The definitions of length, width and average diameter using in the table are shown in Fig. 11.3 and Fig. 11.4.

Item	Criteria				Applied zone	
	Length (mm)	Width (mm)	Maximum number	Minimum space		
Scratches	Ignored	$W \leq 0.01$	Ignored	-	A	
	$L \leq 40$	$W \leq 0.02$	10	-		
	$L \leq 20$	$W \leq 0.04$	10	-		
	Round (Dot Shape)					
	Average diameter (mm)		Maximum number	Minimum space		
	$D \leq 0.2$		Ignore	-		
	$D \leq 0.4$		10	-		
	Dent	Serious one is not allowed				A
Wrinkles in polarizer	Serious one is not allowed				A	
Bubbles on polarizer	Average diameter (mm)		Maximum number		A	
	$D \leq 0.3$		Ignored			
	$D \leq 0.5$		10			
	$D \leq 1.0$		5			
1) Stains 2) Foreign Materials 3) Dark Spot	Filamentous (Line shape)				A	
	Length (mm)		Width (mm)			
	Ignored		$W \leq 0.02$			
	$L \leq 2.0$		$W \leq 0.03$			
	$L \leq 1.0$		$W \leq 0.06$			
	Round (Dot shape)				A	
	Average diameter (mm)		Maximum number			
	$D \leq 0.22$		Ignored			
	$D \leq 0.33$		5			
	$D > 0.33$		0			
	In total		Filamentous + Round=10			
	Those wiped out easily are acceptable					
	Dot-Defect (Note 1)	Bright dot-defect		Type	Maximum number	A
				1 dot	4	
2 adjacent dot				1		
3 adjacent dot or above				Not allowed		
Density				$2/\phi 20\text{mm}$		
In total		5				
Dark dot-defect		1 dot	5			
		2 adjacent dot	2			
		3 adjacent dot or above	Not allowed			
		Density	$3/\phi 20\text{mm}$			
		In total		5		
In total		10				

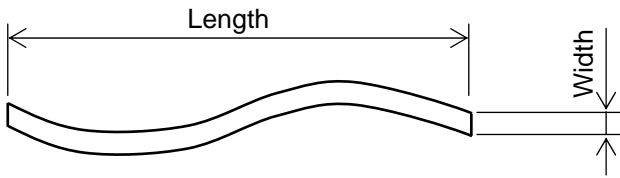

Fig 11.3

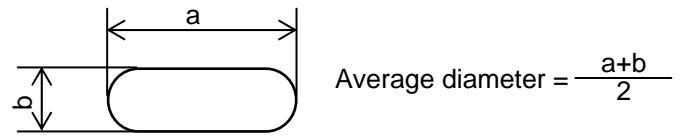

Fig 11.4

Note 1: The definitions of dot defect are as below:

- The defect area of the dot must be bigger than half of a dot.
- For bright dot-defect, showing black pattern, the dot's brightness must be over 30% brighter than others.
- For dark dot-defect, showing white pattern, the dot's brightness must be under 70% darker than others.
- The definition of 1-dot-defect is the defect-dot, which is isolated and no adjacent defect-dot.
- The definition of adjacent dot is shown as Fig. 11.5.
- The Density of dot defect is defined in the area within diameter $\phi = 20\text{mm}$.

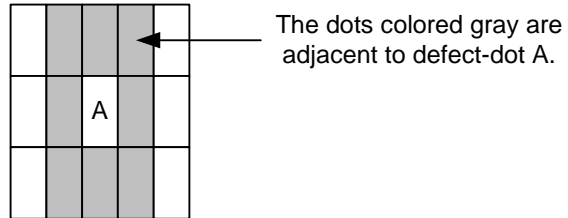

Fig. 11.5

12. PRECAUTIONS

12.1 PRECAUTIONS of ESD

- 1) Before handling the display, please ensure your body has been connected to ground to avoid any damages by ESD. Also, do not touch display's interface directly when assembling.
- 1) Please remove the protection film very slowly before turning on the display to avoid generating ESD.

12.2 PRECAUTIONS of HANDLING

- 1) In order to keep the appearance of display in good condition; please do not rub any surfaces of the displays by sharp tools harder than 3H, especially touch panel, metal frame and polarizer.
- 2) Please do not pile the displays in order to avoid any scars leaving on the display. In order to avoid any injuries, please pay more attention for the edges of glasses and metal frame, and wear finger cots to protect yourself and the display before working on it.
- 2) Touching the display area or the terminal pins with bare hand is prohibited. This is because it will stain the display area and cause poor insulation between terminal pins, and might affect display's electrical characteristics furthermore.
- 3) Do not use any harmful chemicals such as acetone, toluene, and isopropyl alcohol to clean display's surfaces.
- 4) Please use soft cloth or absorbent cotton with ethanol to clean the display by gently wiping. Moreover, when wiping the display, please wipe it by horizontal or vertical direction instead of circling to prevent leaving scars on the display's surface, especially polarizer.
- 5) Please wipe any unknown liquids immediately such as saliva, water or dew on the display to avoid color fading or any permanently damages.
- 6) Maximum pressure to the surface of the display must be less than $1,96 \times 10^4$ Pa. If the area of adding pressure is less than 1 cm^2 , the maximum pressure must be less than 1.96N.

12.3 PRECAUTIONS OF OPERATING

- 1) Please input signals and voltages to the displays according to the values defined in the section of electrical characteristics to obtain the best performance. Any voltages over than absolute maximum rating will cause permanent damages to this display. Also, any timing of the signals out of this specification would cause unexpected performance.
- 2) When the display is operating at significant low temperature, the response time will be slower than it at 25 C° . In high temperature, the color will be slightly dark and blue compared to original pattern. However, these are temperature-related phenomenon of LCD and it will not cause permanent damages to the display when used within the operating temperature.
- 3) The use of screen saver or sleep mode is recommended when static images are likely for long periods of time. This is to avoid the possibility of image sticking.
- 4) Spike noise can cause malfunction of the circuit. The recommended limitation of spike noise is no bigger than $\pm 100 \text{ mV}$.

KAOHSIUNG HITACHI ELECTRONICS CO., LTD.	SHEET NO.	7B64PS 2712-TX20D28VM2BAB-2	PAGE	12-1/2
--	--------------	-----------------------------	------	--------

12.4 PRECAUTIONS of STORAGE

If the displays are going to be stored for years, please be aware the following notices.

- 1) Please store the displays in a dark room to avoid any damages from sunlight and other sources of UV light.
- 2) The recommended long-term storage temperature is between 10C° ~ 35C° and 55%~75% humidity to avoid causing bubbles between polarizer and LCD glasses, and polarizer peeling from LCD glasses.
- 3) It would be better to keep the displays in the container, which is shipped from Hitachi, and do not unpack it.
- 4) Please do not stick any labels on the display surface for a long time, especially on the polarizer.

12.5 MOUNTING PRECAUTION

- 1) When assembling the LCM Module, please refer to the below.
- 2) The use of cushion is recommended in order to protect the module from shock.

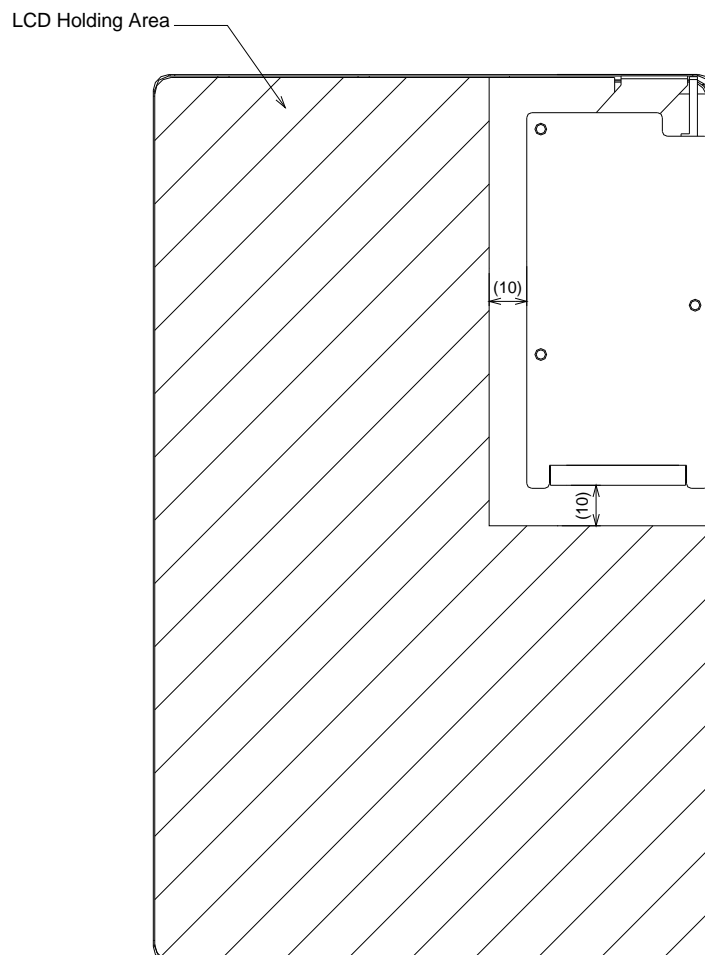

13. DESIGNATION of LOT MARK

1) The lot mark is showing in Fig.13.3. First 4 digits are used to represent production lot, T represented made in Taiwan, and the last 6 digits are the serial number.

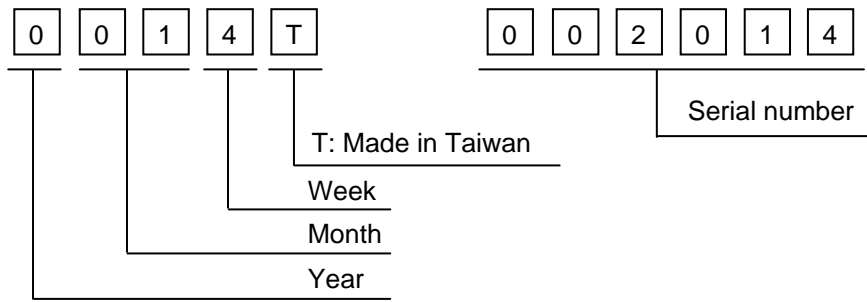

2) The tables as below are showing what the first 4 digits of lot mark are shorted for.

Year	Mark
2010	0
2011	1
2012	2
2013	3
2014	4

Month	Mark	Month	Mark
1	01	7	07
2	02	8	08
3	03	9	09
4	04	10	10
5	05	11	11
6	06	12	12

Week (Days)	Mark
1~7	1
8~14	2
15~21	3
22~28	4
29~31	5

3) Except letters I and O, revision number will be shown on lot mark and following letters A to Z.

4) The location of the lot mark is on the back of the display shown in Fig. 13.3.



Fig 13.3