

12.1" Infrared Touch Panel

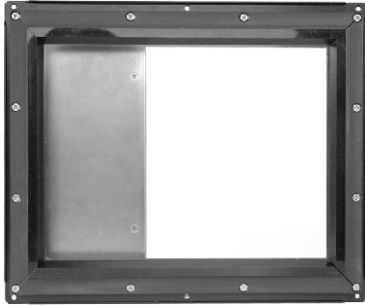

Vishay Dale Electronics TIP products are infrared touch panels designed to fit most flat panel display technologies. The touch panels consist of infrared emitters and detectors, scanning electronics, a microprocessor based controller, a bezel and optical filter assembly, and hardware to mount the touch panel assembly to the flat panel display.

These touch panels are ideal for many applications including medical instrumentation, machine or process controllers, point of sale devices, public information displays, banking terminals, and military.

ORDERING INFORMATION

TOUCH PANEL	TIP-4131SCE-1
TBDriver (DOS driver)	280879-08
TWDriver (Windows 3.1 driver)	280879-10
T5Driver (Windows 95/98 driver)	280879-11
UPDD universal pointer device driver	280879-12
J1 mating connector	280105-02
J4 mating connector	280108-06
J5 mating connector	280108-05

Note

- If a manual is required for TBDriver, TWDriver, T5Driver or UPDD, please request at the time of ordering. These will be included as no charge items.

FEATURES

- Fast response time < 50 ms
- 81 x 61 switch matrix, nearly 5000 switches
- Fits Sharp LQ121S1DG11 directly
- Clear hardcoated anti-glare filter
- Sealed for environmental resistance
- Immune to high or changing ambient light
- RS-232 interface
- Pre-assembled - no assembly or disassembly required to mount display

ELECTRICAL SPECIFICATIONS

Voltage: + 5 V_{DC} ± 5 %

Current: 200 mA typical

Beeper Output: HC CMOS type

ENVIRONMENTAL SPECIFICATIONS

Operating Temperature: 0 °C to + 55 °C

Storage Temperature: - 55 °C to + 85 °C

Relative Humidity: 10 % to 90 % non-conditioning

Ambient Light: 2000 ft candles

INTERFACE

Type: RS-232 serial

Data Rate: 9600 baud or 19.2 kilo-baud

Word Format: 8 data bits, no parity, 1 start bit, 1 stop bit

Touch Points: 81 x 61

DIMENSIONS in inches [millimeters]

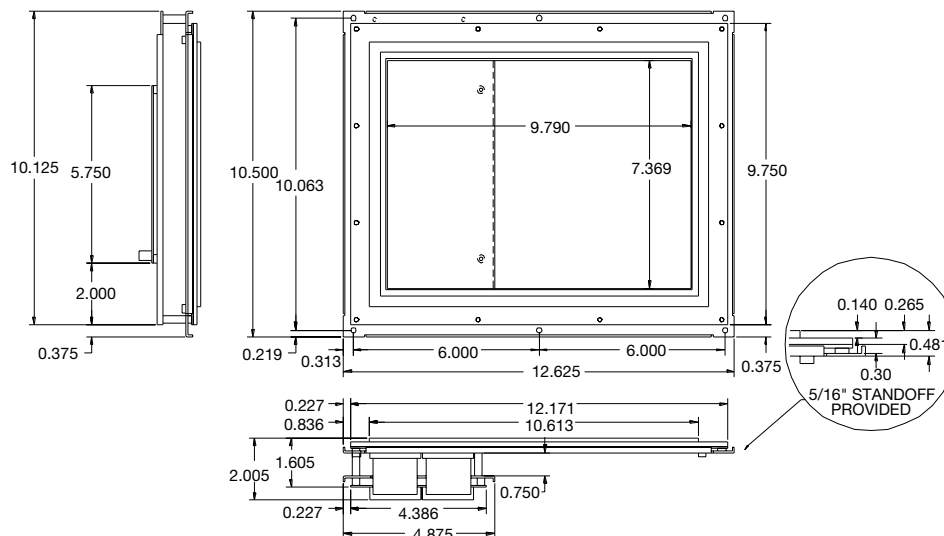

GENERAL DESCRIPTION

Each panel has infrared LED emitters and phototransistors along the X- and Y-axis, forming a grid of infrared light beams across the face of the display. The first two numbers of the TIP "matrix" number specify the number of X-axis (vertical) beams, and the last two numbers specify the number of Y (horizontal) beams. The controller scans the emitter/detector pairs one at a time and determines whether both X and Y beams are blocked, indicating that a finger or stylus is present. (When beams are blocked on only one axis, they are ignored and not reported.) The controller determines the coordinates of the touch point and reports it to the host computer. By interpolating, a "virtual" beam between two physical beams, the number of touch points on each axis is effectively doubled. When an odd number of beams along either axis is blocked, the coordinate of the center physical beam is reported. When an even number of beams is blocked, the coordinate of the virtual beam in the center of the blocked beams is calculated and reported.

Vishay Dale's TIP touch panels have a unique patented scanning and logic system that make them virtually immune to most lighting environments.

The touch controller supports *enter*, *exit*, *continuous*, and *tracking* report modes or combinations of these modes. The controller also has a beeper output. Hardware handshaking, software handshaking, baud rates, and X, Y coordinate invert features are jumper selected. The user initializes the desired report modes, coordinates are reported automatically or upon request as needed. Several optical filters are standard to provide the most cost effective filter for each application. "Non-standard" filters may be specified as well.

The filter increases the contrast ratio of the display and protects the display face and electronics. Vishay Dale can assist in recommending the optimum filter based on years of experience as a display manufacturer. The perimeter of the filter is bonded to the bezel, and a bezel to front panel gasket is included to provide a splash proof seal.

Optional PC based software provides simple touch panel integration (see ordering instructions).

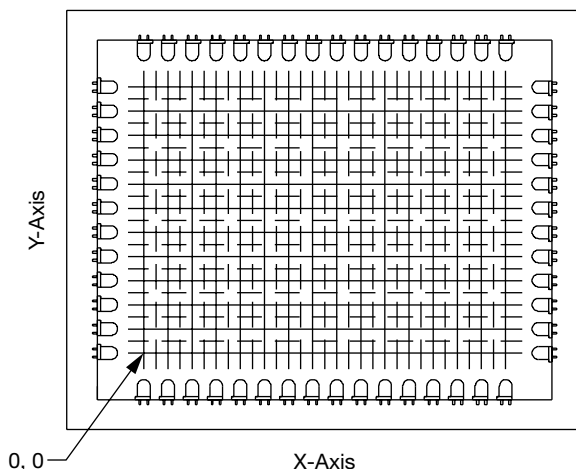

T5Driver emulates a mouse in Windows 95/98 applications.
 TWDriver emulates a mouse in Windows applications.
 TBDriver emulates a mouse in DOS applications.

Generic drivers or drivers for other operating systems are available through Touch Base, Ltd. Contact Vishay Dale for information. (Windows is a registered trademark of the Microsoft Corporation.)

PIN CONNECTIONS					
J1 DATA CONNECTOR					
TOUCH PANEL CONNECTOR			HOST CONNECTOR		
10 PIN	9 dB		9 dB	25 dB	
PIN	PIN	DESCRIPTION	PIN	PIN	DESCRIPTION
1	1	N/C (reserved)			
2	6	N/C (reserved)			
3	2	TxD (output)	2	3	RxD
4	7	CTS (input)	7	4	RTS
5	3	RxD (input)	3	2	TxD
6	8	RTS (output)	8	5	CTS
7	4	DSR (input)	4	20	DTR
8	9	N/C (reserved)			
9	5	Ground	5	7	Ground
10	-	N/C (reserved)			

To make a serial communication cable, use insulation displacement connectors (IDC). Press a 10 pin IDC connector onto one end of the ribbon cable, press a 9 dB connector onto the other end. Match pin 1 of the 10 pin to pin 1 of the 9 dB, the 10th pin is not used on the 9 dB.

The busy indicator from the host may be changed from CTS to DSR by changing the position of the jumper at W3.

MATING CONNECTORS		
	VISHAY	OTHER
J1	280105-02	AMP 746285-1
J2, J3	280105-04	AMP 746285-4
J4	280108-06	MOLEX 22-01-3037 housing, 08-50-0114 terminals
J5	280108-05	AMP 1-480424-0 housing, 350689-1 socket terminals

J4 AUDIO FEED BACK CONNECTOR (BEEPER)

PIN	DESCRIPTION
1	Ground
2	Beeper signal (active low)
3	Beeper power output (+ 5 V _{DC})

J5 POWER CONNECTOR

PIN	DESCRIPTION
1	N/C
2	Ground
3	Ground
4	+ 5 V

W1 JUMPERS

Baud rate (select 1)
 19 200 baud or 9600 baud
 Software handshaking
 Normal X
 Normal Y



COMMANDS (code sent to touch panel)		
COMMAND	CODE (HEX)	CODE (ASCII)
DC1, Ctl Q, XON software handshaking	11	DC1
DC3, Ctl S, XOFF software handshaking	13	DC3
Enable touch panel	26	&
Disable touch panel (stop scanning)	27	'
Enable <i>continuous</i> /disable <i>tracking</i> mode	24	\$
Disable <i>continuous</i> and <i>tracking</i> mode ⁽¹⁾	25	%
Enable <i>tracking</i> /disable <i>continuous</i> mode	34	4
Enable <i>enter</i> point mode	22	"
Disable <i>enter</i> point mode ⁽¹⁾	23	#
Enable <i>exit</i> point mode	20	SP
Disable <i>exit</i> point mode ⁽¹⁾	21	!
Enable automatic report transfer	29)
Disable automatic report transfer (scan but no report) ⁽¹⁾	2A	*
Enable beeper (not supported on this model)	2D	-
Disable beeper (not supported on this model) ⁽¹⁾	2E	.
Failed beam time-out t = duration (0 to F) (default = 1)	3At	:
Normal X ⁽¹⁾	36	6
Invert X	37	7
Normal Y ⁽¹⁾	38	8
Invert Y	39	9
Reset touch panel	2C	,
Request one coordinate report	2B	+
Request failed beam report	28	(
Request model number	35	5
Request software revision number	30	0
Request touch matrix size	33	3
Sound beeper, tt = duration (00 to FF) (not supported on this model)	2Ftt	/

Note

⁽¹⁾ Indicates default condition

RESPONSE (code received from touch panel)		
RESPONSE	CODE (HEX)	CODE (ASCII)
DC1, Ctl Q, XON software handshaking	11	DC1
DC3, Ctl S, XOFF software handshaking	13	DC3
<i>Continuous</i> touch coordinates, X, Y - binary X and Y, ≥ 0 - X, Y = FE if non-contiguous	41 xx yy	A
<i>Enter</i> touch coordinates X, Y - binary X and Y, ≥ 0 - X, Y = FE if non-contiguous	42 xx yy	B
<i>Exit</i> touch coordinates, X, Y - binary X and Y, ≥ 0 - X, Y = FE if non-contiguous	43 xx yy	C
<i>Tracking</i> touch coordinates, X, Y - binary X and Y, ≥ 0 - X, Y = FE if non-contiguous	4E xx yy	N
No coordinate report available	48	H
Failed beams, bad photo pairs, end	47 aa-nn FF	G
RS-232 error (overrun or framing)	45	E
Model number, string, end - aaaa = variable length ASCII string	50 aaaa FF	P
Software revision number, string, end - aaa = variable length ASCII string	4C aaa FF	L
Matrix size, max. X + 1, max. Y + 1	4D xx yy	M
Buffer overflow error	4F	O



COMMAND/RESPONSE DESCRIPTION

DC1, Ctl Q, XON software handshaking (11)

DC3, Ctl S, XOFF software handshaking (13)

RS-232 flow control is provided by these commands.

Note

- A shunt must be placed on (*softhand*) to allow software handshaking. Absence of a shunt requires hardware handshaking. (See also *enable touch panel* command)

Enable touch panel (26)

Disable touch panel (stop scanning) (27)

The touch panel must be enabled for normal operation. When the touch panel is disabled, commands are processed as they are received, allowing changes in modes of operation, but discarding any report operations. This differs from XON/XOFF software handshaking. When the touch panel receives an XOFF character (13), commands are executed until the touch panel requires transmission of a report, then all commands received are buffered and are not executed until an XON character is received. If the buffer becomes full, the touch panel sends XOFF.

Enable *continuous*/disable *tracking* mode (24)

Disable *continuous* and *tracking* mode ⁽¹⁾ (25)

This coordinate reporting mode will continuously report the coordinates of a stylus that remains in the touch panel. This mode can be used individually or in combination with *enter* point, or *exit* modes. The following report format is used. If more than one stylus enters the touch panel, a non-contiguous report will be generated.

41 = start of coordinate report

xx yy = binary X and Y, ≥ 0 , X, Y = FE if non-contiguous

Enable *enter* point mode (22)

Disable *enter* point mode ⁽¹⁾ (23)

This coordinate reporting mode will report the coordinates of the point where a stylus is entered into the touch panel. This mode can be used individually or in combination with *exit* point, *continuous*, or *tracking* modes. The following report format is used. If more than one stylus enters the touch panel, a non-contiguous report will be generated.

42 = start of enter report

xx yy = binary X and Y, ≥ 0 , X, Y = FE if non-contiguous

Enable *exit* point mode (20)

Disable *exit* point mode ⁽¹⁾ (21)

This coordinate reporting mode will report the coordinate of the point where a stylus is removed from the touch panel. This mode can be used individually or in combination with *enter* point, *continuous*, or *tracking* modes. The following report format is used. If more than one stylus enters the touch panel, a non-contiguous report will be generated.

43 = start of exit report

xx yy = binary X and Y, ≥ 0 , X, Y = FE if non-contiguous

Enable *tracking*/disable *continuous* mode (34)

This coordinate reporting mode will report the coordinates of a stylus that remains in the touch panel, but only as the stylus changes locations. This mode can be used individually or in combination with *enter* point, or *exit* modes. The following report format is used. If more than one stylus enters the touch panel, a non-contiguous report will be generated.

4E = start of coordinates report

xx yy = binary X and Y, ≥ 0 , X, Y = FE if non-contiguous

Enable automatic reporting (29)

Disable automatic reporting (scan but no report) ⁽¹⁾ (2A)

Request one coordinate report (2B)

When *automatic reporting* is enabled, coordinate reports are reported to the host as soon as they become available. After issuing the *enable automatic reporting* command, there may be a report in the internal buffer which is not current. If a sufficient amount of time has passed to allow this condition, the first coordinate report returned should be ignored.

When *automatic reporting* is disabled, no coordinate reports are reported unless requested with *request one coordinate report*. If a stylus is entered into the touch panel after *automatic reporting* is disabled, a coordinate report will be generated and saved in an internal buffer (depending upon coordinate reporting modes in effect) but will not be transmitted until a *request one coordinate report* command is received.

If no coordinate report is available in the internal buffer, the touch panel will return a code 48 and continue to scan until a stylus is detected. However, no coordinate report will be reported until *automatic reporting* is enabled or the report is requested with *request one coordinate report*.

Coordinate reports are reported with the following format:

Report type = 41, 42, 43, or 4E

xx yy = binary X and Y, ≥ 0 , X, Y = FE if non-contiguous

Enable Beeper (2D)

Disable Beeper ⁽¹⁾ (2E)

Enabling the beeper sends a logic 0 (active state) to pin 2 of J4 depending on which of the coordinate reporting modes are enabled. If the *enter* mode is enabled, a pulse is sent for every entry point. If the *exit* mode is enabled, a pulse is sent for every exit point. If both modes are enabled, a pulse is sent for every entry and exit point. *Continuous* and *tracking* modes have no beeper outputs.

Sound beeper, tt = duration (00 to FF) (2Ftt)

This command sends a logic 0 (active state) to pin 2 of J4. The duration of the beep can be controlled in 10 ms increments from 0 ms (00) to 2.55 s (FF).

Note

- 2C may not be used as an argument as it will cause a reset.



Normal X (1) (36)

Invert X (37)

Normal Y (1) (38)

Invert Y (39)

The standard configuration for the touch panel places the XY origin at the lower left corner, consistent with the Cartesian coordinate system. Upon issuing the *invert Y* command, the origin becomes the upper left corner, consistent with the video industry standard. These commands allow the user to move the origin to any corner to accomodate different standards or third party mechanical packages which may have the touch panel rotated 180° on the display. To cancel an *invert X* or *invert Y* command, a *normal X* or *normal Y* command must be executed. These commands may also be implemented with jumpers. Placing a shunt on NOR X causes X data to be normal (default), and removing the shunt causes inverted X data. Similarly, placing a shunt on NOR Y causes Y data to be normal (default), or removal causes inverted Y data. The jumper selected options may be over-riden with the software commands.

Failed beam time-out (3A t)

If any IR beam is broken for an extended time due to blockage of the beam or failed optical components, the touch panel will ignore that beam after a predetermined number of scans. (This is to prevent failed beams from interfering with touch sensing). The actual failed beam detection time depends on the modes of operation and the size of the touch matrix. When using the *continuous* mode with *automatic reporting* enabled, the time is typically 25 s to 30 s. If the application requires longer touch times, then the time may be extended using the *failed beam time-out* command. The command accepts arguments from 1 to F.

Request failed beam report (28)

This command returns the address of any infrared diode/ phototransistor pair that are blocked (as when a stylus is in the panel) or have several failed scans. (The time period can be extended by using the *failed beam time-out* command). The report uses the following format:

47 = start of failed beam report

aa-nn = physical address of failed LED/phototransistor pair

FF = end of report

Reset touch panel (2C)

After issuing the *reset* command, the touch panel is returned to its power up condition and all operating modes are returned to their default state and the buffer cleared.

Request software revision number (30)

Request touch matrix size (33)

Request model number (35)

These commands are provided for configuration control and diagnostic purposes.

RS-232 framing or overrun error (45)

An RS-232 error indicates communication problems.

Buffer overflow error (4F)

Buffer overflow occurs when the input command buffer is exceeded due to lack of handshaking.

INITIALIZATION

Initialization is performed by the host computer and must be done each time the touch panel is powered up or the *reset touch panel* command is issued. The initialization process requires setting the desired coordinate reporting modes, enabling or disabling *automatic reporting*, and enabling or disabling the touch panel. Default settings are shown in the *commands* table.

When touch coordinate information is required by the host computer, the touch panel must be enabled. The flow of touch coordinates from the touch panel to the host computer can be controlled by enabling or disabling *automatic reporting*. With *automatic reporting* enabled, coordinate reports are sent to the host as soon as they become available. If the host computer is performing a task which does not require touch coordinate information, *automatic reporting* may be disabled.

INITIALIZATION/OPERATION-EXAMPLE

In the following example the touch panel is initialized to report coordinates only when a stylus is entered into the touch panel.

The touch panel is enabled by default, and coordinate reporting is not desired unless requested, so *automatic reporting* is left disabled by default.

As a result the touch panel must be continuously polled with *request one coordinate report (2B)* to determine if an enter point coordinate report is available. When a report is available, it will be sent to the host. If no report is available, the touch panel will send code 48 (hex) to the host.

HOST	TOUCH PANEL	ACTION
Send 22 Send 2B		Enables <i>enter</i> point mode Request report
	Send 48	No report is available
Send 2B		Request report
	Send 42, 1D, 12	A stylus entered the touch panel. The coordinates are X29, and Y18 (decimal) (See touch point format)
Send 2B		Request report
	Send 48	No report is available

MOUNTING

The touch panel and display assembly should be mounted in accordance with mounting instructions specified herein, and as separately specified by the display manufacturer. The vibration and shock specifications only apply to the complete assembly when properly mounted in a rigid front panel.

CLEANING

The bezel is manufactured from polycarbonate which is compatible with most cleaning agents such as alcohol, window cleaners, and soap and water. Solvent type cleaning agents should only be used for wiping. Filters are made from polyester, polycarbonate, or acrylic and also should withstand the above cleaning agents. Care must be taken to avoid scratching the bezel or filter by cleaning with abrasive or coarse cloths, use only soft cotton. While scratches normally will not affect the function of the touch panel, they will degrade the appearance of the end product and make the display difficult to read.

WARRANTY

Vishay Dale warrants that TIP infrared touch panels will be free from defects in materials and workmanship, and that they will function substantially to these specifications. The TIP touch panels are warranted for one year from shipment from Vishay Dale. Cosmetic defects (bezel and filter scratches and blemishes) are not warranted unless they are present when the product is first delivered from Vishay Dale Electronics, Inc. Bezel/filter assemblies with cosmetic defects must be returned within 30 days of delivery.

The purchaser must return the defective or nonconforming goods to Vishay Dale not later than 30 days after Vishay Dale's issuance of an RMA number. No goods are to be returned without issuance of an RMA number. For an RMA number, contact the Vishay Dale's customer service department with the model number(s) and original purchase order number(s).

When returning goods for repair, please include a brief description of the problem, and mark the outside of the shipping container with the RMA number. The buyer shall prepay transportation charges, and Vishay Dale shall pay for the return of the goods to the buyer.

The warranty does not apply in cases of improper or inadequate installation or maintenance by the buyer, unauthorized modification of the product, operation of the product outside their environmental specifications, neglect or abuse of the product.

This warranty is not the full warranty, and should not be interpreted as a substitute for the full warranty.

ELECTROSTATIC CAUTION

Vishay Dale TIP touch panels use electrostatic sensitive components. These assemblies should be unpacked and handled in an ESD controlled area only. When shipping, use packing materials designed for protection of electrostatic sensitive components.

Vishay Dale Electronics, Inc. believes that the information described in this publication is accurate and reliable, and much care has been taken in its preparation. However, no responsibility, financial, or otherwise, is accepted for any consequences arising out of the use of this information. This information is subject to change without notice.



Disclaimer

ALL PRODUCT, PRODUCT SPECIFICATIONS AND DATA ARE SUBJECT TO CHANGE WITHOUT NOTICE TO IMPROVE RELIABILITY, FUNCTION OR DESIGN OR OTHERWISE.

Vishay Intertechnology, Inc., its affiliates, agents, and employees, and all persons acting on its or their behalf (collectively, "Vishay"), disclaim any and all liability for any errors, inaccuracies or incompleteness contained in any datasheet or in any other disclosure relating to any product.

Vishay makes no warranty, representation or guarantee regarding the suitability of the products for any particular purpose or the continuing production of any product. To the maximum extent permitted by applicable law, Vishay disclaims (i) any and all liability arising out of the application or use of any product, (ii) any and all liability, including without limitation special, consequential or incidental damages, and (iii) any and all implied warranties, including warranties of fitness for particular purpose, non-infringement and merchantability.

Statements regarding the suitability of products for certain types of applications are based on Vishay's knowledge of typical requirements that are often placed on Vishay products in generic applications. Such statements are not binding statements about the suitability of products for a particular application. It is the customer's responsibility to validate that a particular product with the properties described in the product specification is suitable for use in a particular application. Parameters provided in datasheets and/or specifications may vary in different applications and performance may vary over time. All operating parameters, including typical parameters, must be validated for each customer application by the customer's technical experts. Product specifications do not expand or otherwise modify Vishay's terms and conditions of purchase, including but not limited to the warranty expressed therein.

Except as expressly indicated in writing, Vishay products are not designed for use in medical, life-saving, or life-sustaining applications or for any other application in which the failure of the Vishay product could result in personal injury or death. Customers using or selling Vishay products not expressly indicated for use in such applications do so at their own risk and agree to fully indemnify and hold Vishay and its distributors harmless from and against any and all claims, liabilities, expenses and damages arising or resulting in connection with such use or sale, including attorneys fees, even if such claim alleges that Vishay or its distributor was negligent regarding the design or manufacture of the part. Please contact authorized Vishay personnel to obtain written terms and conditions regarding products designed for such applications.

No license, express or implied, by estoppel or otherwise, to any intellectual property rights is granted by this document or by any conduct of Vishay. Product names and markings noted herein may be trademarks of their respective owners.