

TTL & HCMOS PRECISION OSCILLATORS

DFN 14-KB, DFN 4-KB & DFN 4-KH

KEY FEATURES

1 to 70 MHz

± 15 ppm overall stability available

Encapsulated crystal

APPLICATIONS

Sonet/SDH/Avionics/High rel. clocks

Function	DFN 14	DFN 4
NC/Enable	1	1
GND	7	4
Output	8	5
Vcc	14	8

DFN 14

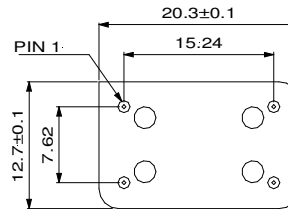

DFN 4

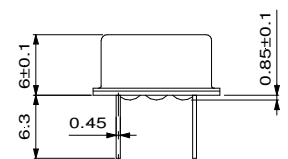
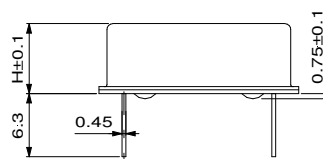
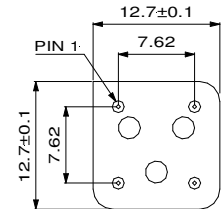

H = 5.10 mm

TYPE	DFN 14-KB	DFN 4-KB	DFN 4-KH
Frequency Range	1 to 70 MHz	1 to 70 MHz	1 to 70 MHz

ELECTRICAL SPECIFICATIONS							
supply voltage		5 V ± 5 %		5 V ± 5 %			
supply current (no load)	≤ 25 MHz > 25 MHz	≤ 20 mA ≤ 50 mA		≤ 20 mA ≤ 50 mA			
output load		HCMOS 15 pF or 10 TTL		HCMOS 50 pF up to 25 MHz, 15 pF above			
duty cycle		40/60...60/40 % @ 50% level or 1.4 V		40/60...60/40 % @ 50% level			
rise/fall times	0.4 to 2.4 V 10 to 90%	≤ 3.5 ns ≤ 5 ns 1 to 70 MHz		≤ 7 ns up to 25 MHz ≤ 3 ns > 25 MHz			
high/low levels		≥ 4.5 V / ≤ 0.5 V		≥ 4.5 V / ≤ 0.5 V			
start up		≤ 10 ms @ 4.75 V		≤ 10 ms @ 4.75 V			

FREQUENCY STABILITY		stability [ppm] and temperature code					
types	temperature range	stability	code	stability	code	stability	code
all types	0 to 70°C	≤ ± 15	XB15	≤ ± 25	XB25	≤ ± 50	XB50
	-40 to 85°C	≤ ± 25	XE25	≤ ± 50	XE50	≤ ± 75	XE75
	-55 to 125°C	≤ ± 50	XH50	≤ ± 75	XH75	≤ ± 100	XH100
remarks	XH codes only available as DFN 14/4-KB type for F ≤ 50 MHz includes calibration at 25°C, temperature, ageing, Vcc and load changes 1 st year						

OPTIONS	CODE	
tight symmetry (f ≤ 50 MHz)	R	45/55...55/45 %
tri-state output on pin 1	Z	high or open = enable, low = high Z (DFN 4-KH up to 50 MHz only)

ORDERING CODE	type + option code + frequency + temperature code
Example	DFN 4-KBZ 50.000 MHz XB15

GENERIC ORDERING CODES

SOME EXAMPLES												
TYPE	1	2	3	4	5	6	FREQUENCY	7	8	9	10	11
PXO	DFN	1	14	-	K	H	Z	68.736 MHz		X	H	100
VCXO	DFV		14	-	K	H		32.768 MHz	100	A	B	25
TCXO	DFA		S7	-	K	O	A	16.384 MHz			C	1
VC-TCXO	DFAV		36	-	M	H		10.000 MHz	40		C	2
												/12

1. TYPE CODE	2. VERSION	3. PACKAGE CODE				4. INTERNAL CODE	5. OUTPUT CODE
		Through hole		Surface mount			
DFN = CXO/PXO DFV = VCXO DFA = TCXO DFO = OCXO DFAV = VC-TCXO DFT = FCXO	model no. not for customer use	14 = DIL 14 4 = DIL 8 20 = 20 x 20 mm 36 = 36 x 27 mm	S1 = epoxy S2 = epoxy S3 = epoxy S4 = epoxy S5 = plastic S7 = epoxy S8 = epoxy S10 = ceramic S11 = ceramic S13 = epoxy S15 = ceramic S16 = ceramic S17 = ceramic	14 x 9 mm 7 x 5 mm 9 x 7 mm 24 x 22 mm 14 x 9 mm 20 x 12 mm 20 x 12 mm 14 x 9 mm 7 x 5 mm 11 x 9 mm 5 x 3.2 mm 3.2 x 2.5 mm 2.5 x 2 mm	not for customer use	T = TTL H = HCMOS B = TTL & HCMOS E = Negative ECL 10KH EC = Pos. ECL 10KH/100K LEC = LVPECL 100K L = LVDS O = Clipped square wave S = Sine wave	

6. OPTION CODE (IF NEEDED)	7. PULLING RANGE CODE	8. INDICATION CODE		9. TEMPERATURE RANGE	
		General	VCXO		
Z = tri-state L = low power model R = tight symmetry P = complimentary outputs G = inverted pin-out T = external trimmer A = internal trimmer V = external control voltage Y = external potentiometer I = enable/disable	value in ppm	X = overall frequency stability 1 year or long term ageing code void = temperature stability only	A= 0.5 to 4.5 V range center @ 2.5 V (only DIL-14) C= 0.5 to 10 V range center @ 4.25 V D= 0.3 to 3.0 V range center @ 1.65 V void = standard spec	A = 0 to 50°C L = 0 to 60°C B = 0 to 70°C M = -10 to 50°C D = -10 to 60°C I = -10 to 70°C Q = -20 to 60°C C = -20 to 70°C P = -25 to 75°C	K = -30 to 60°C R = -30 to 70°C N = -30 to 75°C T = -30 to 85°C F = -40 to 70°C E = -40 to 85°C G = -55 to 105°C H = -55 to 125°C

10. FREQUENCY STABILITY	11. SUPPLY VOLTAGE / LONG TERM AGEING CODE
frequency stability expressed in ppm, either as an overall tolerance or as temperature stability only.	indicates the supply voltage value in Volts for models offering different options of supply voltage for (VC)-TCXO indicates long term ageing for surface mount PXO

NON-STANDARD SPECIFICATIONS

Specifications that cannot be covered by the above codes will be issued a unique specification number

FORDAHL SMD PRODUCTS : TAPE & REEL DIMENSIONS

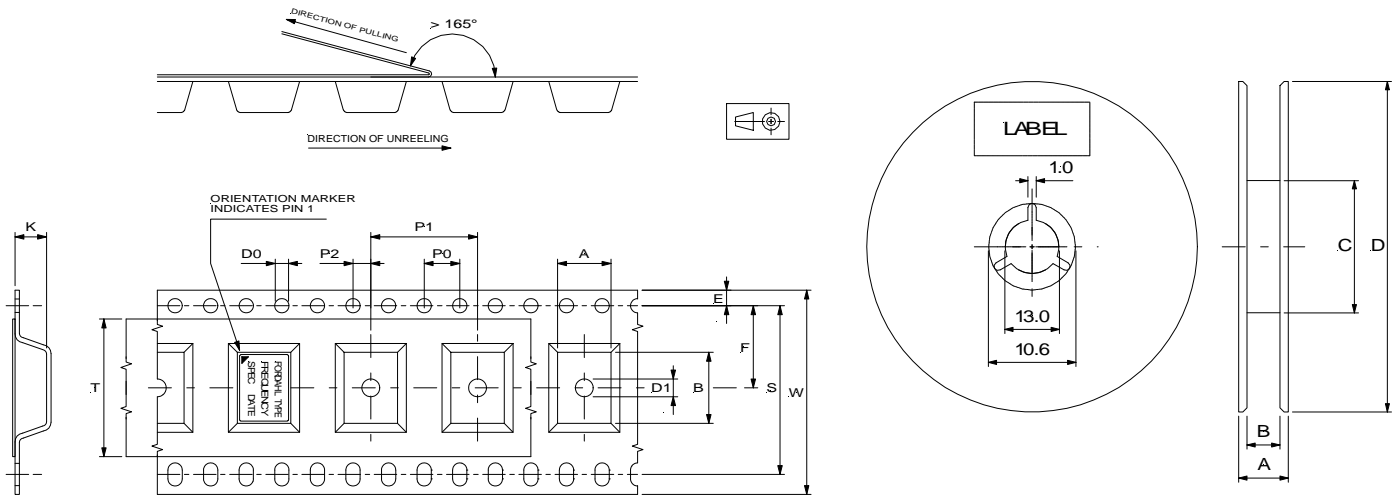

Materials:	Carrier tape	: conductive polycarbonate
	Cover tape	: polyester, antistatic coated
	Reel	: conductive or antistatic treated polystyrene

Product type	Oscil.	Tape [mm]													MOQ [pcs]	Reel [mm]			
		A	B	E	F	K	S	T	W	D0	D1	P0	P1	P2		A	B	C	D
S1	PXO VCXO TCXO	9.4	15	1.75	11.5	6.25	-	21.3	24	1.55	2.0	4.0	12	250	27.8	24.7	60	180	
																			1000
S2	PXO VCXO TCXO	5.5	8.7		7.5	3.6	-	13.3	16		1.5		8	250	19.8	16.7	60	180	
																			2000
S4	TCXO	26.5	26.5		20.2	7.5	40.4	37.5	44		1.0		32	250	49.6	45.2	100	330	
S7	VCXO	13.2	20.2		14.2	9.5	28.4	25.3	32		2.0		24	250	39.6	35.2	100	330	
	TCXO					8.0							20						450
S8	PXO	13.2	20.2		14.2	5.3	28.4	25.3	32		2.0		20	600	39.6	35.2	100	330	
														250					

Please consult factory for details on S5, S11, S15, S16 and S17

NOTICE

1. Storage

Please store the products in room where temperature / humidity is stable. Conditions should be:

Temperature : 5 to 35°C
Humidity : 30 to 60% RH

If products are stored for more than a year, solderability may be degraded. Please confirm it regularly.

2. Transportation

If you transport the products, please pack them so that the package will not be damaged by mechanical vibration / shock and please educate and guide a carrier to prevent rough handling.

RoHS SMD PRODUCTS SOLDERING GUIDELINES

1. WASHING CONDITIONS

Our non hermetic SMD products are strictly non-washable as liquid cleaning solutions could penetrate the base to cap seal. No-washing type flux with no washing is highly recommended. Please consult factory for any other process.

2. REFLOW SOLDERING CONDITIONS

Reflow profile:

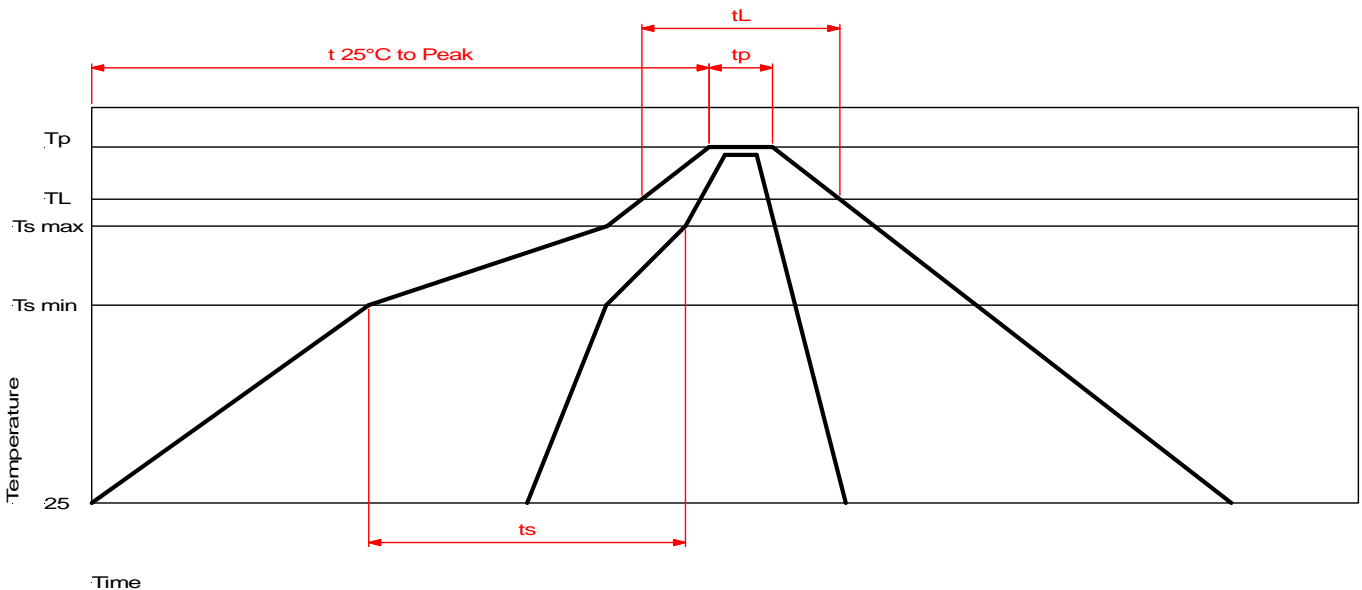

PROFILE DATA		
Minimum preheat temperature	Ts min	150°C
Maximum preheat temperature	Ts max	200°C
Preheat time	Ts min to TS max	90 - 180 seconds
Average ramp-up rate	Ts max to Tp	3°C/second max.
Reflow temperature	TL	217°C
Reflow time	tL	60 - 150 seconds
Peak temperature	TP	According to Jedec J-STD-020C
Peak time	tp	20 - 40 seconds
Average down ramp rate		6°C/seconds max.
Time 25°C to peak temperature		8 min max.

This profile is applicable for the following packages: S1, S2, S3, S4, S5, S7, S8, S11, S13, and S15

Additional recommendations:

- do not vibrate during reflow soldering
- do not reflow solder on back side
- Only one reflow is allowed
- solder adhesion may vary depending on the motherboard's thermal capacity and other factors

Hand soldering (not recommended):

Maximum temperature: 300°C/5 sec, fine tipped soldering iron