

Document No.	853-0013
ECN No.	86487
Date of Issue	November 11, 1986
Status	Product Specification
Memory Products	

82HS321 82HS321A 82HS321B

32K-bit TTL bipolar PROM

DESCRIPTION

The 82HS321, 82HS321A and 82HS321B are field-programmable, which means that custom patterns are immediately available by following the Signetics Generic II fusing procedure. The 82HS321 devices are supplied with all outputs at logical High. Outputs are programmed to a logic Low level at any specified address by fusing a programmable matrix.

These devices include on-chip decoding and 2 Chip Enable inputs for ease of memory expansion. They feature 3-State outputs for optimization of word expansion in bused organizations.

Ordering information can be found on the following page.

These devices are also processed to military requirements for operation over the military temperature range. For specifications and ordering information consult the Signetics Military Data Handbook.

FEATURES

- Address access time:
 - N82HS321: 45ns max
 - N82HS321A: 35ns max
 - N82HS321B: 30ns max
- Power dissipation: 20μW/bit typ
- Input loading: -250μA max
- Two Chip Enable inputs
- On-chip address decoding
- No separate fusing pins
- Unprogrammed outputs are High level
- Fully TTL compatible
- Outputs: 3-State

APPLICATIONS

- Prototyping/volume production
- Sequential controllers
- Microprogramming
- Hardwired algorithms
- Control store
- Random logic
- Code conversion

PIN CONFIGURATIONS

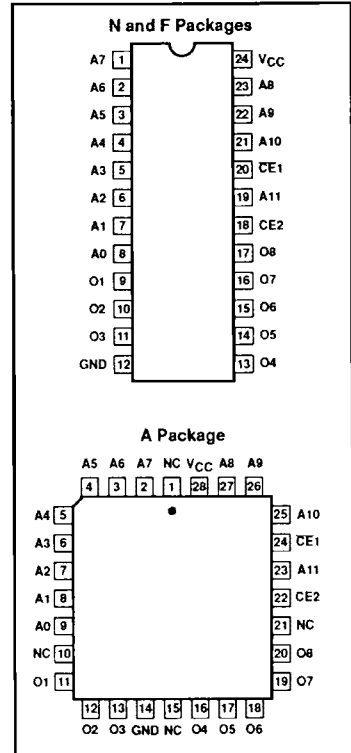

BLOCK DIAGRAM

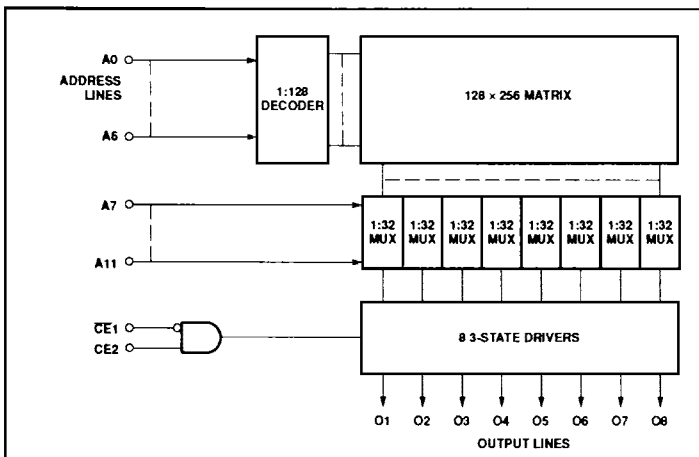

32K-bit TTL bipolar PROM (4096 × 8)

82HS321 / 82HS321A / 82HS321B

ORDERING INFORMATION

DESCRIPTION	ORDER CODE
24-Pin Plastic Dual-In-Line 600mil-wide	N82HS321 N, N82HS321A N, N82HS321B N
24-Pin Ceramic Dual-In-Line 600mil-wide	N82HS321 F, N82HS321A F, N82HS321B F
28-Pin Plastic Leaded Chip Carrier 450mil-square	N82HS321 A, N82HS321A A, N82HS321B A

ABSOLUTE MAXIMUM RATINGS

SYMBOL	PARAMETER	RATING	UNIT
V_{CC}	Supply voltage	+7.0	V_{DC}
V_{IN}	Input voltage	+5.5	V_{DC}
V_O	Output voltage Off-State	+5.5	V_{DC}
T_{amb}	Operating temperature range	0 to +75	°C
T_{stg}	Storage temperature range	-65 to +150	°C

DC ELECTRICAL CHARACTERISTICS

 $0^{\circ}\text{C} \leq T_{amb} \leq +75^{\circ}\text{C}$, $4.75\text{V} \leq V_{CC} \leq 5.25\text{V}$

SYMBOL	PARAMETER	TEST CONDITIONS ^{1,2}	LIMITS			UNIT	
			Min	Typ ³	Max		
Input voltage							
V_{IL}	Low ⁴	$I_{IN} = -18\text{mA}$	2.0		0.8	V	
V_{IH}	High ⁴					V	
V_{IC}	Clamp					V	
Output voltage							
V_{OL}	Low	$CE1 = \text{Low}, CE2 = \text{High}$ $I_{OUT} = 16\text{mA}$ $I_{OUT} = -2.0\text{mA}$	2.4		0.5	V	
V_{OH}	High					V	
Input current							
I_{IL}	Low	$V_{IN} = 0.45\text{V}$ $V_{IN} = 5.25\text{V}$				μA	
I_{IH}	High					μA	
Output current							
I_{OZ}	Hi-Z state	$CE1 = \text{High}, CE2 = \text{Low}, V_{OUT} = 0.5\text{V}$ $CE1 = \text{High}, CE2 = \text{Low}, V_{OUT} = 5.25\text{V}$ $CE1 = \text{Low}, CE2 = \text{High}, V_{OUT} = 0\text{V}$	-15		-40	μA	
I_{OS}	Short circuit ⁵					40	μA
						-70	mA
Supply current⁶							
I_{CC}		$V_{CC} = 5.25\text{V}$		130	175	mA	
Capacitance							
C_{IN}	Input	$CE1 = \text{High}, CE2 = \text{Low}, V_{CC} = 5.0\text{V}$ $V_{IN} = 2.0\text{V}$ $V_{OUT} = 2.0\text{V}$			5	pF	
C_{OUT}	Output					8	pF

NOTES:

- Positive current is defined as into the terminal referenced.
- All voltages are with respect to network ground.
- Typical values are at $V_{CC} = 5\text{V}$, $T_{amb} = +25^{\circ}\text{C}$.
- Measured with one output switching from a Logic "1" to a Logic "0".
- Duration of the short circuit should not exceed 1 second.
- Measured with all inputs grounded and all outputs open.

32K-bit TTL bipolar PROM (4096 × 8)

82HS321 / 82HS321A / 82HS321B

AC ELECTRICAL CHARACTERISTICS

$R_1 = 270\Omega$, $R_2 = 600\Omega$, $C_L = 30\text{pF}$, $0^\circ\text{C} \leq T_{\text{amb}} \leq +75^\circ\text{C}$, $4.75\text{V} \leq V_{\text{CC}} \leq 5.25\text{V}$

SYMBOL	PARAMETER	TO	FROM	N82HS321			N82HS321A			N82HS321B			UNIT
				Min	Typ ¹	Max	Min	Typ ¹	Max	Min	Typ ¹	Max	
Access time²													
t_{AA}		Output	Address		40	45		30	35		25	30	ns
t_{CE}		Output	Chip Enable		25	30		20	25		18	20	ns
Disable time³													
t_{CD}		Output	Chip Disable		25	30		20	25		18	20	ns

NOTES:

1. Typical values are $V_{\text{CC}} = 5\text{V}$, $T_{\text{amb}} = +25^\circ\text{C}$.
2. Tested at an address cycle time of $1\mu\text{s}$.
3. Measured at a delta of 0.5V from Logic Level with $R_1 = 750\Omega$, $R_2 = 750\Omega$ and $C_L = 5\text{pF}$.

TEST LOAD CIRCUIT

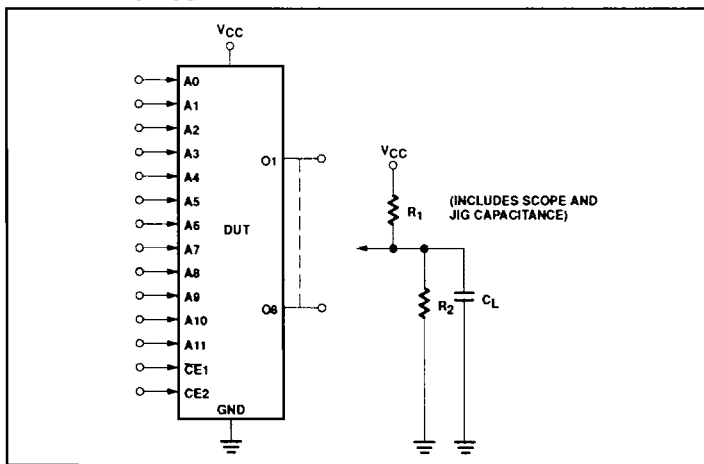

VOLTAGE WAVEFORM

