Features

- 80C51 Compatible
 - Three I/O Ports
 - Two 16-bit Timer/Counters
 - 256 Bytes RAM
- 4K Bytes ROM/OTP Program Memory with 64 Bytes Encryption Array and 3 Security Levels
- High-Speed Architecture
 - 33 MHz at 5V (66 MHz Equivalent)
 - 20 MHz at 3V (40 MHz Equivalent)
 - X2 Speed Improvement Capability (6 Clocks/Machine Cycle)
- 10-bit, 8 Channels A/D Converter
- Hardware Watchdog Timer
- Programmable I/O Mode: Standard C51, Input Only, Push-pull, Open Drain
- Asynchronous Port Reset
- Full Duplex Enhanced UART with Baud Rate Generator
- SPI, Master Mode
- Dual System Clock
 - Crystal or Ceramic Oscillator (33/40 MHz)
 - Internal RC Oscillator (12 MHz)
 - Programmable Prescaler
- Programmable Counter Array with High-speed Output, Compare/Capture, Pulse Width Modulation and Watchdog Timer Capabilities
- Interrupt Structure
 - 8 Interrupt Sources
 - 4 Interrupt Priority Levels
- Power Control Modes
 - Idle Mode
 - Power-down Mode
 - Power-off Flag
- Power Supply: 2.7 - 5.5V
- Temperature Range: Industrial (-40 to 85°C)
- Package: SO24, DIL24, SSOP24

Description

The AT8xC5111 is a high-performance ROM/OTP version of the 80C51 8-bit microcontroller in low pin count package.

The AT8xC5111 retains all the features of the standard 80C51 with 4K Bytes ROM/OTP program memory, 256 bytes of internal RAM, an 8-source, 4-level interrupt system, an on-chip oscillator and two timer/counters.

The AT8xC5111 is dedicated for analog interfacing applications. For this, it has a 10-bit, 8 channels A/D converter and a five-channel Programmable Counter Array.

In addition, the AT8xC5111 has a Hardware Watchdog Timer, a versatile serial channel that facilitates multiprocessor communication (EUSART) with an independent baud rate generator, an SPI serial bus controller and a X2 speed improvement mechanism. The X2 feature permits keeping the same CPU power at an oscillator frequency divided by two. The prescaler allows to decrease CPU and peripherals clock frequency.

The fully static design of the AT8xC5111 can reduce system power consumption by bringing the clock frequency down to any value, even DC, without loss of data.

The AT8xC5111 has 3 software-selectable modes of reduced activity for further reduction in power consumption. In the idle mode, the CPU is frozen while the peripherals are still operating. In the quiet mode, only the A/D converter is operating.



Low Pin Count 8-bit Microcontroller with A/D Converter

AT83C5111
AT87C5111

Rev. 4190B-8051-02/08



In the power-down mode, the RAM is saved and all other functions are inoperative. Two oscillator sources, crystal and RC, provide a versatile power management.

The AT8xC5111 is proposed in low-pin count packages. Port 0 and Port 2 (address/data buses) are not available .

Block Diagram

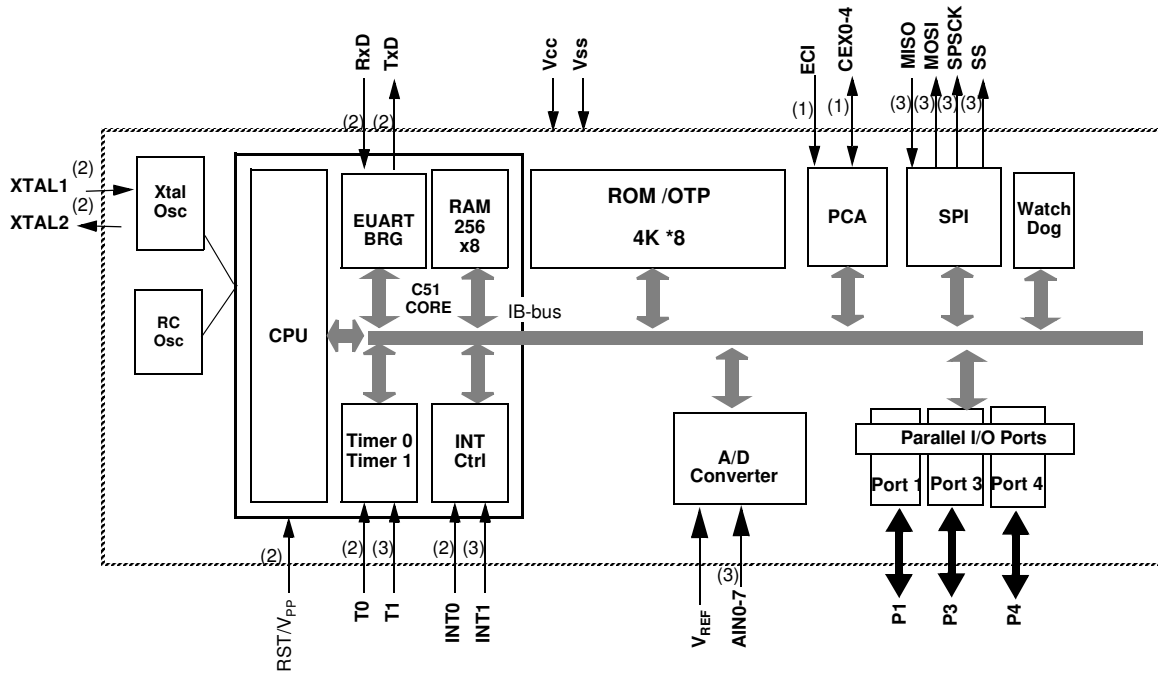

- Notes:
1. Alternate function of Port 1.
 2. Alternate function of Port 3.
 3. Alternate function of Port 4.

SFR Mapping

The Special Function Registers (SFRs) of the AT8xC5111 belong to the following categories:

- C51 core registers: ACC, B, DPH, DPL, PSW, SP, AUXR1
- I/O port registers: P1, P3, P4, P1M1, P1M2, P3M1, P3M2, P4M1, P4M2
- Timer registers: TCON, TH0, TH1, TMOD, TL0, TL1
- Serial I/O port registers: SADDR, SADEN, SBUF, SCON, BRL, BDRCON
- Power and clock control registers: CKCON0, CKCON1, OSCCON, CKSEL, PCON, CKRL
- Interrupt system registers: IE, IE1, IPL0, IPL1, IPH0, IPH1
- Watchdog Timer: WDTRST, WDTPRG
- SPI: SPCON, SPSTA, SPDAT
- PCA: CCAP0L, CCAP1L, CCAP2L, CCAP3L, CCAP4L, CCAP0H, CCAP1H, CCAP2H, CCAP3H, CCAP4H, CCAPM0, CCAPM1, CCAPM2, CCAPM3, CCAPM4, CL, CH, CMOD, CCON
- ADC: ADCCON, ADCCLK, ADCDATH, ADCDATL, ADCF

Table 1. SFR Addresses and Reset Values

	0/8	1/9	2/A	3/B	4/C	5/D	6/E	7/F	
F8h		CH 0000 0000	CCAP0H XXXX XXXX	CCAP1H XXXX XXXX	CCAP2H XXXX XXXX	CCAP3H XXXX XXXX	CCAP4H XXXX XXXX		FFh
F0h	B 0000 0000		ADCLK 0000 0000	ADCON 0000 0000	ADDL XXXXXX00	ADDH 0000 0000	ADCF 0000 0000		F7h
E8h		CL 0000 0000	CCAP0L XXXX XXXX	CCAP1L XXXX XXXX	CCAP2L XXXX XXXX	CCAP3L XXXX XXXX	CCAP4L XXXX XXXX	CONF	EFh
E0h	ACC 0000 0000		P1M2 0000 0000		P3M2 0000 0000	P4M2 0000 0000			E7h
D8h	CCON 00X0 0000	CMOD X000 0000	CCAPM0 00XX X000	CCAPM1 X000 0000	CCAPM2 X000 0000	CCAPM3 X000 0000	CCAPM4 X000 0000		DFh
D0h	PSW 0000 0000				P1M1 0000 0000	P3M1 0000 0000	P4M1 0000 0000		D7h
C8h									CFh
C0h	P4 1111 1111			SPCON 0001 0100	SPSTA XXXXXXXX	SPDAT XXXX XXXX			C7h
B8h	IPL0 0000 0000	SADEN 0000 0000							BFh
B0h	P3 1111 1111	IE1 0000 0000	IPL1 0000 0000	IPH1 0000 0000				IPH0 X000 0000	B7h
A8h	IE0 0000 0000	SADDR 0000 0000						CKCON1 XXXX XXX0	AFh
A0h			AUXR1 XXXXXXXX0				WDRST 0000 0000	WDTPRG 0000 0000	A7h
98h	SCON 0000 0000	SBUF XXXX XXXX	BRL 0000 0000	BDRCON 0000 0000					9Fh
90h	P1 1111 1111							CKRL 1111 1111	97h
88h	TCON 0000 0000	TMOD 0000 0000	TL0 0000 0000	TL1 0000 0000	TH0 0000 0000	TH1 0000 0000		CKCON0 X000X000	8Fh
80h		SP 0000 0111	DPL 0000 0000	DPH 0000 0000		CKSEL XXXX XXX1	OSCCON XXXX XX01	PCON 00X1 0000	87h
	0/8	1/9	2/A	3/B	4/C	5/D	6/E	7/F	

Reserved

Pin Configuration

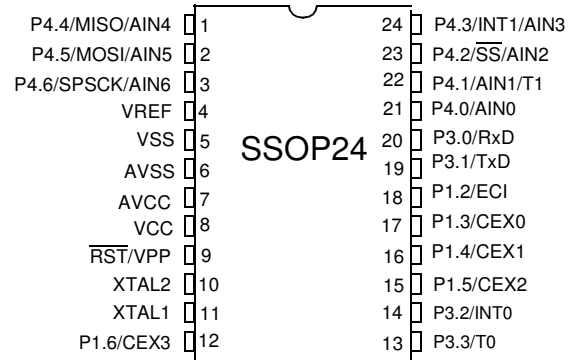
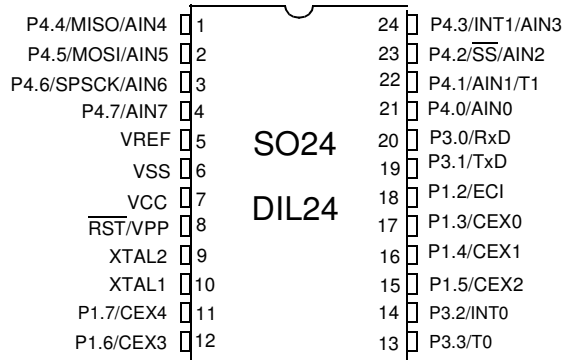

Pin Descriptions

Mnemonic	Type	Name and Function
V _{SS}	I	Ground: 0V reference
V _{CC}	I	Power Supply: This is the power supply voltage for normal, idle and power-down operation.
VREF	I	VREF: A/D converter positive reference input
RST/VPP	I	RST/V_{PP}: Reset/Programming Supply Voltage: A low on this pin for two machine cycles while the oscillator is running, resets the device. This pin has no pull-up. In order to use the internal power-on reset, an external pull-up resistor must be connected. This pin also receives the 12V programming pulse which will start the EPROM programming and the manufacturer test modes.
XTAL1	I	XTAL1 : Input to the inverting oscillator amplifier and input to the internal clock generator circuits
XTAL2	O	XTAL2 : Output from the inverting oscillator amplifier
P1.2 - P1.7	I/O	Port 1: Port 1 is an 6-bit programmable I/O port . See Section "Ports", page 18 for a description of I/O ports. Alternate functions for Port 1 include: I/O ECI (P1.2): External Clock for the PCA I/O CEX0 (P1.3): Capture/Compare External I/O for PCA module 0 I/O CEX1 (P1.4): Capture/Compare External I/O for PCA module 1 I/O CEX2 (P1.5): Capture/Compare External I/O for PCA module 2 I/O CEX3 (P1.6): Capture/Compare External I/O for PCA module 3 I/O CEX4 (P1.7): Capture/Compare External I/O for PCA module 4
P3.0 - P3.3	I/O	Port 3: Port 3 is an 6-bit programmable I/O port with internal pull-ups. See Section "Ports", page 18 for a description of I/O ports. Port 3 also serves the special features of the 80C51 family, as listed below. I/O RXD (P3.0): Serial input port I/O TXD (P3.1): Serial output port

Mnemonic	Type	Name and Function
	I/O	INT0 (P3.2): External interrupt 0
	I/O	T0 (P3.3): Timer 0 external input
P4.0 - P4.7	I/O	Port 4: Port 4 is an 8-bit programmable I/O port with internal pull-ups. See Section "Ports", page 18 for a description of I/O ports. Port 4 is also the input port of the analog-to-digital converter.
	I/O	AIN0 (P4.0): A/D converter input 0
	I/O	AIN1 (P4.1): A/D converter input 1 T1: Timer 1 external input
	I/O	AIN2 (P4.2): A/D converter input 2 SS: Slave select input of the SPI controllers
	I/O	AIN3 (P4.3): A/D converter input 3 INT1: External interrupt 1
	I/O	AIN4 (P4.4): A/D converter input 4 MISO: Master IN, Slave OUT of the SPI controllers
	I/O	AIN5 (P4.5): A/D converter input 5 MOSI: Master OUT, Slave IN of the SPI controllers
	I/O	AIN6 (P4.6): A/D converter input 6 SPSCK: Clock I/O of the SPI controllers
	I/O	AIN7 (P4.7): A/D converter input 7

Clock System

The AT8xC5111 oscillator system provides a reliable clocking system with full mastering of speed versus CPU power trade off. Several clock sources are possible:

- External clock input
- High-speed crystal or ceramic oscillator
- Integrated high-speed RC oscillator

The selected clock source can be divided by 2 - 512 before clocking the CPU and the peripherals. When X2 function is set, the CPU needs 6 clock periods per cycle.

Clocking is controlled by several SFR registers: OSCON, CKCON0, CKCON1, CKRL.

Blocks Description

The AT8xC5111 includes the following oscillators:

- Crystal oscillator
- Integrated high-speed RC oscillator, with typical frequency of 12 MHz

Crystal Oscillator: OSCA

The crystal oscillator uses two external pins, XTAL1 for input and XTAL2 for output.

Both crystal and ceramic resonators can be used. An oscillator source on XTAL1 is mandatory to start the product.

OSCAEN in OSCCON register is an enable signal for the crystal oscillator or the external oscillator input.

Integrated High-speed RC Oscillator: OSCB

The high-speed RC oscillator typical frequency is 12 MHz. Note that the on chip oscillator has a $\pm 50\%$ frequency tolerance and may not be suitable for use in some applications.

OSCBEN in OSCCON register is an enable signal for the high-speed RC oscillator.

Clock Selector

CKS bit in CKS register is used to select from crystal to RC oscillator.

OSCBEN bit in OSCCON register is used to enable the RC oscillator.

OSCAEN bit in OSCCON register is used to enable the crystal oscillator or the external oscillator input.

Clock Prescaler

Before supplying the CPU and the peripherals, the main clock is divided by a factor of 2 to 512, as defined by the CKRL register. The CPU needs from 12 to 256×12 clock periods per instruction. This allows:

- to accept any cyclic ratio to be accepted on XTAL1 input.
- to reduce the CPU power consumption.

The X2 bit allows to bypass the clock prescaler; in this case, the CPU needs only 6 clock periods per machine cycle. In X2 mode, as this divider is bypassed, the signals on XTAL1 must have a cyclic ratio between 40 to 60%.

Functional Block Diagram

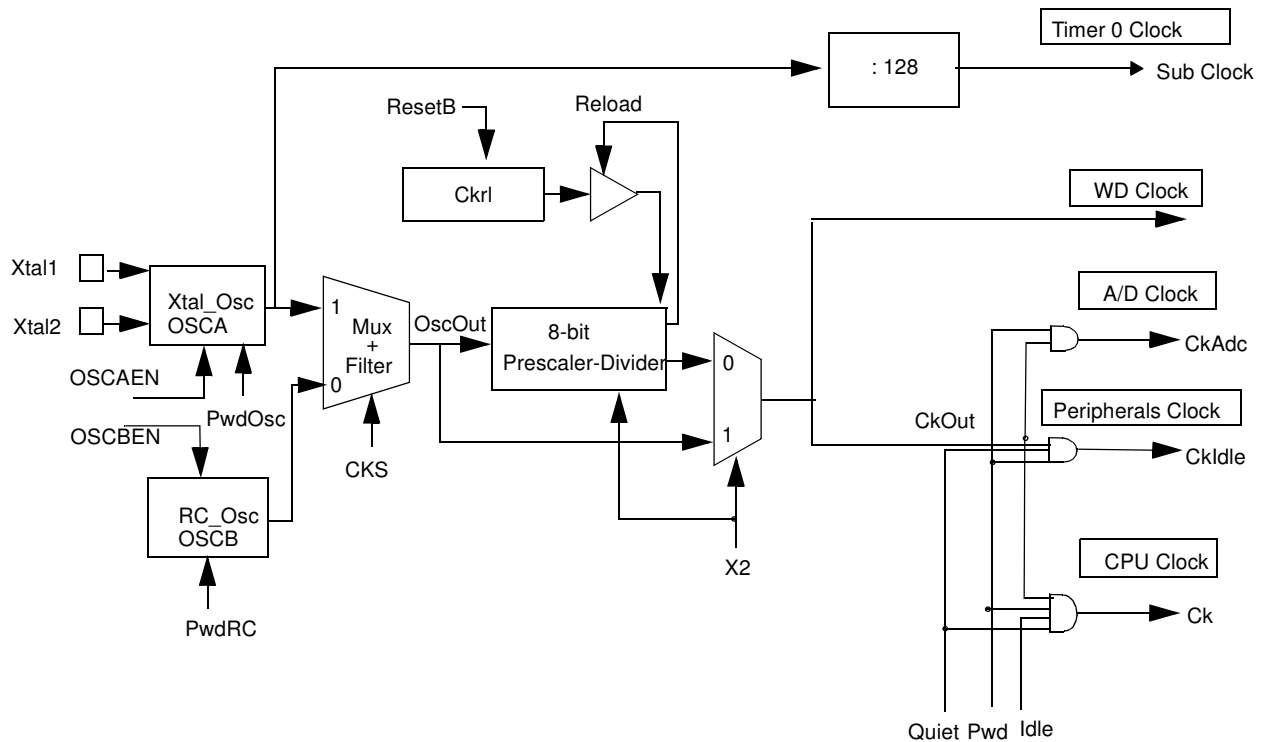

Operating Modes

Functional Modes

Normal Modes

- CPU and Peripheral clocks depend on the software selection using CKCON0, CKCON1, CKSEL and CKRL registers.
- CKS bit selects either Xtal_Osc or RC_Osc.
- CKRL register determines the frequency of the selected clock, unless X2 bit is set. In this case the prescaler/divider is not used, so CPU core needs only 6 clock periods per machine cycle. According to the value of the peripheral X2 individual bit, each peripheral needs 6 or 12 clock periods per instruction.
- It is always possible to switch dynamically by software from Xtal_Osc to RC_Osc, and vice versa by changing CKS bit, a synchronization cell allowing to avoid any spike during transition.

Idle Modes

- IDLE modes are achieved by using any instruction that writes into PCON.0 sfr
- IDLE modes A and B depend on previous software sequence, prior to writing into PCON.0 register:
 - IDLE MODE A: Xtal_Osc is running (OSCAEN = 1) and selected (CKS = 1)
 - IDLE MODE B: RC_Osc is running (OSCBEN = 1) and selected (CKS = 0)
- The unused oscillator Xtal_Osc or RC_Osc can be stopped by software by clearing OSCAEN or OSCBEN, respectively.
- Exit from IDLE mode is achieved by Reset, or by activation of an enabled interrupt.
- In both cases, PCON.0 is cleared by hardware.

Power-down Modes

- Exit from IDLE modes will leave the oscillator control bits OSCAEN, OSCBEN and CKS unchanged.
- POWER-DOWN modes are achieved by using any instruction that writes into PCON.1 sfr
- Exit from POWER-DOWN mode is achieved either by a hardware Reset, or by an external interruption.
- By RST signal: The CPU will restart on OSCA.
- By INT0 or INT1 interruptions, if enabled. The oscillators control bits OSCAEN, OSCBEN and CKS will not be changed, so the selected oscillator before entering into Power-down will be activated.

Table 1. Power Modes

PD	IDLE	CKS	OSCBEN	OSCAEN	Selected Mode	Comment
0	0	1	X	1	NORMAL MODE A	OSCA: XTAL clock
X	X	1	X	0	INVALID	No active clock
0	0	0	1	X	NORMAL MODE B	OSCB: high-speed RC clock
X	X	0	0	X	INVALID	
0	1	1	X	1	IDLE MODE A	The CPU is off, OSCA supplies the peripherals
0	1	0	1	X	IDLE MODE B	The CPU is off, OSCB supplies the peripherals
1	X	X	X	X	TOTAL POWER-DOWN	The CPU is off, OSCA and OSCB are stopped

Prescaler Divider

- An hardware RESET selects the prescaler divider:
 - CKRL = FFh: internal clock = OscOut/2 (Standard C51 feature)
 - X2 = 0,
- After Reset, any value between FFh down to 00h can be written by software into CKRL sfr in order to divide frequency of the selected oscillator:
 - CKRL = 00h: minimum frequency = OscOut/512
 - CKRL = FFh: maximum frequency = OscOut/2

The frequency of the CPU and peripherals clock CkOut is related to the frequency of the main oscillator OscOut by the following formula:

$$F_{CkOut} = F_{OscOut} / (512 - 2 * CKRL)$$

Some examples can be found in the table below:

F _{OscOut} MHz	X2	CKRL	F _{CkOut} (Mhz)
12	0	FF	6
12	0	FE	3
12	1	x	12

- A software instruction which sets X2 bit de-activates the prescaler/divider, so the internal clock is either Xtal_Osc or RC_Osc depending on SEL_OSC bit.

Timer 0: Clock Inputs

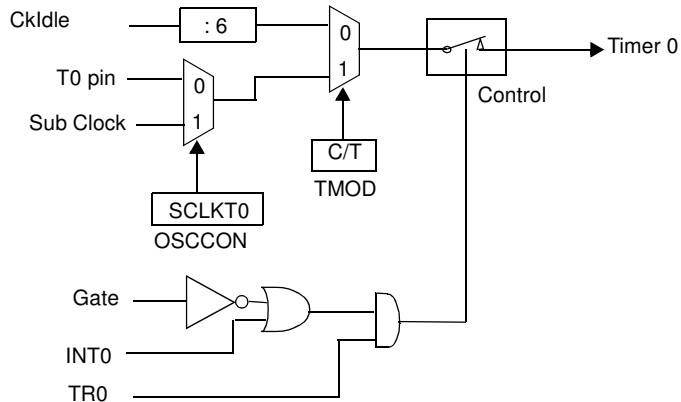

The SCLKT0 bit in OSCCON register allows to select Timer 0 Subsidiary clock. This allows to perform a Real-Time Clock function.

SCLKT0 = 0: Timer 0 uses the standard T0 pin as clock input (Standard mode).

SCLKT0 = 1: Timer 0 uses the special Sub Clock as clock input.

When the subclock input is selected for Timer 0 and the crystal oscillator is selected for CPU and peripherals, the CKRL prescaler must be set to FF (division factor 2) in order to assure a proper count on Timer 0.

With an external a 32 kHz oscillator, the timer interrupt can be set from 1/256 to 256 seconds to perform a Real-Time Clock (RTC) function. The power consumption will be very low as the CPU is in idle mode at 32 kHz most of the time. When more CPU power is needed, the internal RC oscillator is activated and used by the CPU and the others peripherals.

Registers

Clock Control Register

The clock control register is used to define the clock system behavior.

Table 2. OSCCON - Clock Control Register (8Fh)

7	6	5	4	3	2	1	0
-	-	-	-	-	SCLKT0	OSCBEN	OSCAEN
Bit Number	Bit Mnemonic	Description					
7	-	Reserved The value read from this bit is indeterminate. Do not set this bit.					
6	-	Reserved The value read from this bit is indeterminate. Do not set this bit.					
5	-	Reserved The value read from this bit is indeterminate. Do not set this bit.					
4	-	Reserved The value read from this bit is indeterminate. Do not set this bit.					
3	-	Reserved The value read from this bit is indeterminate. Do not set this bit.					

Bit Number	Bit Mnemonic	Description
2	SCLKT0	Sub Clock Timer0 Cleared by software to select T0 pin Set by software to select T0 Sub Clock
1	OSCBEN	Enable RC oscillator This bit is used to enable the high-speed RC oscillator 0: The oscillator is disabled 1: The oscillator is enabled.
0	OSCAEN	Enable crystal oscillator This bit is used to enable the crystal oscillator 0: The oscillator is disabled 1: The oscillator is enabled.

Reset value = 0XXX X001b

Not bit addressable

Clock Selection Register

The clock selection register is used to define the clock system behavior

Table 3. CKSEL - Clock Selection Register (85h)

7	6	5	4	3	2	1	0
	-	-	-	-	-	-	CKS

Bit Number	Bit Mnemonic	Description
7	-	Reserved The value read from this bit is indeterminate. Do not set this bit.
6	-	Reserved The value read from this bit is indeterminate. Do not set this bit.
5	-	Reserved The value read from this bit is indeterminate. Do not set this bit.
4	-	Reserved The value read from this bit is indeterminate. Do not set this bit.
3	-	Reserved The value read from this bit is indeterminate. Do not set this bit.
2	-	Reserved The value read from this bit is indeterminate. Do not set this bit.
1	-	Reserved The value read from this bit is indeterminate. Do not set this bit.
0	CKS	Active oscillator selection This bit is used to select the active oscillator. 1: The crystal oscillator is selected. 0: The high-speed RC oscillator is selected.

Reset value = XXXX XXX 1 b

Not bit addressable

Clock Prescaler Register

This register is used to reload the clock prescaler of the CPU and peripheral clock.

Table 4. CKRL - Clock Prescaler Register (97h)

7	6	5	4	3	2	1	0
M							
Bit Number	Bit Mnemonic	Description					
7: 0	CKRL	0000 0000b: Division factor equal 512 1111 1111b: Division factor equal 2 M: Division factor equal $2^{*(256-M)}$					

Reset value = 1111 1111b

Not bit addressable

Clock Control Register

This register is used to control the X2 mode of the CPU and peripheral clock.

Table 5. CKCON0 Register (8Fh)

7	6	5	4	3	2	1	0
-	WdX2	PcaX2	SiX2	-	T1X2	T0X2	X2
Bit Number	Bit Mnemonic	Description					
7	-	Reserved					
6	WdX2	Watchdog clock (This control bit is validated when the CPU clock X2 is set; when X2 is low, this bit has no effect) Clear to select 6 clock periods per peripheral clock cycle. Set to select 12 clock periods per peripheral clock cycle.					
5	PcaX2	Programmable Counter Array clock (This control bit is validated when the CPU clock X2 is set; when X2 is low, this bit has no effect) Clear to select 6 clock periods per peripheral clock cycle. Set to select 12 clock periods per peripheral clock cycle.					
4	SiX2	Enhanced UART clock (Mode 0 and 2) (This control bit is validated when the CPU clock X2 is set; when X2 is low, this bit has no effect) Clear to select 6 clock periods per peripheral clock cycle. Set to select 12 clock periods per peripheral clock cycle.					
3	-	Reserved					
2	T1X2	Timer 1 clock (This control bit is validated when the CPU clock X2 is set; when X2 is low, this bit has no effect) Clear to select 6 clock periods per peripheral clock cycle. Set to select 12 clock periods per peripheral clock cycle					
1	T0X2	Timer 0 clock (This control bit is validated when the CPU clock X2 is set; when X2 is low, this bit has no effect) Clear to select 6 clock periods per peripheral clock cycle. Set to select 12 clock periods per peripheral clock cycle.					

Bit Number	Bit Mnemonic	Description
0	X2	CPU clock Clear to select 12 clock periods per machine cycle (STD mode) for CPU and all the peripherals. Set to select 6clock periods per machine cycle (X2 mode) and to enable the individual peripherals "X2" bits.

Reset value = X000 0000b

Not bit addressable

Table 6. CKCON1 Register (AFh)

7	6	5	4	3	2	1	0
-	-	-	-	-	-	BRGX2	SPIX2

Bit Number	Bit Mnemonic	Description
7	-	Reserved
6	-	Reserved
5	-	Reserved
4	-	Reserved
3	-	Reserved
2	-	Reserved
1	BRGX2	BRG clock (This control bit is validated when the CPU clock X2 is set; when X2 is low, this bit has no effect). Clear to select 6 clock periods per peripheral clock cycle. Set to select 12 clock periods per peripheral clock cycle.
0	SPIX2	SPI clock (This control bit is validated when the CPU clock X2 is set; when X2 is low, this bit has no effect) Clear to select 6 clock periods per peripheral clock cycle. Set to select 12 clock periods per peripheral clock cycle.

Reset value = XXXX XX00b

Not bit addressable

Reset and Power Management

The power monitoring and management can be used to supervise the Power Supply (V_{DD}) and to start up properly when AT8xC5111 is powered up.

It consists of the features listed below and explained hereafter:

- Power-off flag
- Idle mode
- Power-down mode
- Reduced EMI mode

All these features are controlled by several registers, the Power Control register (PCON) and the Auxiliary register (AUXR) detailed at the end of this section.

AUX register not available on all versions.

Functional Description

Figure 1 shows the block diagram of the possible sources of microcontroller reset.

Figure 1. Reset Sources

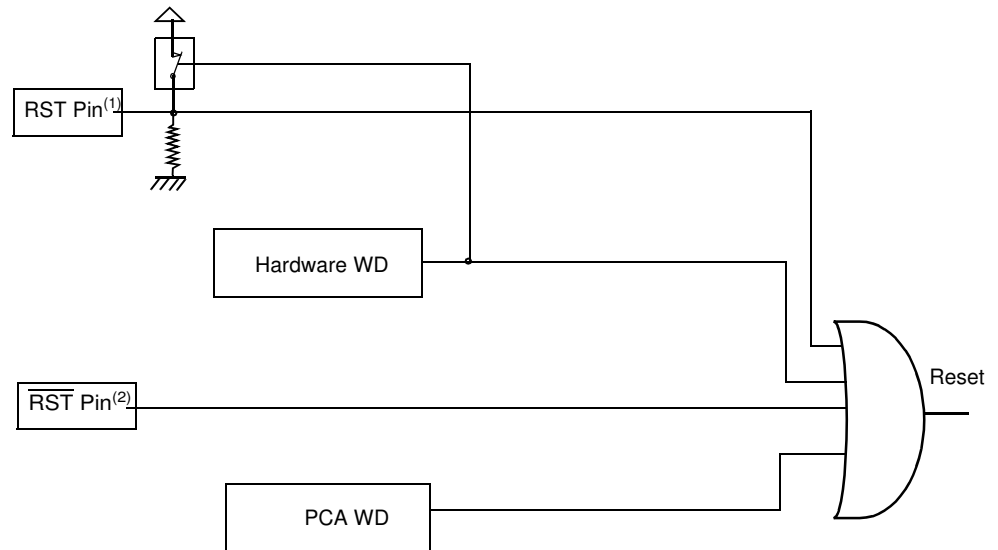

- Notes:
1. $\overline{\text{RST}}$ pin available only on 48 and 52 pins versions.
 2. $\overline{\text{RST}}$ pin available only on LPC versions.

Power-off Flag

When the power is turned off or fails, the data retention is not guaranteed. A Power-off Flag (POF, Table 8 on page 15) allows to detect this condition. POF is set by hardware during a reset which follows a power-up or a power-fail. This is a cold reset. A warm reset is an external or a watchdog reset without power failure, hence which preserves the internal memory content and POF. To use POF, test and clear this bit just after reset. Then it will be set only after a cold reset.

Registers

PCON: Power Configuration Register

Table 1. PCON Register (87h)

7	6	5	4	3	2	1	0
SMOD1	SMOD0	–	POF	GF1	GF0	PD	IDL
Bit Number	Bit Mnemonic	Description					
7	SMOD1	Double Baud Rate bit Set to double the Baud Rate when Timer 1 is used and mode 1, 2 or 3 is selected in SCON register.					
6	SMOD0	SCON Select bit When cleared, read/write accesses to SCON.7 are to SM0 bit and read/write accesses to SCON.6 are to SM1 bit. When set, read/write accesses to SCON.7 are to FE bit and read/write accesses to SCON.6 are to OVR bit. SCON is Serial Port Control register.					
5	–	Reserved Must be cleared.					
4	POF	Power-off flag Set by hardware when V_{DD} rises above V_{RET+} to indicate that the Power Supply has been set off. Must be cleared by software.					
3	GF1	General Purpose flag 1 One use is to indicate whether an interrupt occurred during normal operation or during Idle mode.					
2	GF0	General Purpose flag 0 One use is to indicate whether an interrupt occurred during normal operation or during Idle mode.					
1	PD	Power-down Mode bit Cleared by hardware when an interrupt or reset occurs. Set to activate the Power-down mode. If IDL and PD are both set, PD takes precedence.					
0	IDL	Idle Mode bit Cleared by hardware when an interrupt or reset occurs. Set to activate the Idle mode. If IDL and PD are both set, PD takes precedence.					

Reset value = 0000 0000b

Port Pins

The value of port pins in the different operating modes is shown on Table 9.

Table 2. Pin Conditions in Special Operating Modes

Mode	Program Memory	Port 1 Pins	Port 3 Pins	Port 4 Pins
Reset	Don't care	Weak High	Weak High	Weak High
Idle	Internal	Data	Data	Data
Power-down	Internal	Data	Data	Data

Hardware Watchdog Timer (WDT)

The WDT is intended as a recovery method in situations where the CPU may be subjected to software upset. The WDT consists of a 14-bit counter and the Watchdog Timer Reset (WDTRST) SFR. The WDT is by default disabled from exiting reset. To enable the WDT, the user must write 01EH and 0E1H in sequence to the WDTRST, SFR location 0A6H. When WDT is enabled, it will increment every machine cycle (6 internal clock periods) and there is no way to disable the WDT except through reset (either hardware reset or WDT overflow reset). The T0 bit of the WDTPRG register is used to select the overflow after 10 or 14 bits. When WDT overflows, it will generate an internal reset. It will also drive an output RESET HIGH pulse at the emulator RST-pin. The length of the reset pulse is 24 clock periods of the WD clock.

Using the WDT

To enable the WDT, the user must write 01EH and 0E1H in sequence to the WDTRST, SFR location 0A6H. When WDT is enabled, the user needs to service it by writing to 01EH and 0E1H to WDTRST to avoid WDT overflow. The 14-bit counter overflows when it reaches 16383 (3FFFH) or 1024 (1FFFH) and this will reset the device. When WDT is enabled, it will increment every machine cycle while the oscillator is running. This means the user must reset the WDT at least every 16383 machine cycle. To reset the WDT the user must write 01EH and 0E1H to WDTRST. WDTRST is a write only register. The WDT counter cannot be read or written. When WDT overflows, it will generate an output RESET pulse at the RST pin. The RESET pulse duration is $96 \times T_{OSC}$, where $T_{OSC} = 1/F_{OSC}$. To make the best use of the WDT, it should be serviced in those sections of code that will periodically be executed within the time required to prevent a WDT reset.

To have a more powerful WDT, a 2^7 counter has been added to extend the Time-out capability, ranking from 16 ms to 2s at $F_{OSC} = 12$ MHz and $T0 = 0$. To manage this feature, refer to WDTPRG register description, Table 11 (SFR0A7h).

Table 1. WDTRST Register

WDTRST Address (0A6h)

	7	6	5	4	3	2	1
Reset value	X	X	X	X	X	X	X

Write only, this SFR is used to reset/enable the WDT by writing 01EH then 0E1H in sequence.

Table 2. WDTPRG Register
WDTPRG Address (0A7h)

7	6	5	4	3	2	1	0
T4	T3	T2	T1	T0	S2	S1	S0
Bit Number	Bit Mnemonic	Description					
7	T4	Reserved Do not try to set this bit.					
6	T3						
5	T2						
4	T1						
3	T0	WDT overflow select bit 0: Overflow after 14 bits 1: Overflow after 10 bits					
2	S2	WDT Time-out select bit 2					
1	S1	WDT Time-out select bit 1					
0	S0	WDT Time-out select bit 0					
		S2	S1	S0	Selected Time-out with T0 = 0		
		0	0	0	$(2^{14} - 1)$ machine cycles, 16.3 ms at 12 MHz		
		0	0	1	$(2^{15} - 1)$ machine cycles, 32.7 ms at 12 MHz		
		0	1	0	$(2^{16} - 1)$ machine cycles, 65.5 ms at 12 MHz		
		0	1	1	$(2^{17} - 1)$ machine cycles, 131 ms at 12 MHz		
		1	0	0	$(2^{18} - 1)$ machine cycles, 262 ms at 12 MHz		
		1	0	1	$(2^{19} - 1)$ machine cycles, 542 ms at 12 MHz		
		1	1	0	$(2^{20} - 1)$ machine cycles, 1.05 s at 12 MHz		
		1	1	1	$(2^{21} - 1)$ machine cycles, 2.09 s at 12 MHz		

Reset value = XXX0 0000

Write only register

WDT During Power-down and Idle

Power-down

In Power-down mode the oscillator stops, which means the WDT also stops. While in Power-down mode the user does not need to service the WDT. There are 2 methods of exiting Power-down mode: by a hardware reset or via a level activated external interrupt which is enabled prior to entering Power-down mode. When Power-down is exited with hardware reset, servicing the WDT should occur as normal whenever the AT8xC5111 is reset. Exiting Power-down with an interrupt is significantly different. The interrupt is held low long enough for the oscillator to stabilize. When the interrupt is brought high, the interrupt is serviced. To prevent the WDT from resetting the device while the interrupt pin is held low, the WDT is not started until the interrupt is pulled high. It is suggested that the WDT be reset during the interrupt service routine.

To ensure that the WDT does not overflow within a few states of exiting of power-down, it is best to reset the WDT just before entering power-down.

Idle Mode

In Idle mode, the oscillator continues to run. To prevent the WDT from resetting the AT8xC5111 while in Idle mode, the user should always set up a timer that will periodically exit Idle, service the WDT, and re-enter Idle mode.

Ports

The low pin count versions of the AT8xC5111 has 3 I/O ports, port 1, port 3, and port 4.

All port1, port3 and port4 I/O port pins on the AT8xC5111 may be software configured to one of four types on a bit-by-bit basis, as shown in Table 13. These are: quasi bi-directional (standard 80C51 port outputs), push-pull, open drain, and input only. Two configuration registers for each port choose the output type for each port pin.

Table 1. Port Output Configuration Settings Using PxM1 and PxM2 Registers

PxM1.y Bit	PxM2.y Bit	Port Output Mode
0	0	Quasi bidirectional
0	1	Push-pull
1	0	Input Only (High Impedance)
1	1	Open Drain

Port Types

Quasi Bi-directional Output Configuration

The default port output configuration for standard AT8xC5111 I/O ports is the quasi bi-directional output that is common on the 80C51 and most of its derivatives. This output type can be used as both an input and output without the need to reconfigure the port. This is possible because when the port outputs a logic high, it is weakly driven, allowing an external device to pull the pin low. When the pin is pulled low, it is driven strongly and able to sink a fairly large current. These features are somewhat similar to an open drain output except that there are three pull-up transistors in the quasi-bidirectional output that serve different purposes. One of these pull-ups, called the "very weak" pull-up, is turned on whenever the port latch for the pin contains a logic 1. The very weak pull-up sources a very small current that will pull the pin high if it is left floating. A second pull-up, called the "weak" pull-up, is turned on when the port latch for the pin contains a logic 1 and the pin itself is also at a logic 1 level. This pull-up provides the primary source current for a quasi-bidirectional pin that is outputting a 1. If a pin that has a logic 1 on it is pulled low by an external device, the weak pull-up turns off, and only the very weak pull-up remains on. In order to pull the pin low under these conditions, the external device has to sink enough current to overpower the weak pull-up and take the voltage on the port pin below its input threshold.

The third pull-up is referred to as the "strong" pull-up. This pull-up is used to speed up low-to-high transitions on a quasi bi-directional port pin when the port latch changes from a logic 0 to a logic 1. When this occurs, the strong pull-up turns on for a brief time, two CPU clocks, in order to pull the port pin high quickly. Then it turns off again.

The quasi bi-directional port configuration is shown in Figure 2.

Figure 1. Quasi bi-directional Output

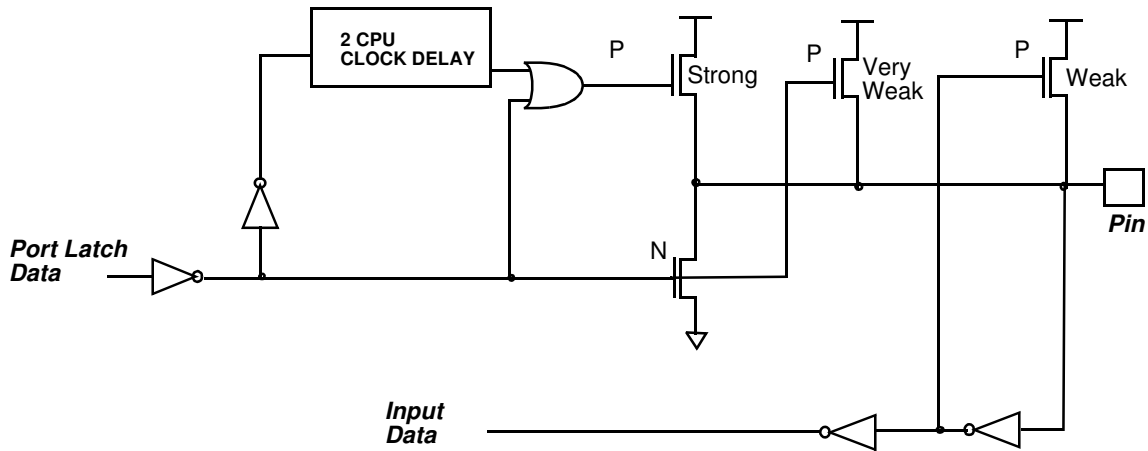

Open-drain Output Configuration

The open-drain output configuration turns off all pull-ups and only drives the pull-down transistor of the port driver when the port latch contains a logic 0. To be used as a logic output, a port configured in this manner must have an external pull-up, typically a resistor tied to V_{DD} . The pull-down for this mode is the same as for the quasi bi-directional mode. The open-drain port configuration is shown in Figure 3.

Figure 2. Open-drain Output

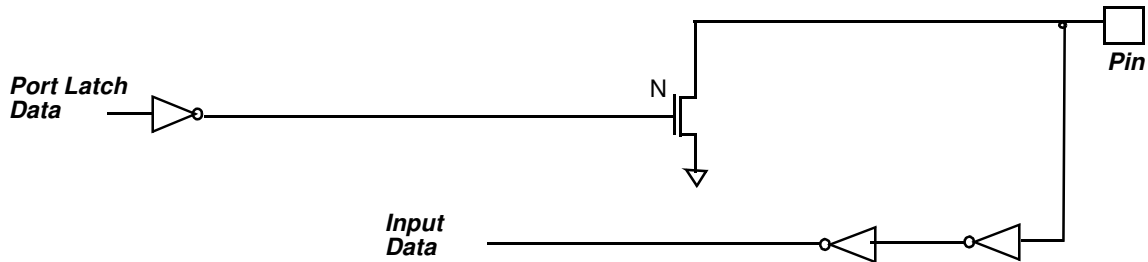

Push-pull Output Configuration

The push-pull output configuration has the same pull-down structure as both the open drain and the quasi bi-directional output modes, but provides a continuous strong pull-up when the port latch contains a logic 1. The push-pull mode may be used when more source current is needed from a port output. The push-pull port configuration is shown in Figure 4.

Figure 3. Push-pull Output

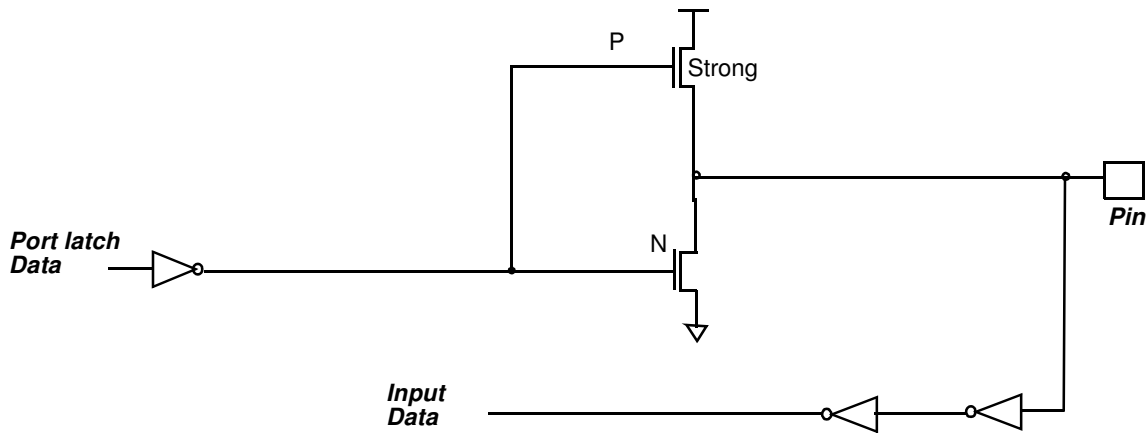

Input Only Configuration

The input only configuration is a pure input with neither pull-up nor pull-down. The input only configuration is shown in Figure 5.

Figure 4. Input only

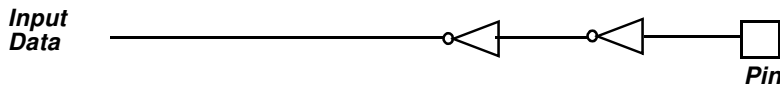

Ports Description

Ports P1, P3 and P4

Every output on the AT8xC5111 may potentially be used as a 20 mA sink LED drive output. However, there is a maximum total output current for all ports which must not be exceeded. All port pins of the AT8xC5111 have slew rate controlled outputs. This is to limit noise generated by quickly switching output signals. The slew rate is factory set to approximately 10 ns rise and fall times.

The inputs of each I/O port of the AT8xC5111 are TTL level Schmitt triggers with hysteresis.

Ports P0 and P2

The high pin-count version of the AT8xC5111 has standard address and data ports P0 and P2. These ports are standard C51 ports (Quasi bi-directional I/O). The control lines are provided on the pins: ALE, PSEN, EA, Reset; RD and WR signals are on the bits P1.1 and P1.0 .

Registers

Table 2. P1M1 Address (D4h)

7	6	5	4	3	2	1	0
P1M1.7	P1M1.6	P1M1.5	P1M1.4	P1M1.3	P1M1.2	P1M1.1	P1M1.0
Bit Number	Bit Mnemonic	Description					
7:0	P1M1.x	Port Output configuration bit See Table 10. for configuration definition					

Reset value = 0000 00XX

Table 3. P1M2 Address (E2h)

7	6	5	4	3	2	1	0
P1M2.7	P1M2.6	P1M2.5	P1M2.4	P1M2.3	P1M2.2	P1M2.1	P1M2.0
Bit Number	Bit Mnemonic	Description					
7:0	P1M2.x	Port Output configuration bit See Table 10. for configuration definition					

Reset value = 0000 00XX

Table 4. P3M1 Address (D5h)

7	6	5	4	3	2	1	0
P3M1.7	P3M1.6	P3M1.5	P3M1.4	P3M1.3	P3M1.2	P3M1.1	P3M1.0
Bit Number	Bit Mnemonic	Description					
7:0	P3M1.x	Port Output configuration bit See Table 10 for configuration definition					

Reset value = 0000 0000

Table 5. P3M2 Address (E4h)

7	6	5	4	3	2	1	0
P3M2.7	P3M2.6	P3M2.5	P3M2.4	P3M2.3	P3M2.2	P3M2.1	P3M2.0
Bit Number	Bit Mnemonic	Description					
7:0	P3M2.x	Port Output configuration bit See Table 10 for configuration definition					

Reset value = 0000 0000

Table 6. P4M1 Address (D6h)

7	6	5	4	3	2	1	0
P4M1.7	P4M1.6	P4M1.5	P4M1.4	P4M1.3	P4M1.2	P4M1.1	P4M1.0
Bit Number	Bit Mnemonic	Description					
7:0	P4M1.x	Port Output configuration bit See Table 10. for configuration definition.					

Reset value = 0000 0000

Table 7. P4M2 Address (E5h)

7	6	5	4	3	2	1	0
P4M2.7	P4M2.6	P4M2.5	P4M2.4	P4M2.3	P4M2.2	P4M2.1	P4M2.0
Bit Number	Bit Mnemonic	Description					
7:0	P4M2.x	Port Output configuration bit See Table 10. for configuration definition.					

Reset value = 0000 0000

Dual Data Pointer Register

The additional data pointer can be used to speed up code execution and reduce code size in a number of ways.

The dual DPTR structure is a way by which the chip will specify the address of an external data memory location. There are two 16-bit DPTR registers that address the external memory, and a single bit called DPS = AUXR1/bit0 (see Table 19) that allows the program code to switch between them (See Figure 6).

Figure 1. Use of Dual Pointer

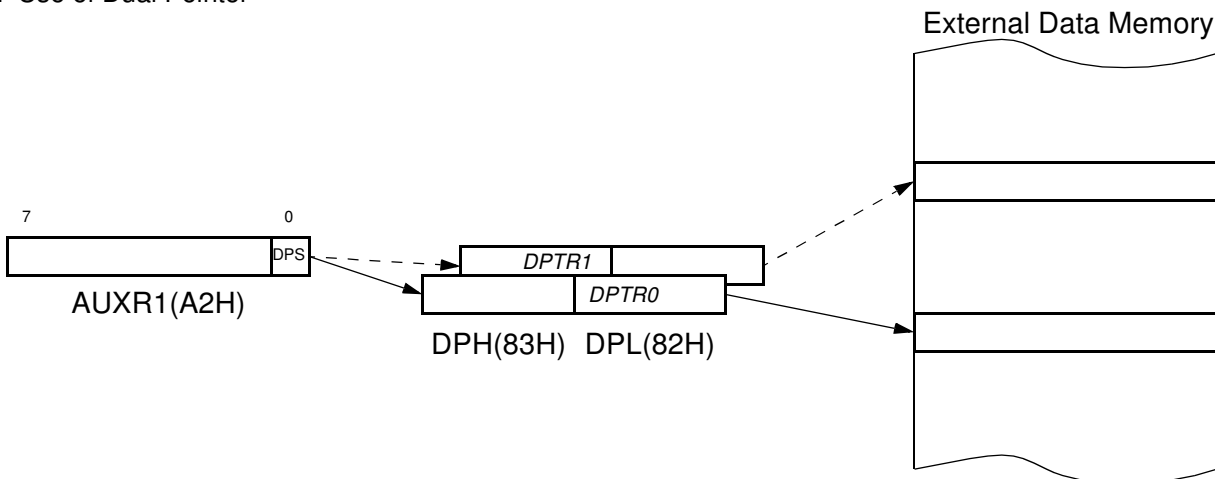

Table 1. AUXR1: Auxiliary Register 1

7	6	5	4	3	2	1	0
-	-	-	-	-	-	-	DPS
Bit Number	Bit Mnemonic	Description					
7	-	Reserved The value read from this bit is indeterminate. Do not set this bit.					
6	-	Reserved The value read from this bit is indeterminate. Do not set this bit.					
5	-	Reserved The value read from this bit is indeterminate. Do not set this bit.					
4	-	Reserved The value read from this bit is indeterminate. Do not set this bit.					
3	-	Reserved The value read from this bit is indeterminate. Do not set this bit.					
2	-	Reserved The value read from this bit is indeterminate. Do not set this bit.					
1	-	Reserved The value read from this bit is indeterminate. Do not set this bit.					
0	DPS	Data Pointer Selection Clear to select DPTR0. Set to select DPTR1.					

Note: User software should not write 1s to reserved bits. These bits may be used in future 8051 family products to invoke new features. In that case, the reset value of the new bit will be 0, and its active value will be 1. The value read from a reserved bit is indeterminate.

Application

Software can take advantage of the additional data pointers to both increase speed and reduce code size, for example, block operations (copy, compare, search...) are well served by using one data pointer as a 'source' pointer and the other one as a "destination" pointer.

ASSEMBLY LANGUAGE

```

; Block move using dual data pointers
; Destroys DPTR0, DPTR1, A and PSW
; note: DPS exits opposite of entry state
; unless an extra INC AUXR1 is added
;
00A2  AUXR1 EQU 0A2H
;
0000 909000MOV DPTR,#SOURCE ; address of SOURCE
0003 05A2 INC AUXR1 ; switch data pointers
0005 90A000 MOV DPTR,#DEST ; address of DEST
0008  LOOP:
0008 05A2 INC AUXR1 ; switch data pointers
000A E0 MOVX A,atDPTR ; get a byte from SOURCE
000B A3 INC DPTR ; increment SOURCE address
000C 05A2 INC AUXR1 ; switch data pointers
000E F0 MOVX atDPTR,A ; write the byte to DEST
000F A3 INC DPTR ; increment DEST address
0010 70F6JNZ LOOP ; check for 0 terminator
0012 05A2 INC AUXR1 ; (optional) restore DPS

```

INC is a short (2 bytes) and fast (12 clocks) way to manipulate the DPS bit in the AUXR1 SFR. However, note that the INC instruction does not directly force the DPS bit to a particular state, but simply toggles it. In simple routines, such as the block move example, only the fact that DPS is toggled in the proper sequence matters, not its actual value. In other words, the block move routine works the same whether DPS is '0' or '1' on entry. Observe that without the last instruction (INC AUXR1), the routine will exit with DPS in the opposite state.

Serial I/O Ports Enhancements

The serial I/O ports in the AT8xC5111 are compatible with the serial I/O port in the 80C52.

They provide both synchronous and asynchronous communication modes. They operate as Universal Asynchronous Receiver and Transmitter (UART) in three full-duplex modes (modes 1, 2 and 3). Asynchronous transmission and reception can occur simultaneously and at different baud rates.

Serial I/O ports include the following enhancements:

- Framing error detection
- Automatic address recognition

Framing Error Detection

Framing bit error detection is provided for the three asynchronous modes (modes 1, 2 and 3). To enable the framing bit error detection feature, set SMOD0 bit in PCON register (see Figure 7).

Figure 1. Framing Error Block Diagram

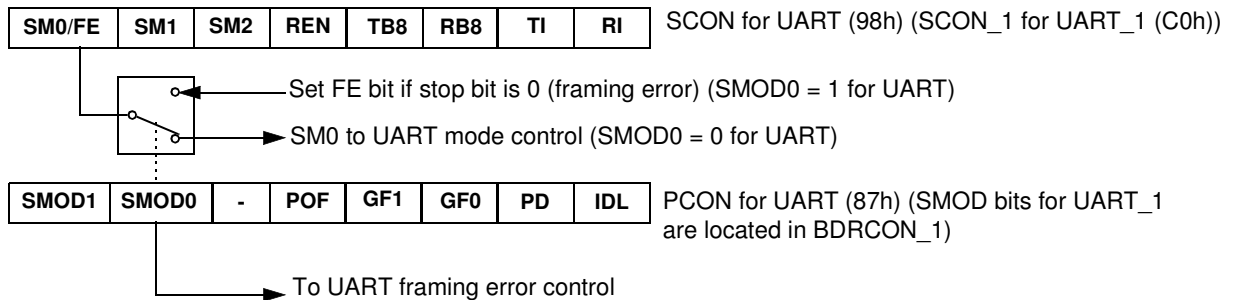

When this feature is enabled, the receiver checks each incoming data frame for a valid stop bit. An invalid stop bit may result from noise on the serial lines or from simultaneous transmission by two CPUs. If a valid stop bit is not found, the Framing Error bit (FE) in SCON register (see Table 25) bit is set.

Software may examine FE bit after each reception to check for data errors. Once set, only software or a reset can clear FE bit. Subsequently received frames with valid stop bits cannot clear FE bit. When FE feature is enabled, RI rises on stop bit instead of the last data bit (see Figure 8 and Figure 9).

Figure 2. UART Timings in Mode 1

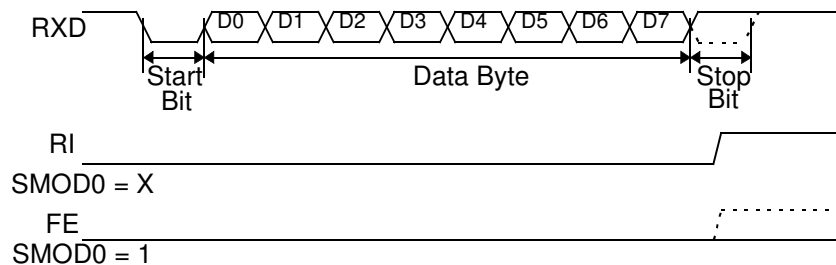
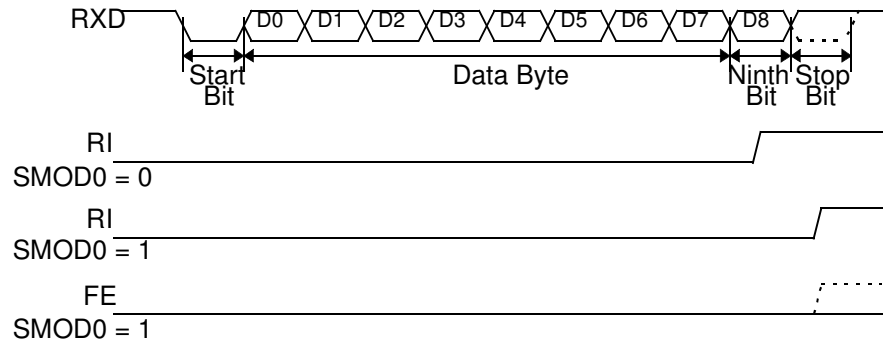

Figure 3. UART Timings in Modes 2 and 3



Automatic Address Recognition

The automatic address recognition feature is enabled for each UART when the multiprocessor communication feature is enabled (SM2 bit in SCON register is set).

Implemented in hardware, automatic address recognition enhances the multiprocessor communication feature by allowing the serial port to examine the address of each incoming command frame. Only when the serial port recognizes its own address, the receiver sets RI bit in SCON register to generate an interrupt. This ensures that the CPU is not interrupted by command frames addressed to other devices.

If desired, you may enable the automatic address recognition feature in mode 1. In this configuration, the stop bit takes the place of the ninth data bit. Bit RI is set only when the received command frame address matches the device's address and is terminated by a valid stop bit.

To support automatic address recognition, a device is identified by a given address and a broadcast address.

Note: The multiprocessor communication and automatic address recognition features cannot be enabled in mode 0 (i.e., setting SM2 bit in SCON register in mode 0 has no effect).

Given Address

Each UART has an individual address that is specified in SADDR register; the SADEN register is a mask byte that contains don't care bits (defined by zeros) to form the device's given address. The don't care bits provide the flexibility to address one or more slaves at a time. The following example illustrates how a given address is formed. To address a device by its individual address, the SADEN mask byte must be 1111 1111b.

For example:

```
SADDR0101 0110b
SADEN1111 1100b
Given0101 01XXb
```

The following is an example of how to use given addresses to address different slaves:

```
Slave A:SADDR1111 0001b
SADEN1111 1010b
Given1111 0X0Xb
```

```
Slave B:SADDR1111 0011b
SADEN1111 1001b
Given1111 0XX1b
```

```
Slave C:SADDR1111 0010b
SADEN1111 1101b
Given1111 00X1b
```

The SADEN byte is selected so that each slave may be addressed separately.

For slave A, bit 0 (the LSB) is a don't care bit; for slaves B and C, bit 0 is a 1. To communicate with slave A only, the master must send an address where bit 0 is clear (e.g. 1111 0000b).

For slave A, bit 1 is a 1; for slaves B and C, bit 1 is a don't care bit. To communicate with slaves B and C, but not slave A, the master must send an address with bits 0 and 1 both set (e.g. 1111 0011b).

To communicate with slaves A, B and C, the master must send an address with bit 0 set, bit 1 clear, and bit 2 clear (e.g. 1111 0001b).

Broadcast Address

A broadcast address is formed from the logical OR of the SADDR and SADEN registers with zeros defined as don't care bits, e.g.:

```
SADDR 0101 0110b
SADEN 1111 1100b
Broadcast = SADDR OR SADEN1111 111Xb
```

The use of don't care bits provides flexibility in defining the broadcast address, however in most applications, a broadcast address is FFh. The following is an example of using broadcast addresses:

```
Slave A: SADDR1111 0001b
         SADEN1111 1010b
         Broadcast1111 1X11b,
```

```
Slave B: SADDR1111 0011b
         SADEN1111 1001b
         Broadcast1111 1X11b,
```

```
Slave C: SADDR = 1111 0010b
         SADEN1111 1101b
         Broadcast1111 1111b
```

For slaves A and B, bit 2 is a don't care bit; for slave C, bit 2 is set. To communicate with all of the slaves, the master must send an address FFh. To communicate with slaves A and B, but not slave C, the master can send an address FBh.

Reset Addresses

On reset, the SADDR and SADEN registers are initialized to 00h, i.e. the given and broadcast addresses are XXXX XXXXb (all don't care bits). This ensures that the serial port will reply to any address, and so, that it is backwards compatible with the 80C51 microcontrollers that do not support automatic address recognition.

Baud Rate Selection for UART for Modes 1 and 3

The Baud Rate Generator for transmit and receive clocks can be selected separately via the T2CON and BDRCON registers.

Figure 4. Baud Rate Selection

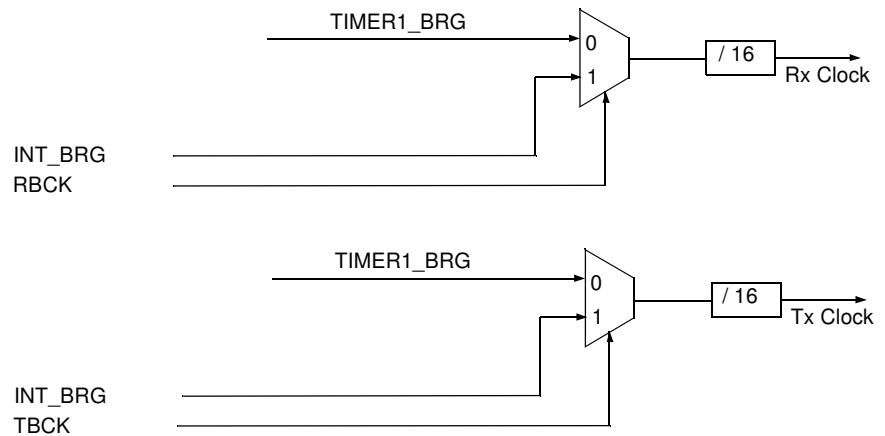

Table 1. Baud Rate Selection Table for UART

TBCK	RBCK	Clock Source for UART Tx	Clock Source UART Rx
0	0	Timer 1	Timer 1
1	0	INT_BRG	Timer 1
0	1	Timer 1	INT_BRG
1	1	INT_BRG	INT_BRG

Internal Baud Rate Generator (BRG)

When the internal Baud Rate Generator is used, the Baud Rates are determined by the BRG overflow depending on the BRL reload value, the X2 bit in CKON0 register, the value of SPD bit (Speed Mode) in BDRCON register and the value of the SMOD1 bit in PCON register (for UART).

Figure 5. Internal Baud Rate Generator

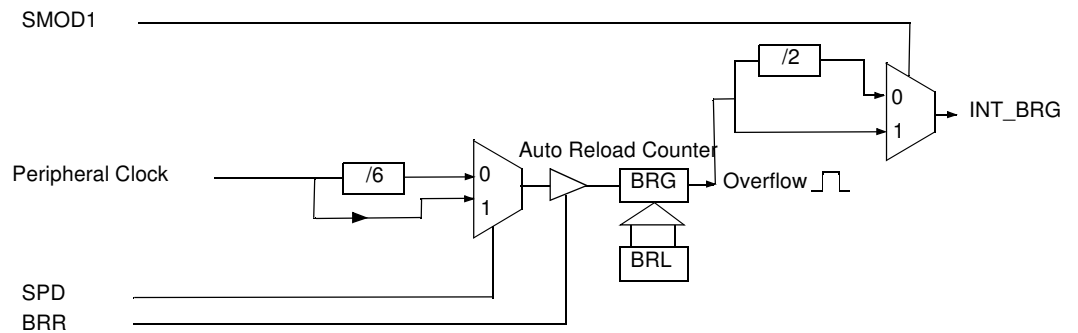

for UART:

$$\text{Baud_Rate} = \frac{2^{\text{SMOD1}} \times 2^{\text{X2}} \times F_{\text{XTAL}}}{2 \times 2 \times 6^{(1-\text{SPD})} \times 16 \times [256 - (\text{BRL})]}$$

$$(\text{BRL}) = 256 - \frac{2^{\text{SMOD1}} \times 2^{\text{X2}} \times F_{\text{XTAL}}}{2 \times 2 \times 6^{(1-\text{SPD})} \times 16 \times \text{Baud_Rate}}$$

Example of computed value when X2 = 1, SMOD1 = 1, SPD = 1

Baud Rates	F _{XTAL} = 16.384 MHz		F _{XTAL} = 24 MHz	
	BRL	Error (%)	BRL	Error (%)
115200	247	1.23	243	0.16
57600	238	1.23	230	0.16
38400	229	1.23	217	0.16
28800	220	1.23	204	0.16
19200	203	0.63	178	0.16
9600	149	0.31	100	0.16
4800	43	1.23	-	-

Example of computed value when X2 = 0, SMOD1 = 0, SPD = 0

Baud Rates	F _{OSC} = 16.384 MHz		F _{OSC} = 24 MHz	
	BRL	Error (%)	BRL	Error (%)
4800	247	1.23	243	0.16
2400	238	1.23	230	0.16
1200	220	1.23	202	3.55
600	185	0.16	152	0.16

The baud rate generator can be used for mode 1 or 3 (See Figure 10), but also for mode 0 for both UARTs, thanks to the bit SRC located in BDRCON register (see Table 27).

UART Registers

Table 2. SADEN - Slave Address Mask Register for UART (B9h)

7	6	5	4	3	2	1	0

Reset value = 0000 0000b

Table 3. SADDR - Slave Address Register for UART (A9h)

7	6	5	4	3	2	1	0

Reset value = 0000 0000b

Table 4. SBUF - Serial Buffer Register for UART (99h)

7	6	5	4	3	2	1	0

Reset value = XXXX XXXXb

Table 5. BRL - Baud Rate Reload Register for the Internal Baud Rate Generator, UART - UART(9Ah)

7	6	5	4	3	2	1	0

Reset value = 0000 0000b

Table 6. SCON Register

SCON - Serial Control Register for UART (98h)

7	6	5	4	3	2	1	0																									
FE/SM0	SM1	SM2	REN	TB8	RB8	TI	RI																									
Bit Number	Bit Mnemonic	Description																														
7	FE	Framing Error bit (SMOD0 = 1) for UART Clear to reset the error state, not cleared by a valid stop bit. Set by hardware when an invalid stop bit is detected. SMOD0 must be set to enable access to the FE bit																														
	SM0	Serial Port Mode bit 0 (SMOD0 = 0) for UART Refer to SM1 for serial port mode selection. SMOD0 must be cleared to enable access to the SM0 bit																														
6	SM1	Serial Port Mode bit 1 for UART <table border="1"> <thead> <tr> <th>SM0</th> <th>SM1</th> <th>Mode</th> <th>Description</th> <th>Baud Rate</th> </tr> </thead> <tbody> <tr> <td>0</td> <td>0</td> <td>0</td> <td>Shift Register</td> <td>$F_{XTAL}/12$ ($F_{XTAL}/6$ X2 mode)</td> </tr> <tr> <td>0</td> <td>1</td> <td>1</td> <td>8-bit UART</td> <td>Variable</td> </tr> <tr> <td>1</td> <td>0</td> <td>2</td> <td>9-bit UART</td> <td>$F_{XTAL}/64$ or $F_{XTAL}/32$ ($F_{XTAL}/32$ or $F_{XTAL}/16$ X2 mode)</td> </tr> <tr> <td>1</td> <td>1</td> <td>3</td> <td>9-bit UART</td> <td>Variable</td> </tr> </tbody> </table>						SM0	SM1	Mode	Description	Baud Rate	0	0	0	Shift Register	$F_{XTAL}/12$ ($F_{XTAL}/6$ X2 mode)	0	1	1	8-bit UART	Variable	1	0	2	9-bit UART	$F_{XTAL}/64$ or $F_{XTAL}/32$ ($F_{XTAL}/32$ or $F_{XTAL}/16$ X2 mode)	1	1	3	9-bit UART	Variable
SM0	SM1	Mode	Description	Baud Rate																												
0	0	0	Shift Register	$F_{XTAL}/12$ ($F_{XTAL}/6$ X2 mode)																												
0	1	1	8-bit UART	Variable																												
1	0	2	9-bit UART	$F_{XTAL}/64$ or $F_{XTAL}/32$ ($F_{XTAL}/32$ or $F_{XTAL}/16$ X2 mode)																												
1	1	3	9-bit UART	Variable																												
5	SM2	Serial Port Mode 2 bit/Multiprocessor Communication Enable bit for UART Clear to disable multiprocessor communication feature. Set to enable multiprocessor communication feature in mode 2 and 3, and eventually mode 1. This bit should be cleared in mode 0.																														
4	REN	Reception Enable bit for UART Clear to disable serial reception. Set to enable serial reception.																														
3	TB8	Transmitter Bit 8/Ninth bit to transmit in modes 2 and 3 for UART. Clear to transmit a logic 0 in the 9th bit. Set to transmit a logic 1 in the 9th bit.																														
2	RB8	Receiver Bit 8/Ninth bit received in modes 2 and 3 for UART Cleared by hardware if 9th bit received is a logic 0. Set by hardware if 9th bit received is a logic 1. In mode 1, if SM2 = 0, RB8 is the received stop bit. In mode 0 RB8 is not used.																														
1	TI	Transmit Interrupt flag for UART Clear to acknowledge interrupt. Set by hardware at the end of the 8th bit time in mode 0 or at the beginning of the stop bit in the other modes.																														
0	RI	Receive Interrupt flag for UART Clear to acknowledge interrupt. Set by hardware at the end of the 8th bit time in mode 0, see Figure 8 and Figure 9 in the other modes.																														

Reset value = 0000 0000b

Bit addressable

Table 7. PCON Register
PCON - Power Control Register (87h)

7	6	5	4	3	2	1	0
SMOD1	SMOD0	RSTD	POF	GF1	GF0	PD	IDL
Bit Number	Bit Mnemonic	Description					
7	SMOD1	Serial Port Mode bit 1 for UART Set to select double baud rate in mode 1, 2 or 3.					
6	SMOD0	Serial Port Mode bit 0 for UART Clear to select SM0 bit in SCON register. Set to to select FE bit in SCON register.					
5	RSTD	Reset Detector Disable Bit Clear to disable PFD. Set to enable PFD.					
4	POF	Power-off Flag Clear to recognize next reset type. Set by hardware when VCC rises from 0 to its nominal voltage. Can also be set by software.					
3	GF1	General-purpose Flag Cleared by user for general purpose usage. Set by user for general purpose usage.					
2	GF0	General-purpose Flag Cleared by user for general purpose usage. Set by user for general purpose usage.					
1	PD	Power-down Mode bit Cleared by hardware when reset occurs. Set to enter Power-down mode.					
0	IDL	Idle Mode bit Clear by hardware when interrupt or reset occurs. Set to enter idle mode.					

Reset value = 0001 0000b

Not bit addressable

Power-off flag reset value will be 1 only after a power on (cold reset). A warm reset doesn't affect the value of this bit.

Table 8. BDRCON Register
BDRCON - Baud Rate Control Register (9Bh)

7	6	5	4	3	2	1	0
-	-	-	BRR	TBCK	RBCK	SPD	SRC
Bit Number	Bit Mnemonic	Description					
7	-	Reserved The value read from this bit is indeterminate. Do not set this bit.					
6	-	Reserved The value read from this bit is indeterminate. Do not set this bit.					
5	-	Reserved The value read from this bit is indeterminate. Do not set this bit.					
4	BRR	Baud Rate Run Control bit Clear to stop the internal Baud Rate Generator. Set to start the internal Baud Rate Generator.					
3	TBCK	Transmission Baud rate Generator Selection bit for UART Clear to select Timer 1 or Timer 2 for the Baud Rate Generator. Set to select internal Baud Rate Generator.					
2	RBCK	Reception Baud Rate Generator Selection bit for UART Clear to select Timer 1 or Timer 2 for the Baud Rate Generator. Set to select internal Baud Rate Generator.					
1	SPD	Baud Rate Speed Control bit for UART Clear to select the SLOW Baud Rate Generator. Set to select the FAST Baud Rate Generator.					
0	SRC	Baud Rate Source Select bit in Mode 0 for UART Clear to select $F_{OSC}/12$ as the Baud Rate Generator ($F_{OSC}/6$ in X2 mode). Set to select the internal Baud Rate Generator for UARTs in mode 0.					

Reset value = XXX0 0000b

Serial Port Interface (SPI)

The Serial Peripheral Interface (SPI) module which allows full-duplex, synchronous, serial communication between the MCU and peripheral devices, including other MCUs.

Features

Features of the SPI module include the following:

- Full-duplex, three-wire synchronous transfers
- Master operation
- Eight programmable Master clock rates
- Serial clock with programmable polarity and phase
- Master Mode fault error flag with MCU interrupt capability
- Write collision flag protection

Signal Description

Figure 12 shows a typical SPI bus configuration using one Master controller and many Slave peripherals. The bus is made of three wires connecting all the devices:

Figure 1. Typical SPI bus

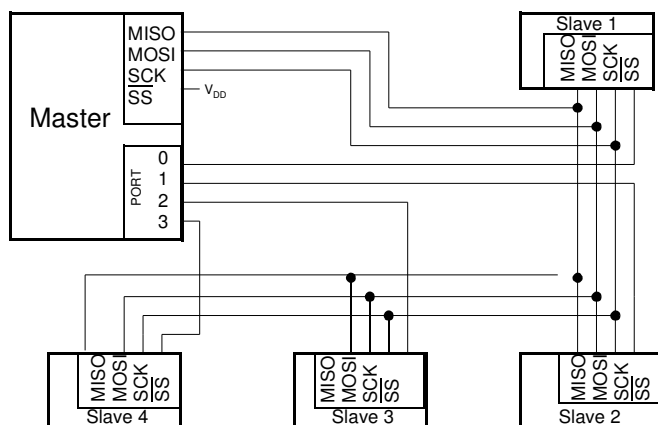

The Master device selects the individual Slave devices by using four pins of a parallel port to control the four \overline{SS} pins of the Slave devices.

Master Output Slave Input (MOSI)

This 1-bit signal is directly connected between the Master Device and a Slave Device. The MOSI line is used to transfer data in series from the Master to the Slave. Therefore, it is an output signal from the Master, and an input signal to a Slave. A byte (8-bit word) is transmitted most significant bit (MSB) first, least significant bit (LSB) last.

Master Input Slave Output (MISO)

This 1-bit signal is directly connected between the Slave Device and a Master Device. The MISO line is used to transfer data in series from the Slave to the Master. Therefore, it is an output signal from the Slave, and an input signal to the Master. A byte (8-bit word) is transmitted most significant bit (MSB) first, least significant bit (LSB) last.

SPI Serial Clock (SCK)

This signal is used to synchronize the data movement both in and out the devices through their MOSI and MISO lines. It is driven by the Master for eight clock cycles which allows to exchange one byte on the serial lines.

Slave Select (\overline{SS})

Each Slave peripheral is selected by one Slave Select pin (\overline{SS}). This signal must stay low for any message for a Slave. It is obvious that only one Master (\overline{SS} high level) can drive the network. The Master may select each Slave device by software through port

pins (see Figure 12). To prevent bus conflicts on the MISO line, only one slave should be selected at a time by the Master for a transmission.

In a Master configuration, the \overline{SS} line can be used in conjunction with the MODF flag in the SPI Status register (SPSTA) to prevent multiple masters from driving MOSI and SCK (see Error Conditions).

Baud Rate

In Master mode, the baud rate can be selected from a baud rate generator which is controlled by three bits in the SPCON register: SPR2, SPR1 and SPR0. The Master clock is chosen from one of seven clock rates resulting from the division of the internal clock by 2, 4, 8, 16, 32, 64 or 128, or an external clock.

Table 28 gives the different clock rates selected by SPR2:SPR1:SPR0.

Table 1. SPI Master Baud Rate Selection

SPR2:SPR1:SPR0	Clock Rate	Baud Rate Divisor (BD)
000	$F_{CkIdle} / 2$	2
001	$F_{CkIdle} / 4$	4
010	$F_{CkIdle} / 8$	8
011	$F_{CkIdle} / 16$	16
100	$F_{CkIdle} / 32$	32
101	$F_{CkIdleH} / 64$	64
110	$F_{CkIdle} / 128$	128
111	External clock	Output of BRG

Functional Description Figure 13 shows a detailed structure of the SPI module.

Figure 2. SPI Module Block Diagram

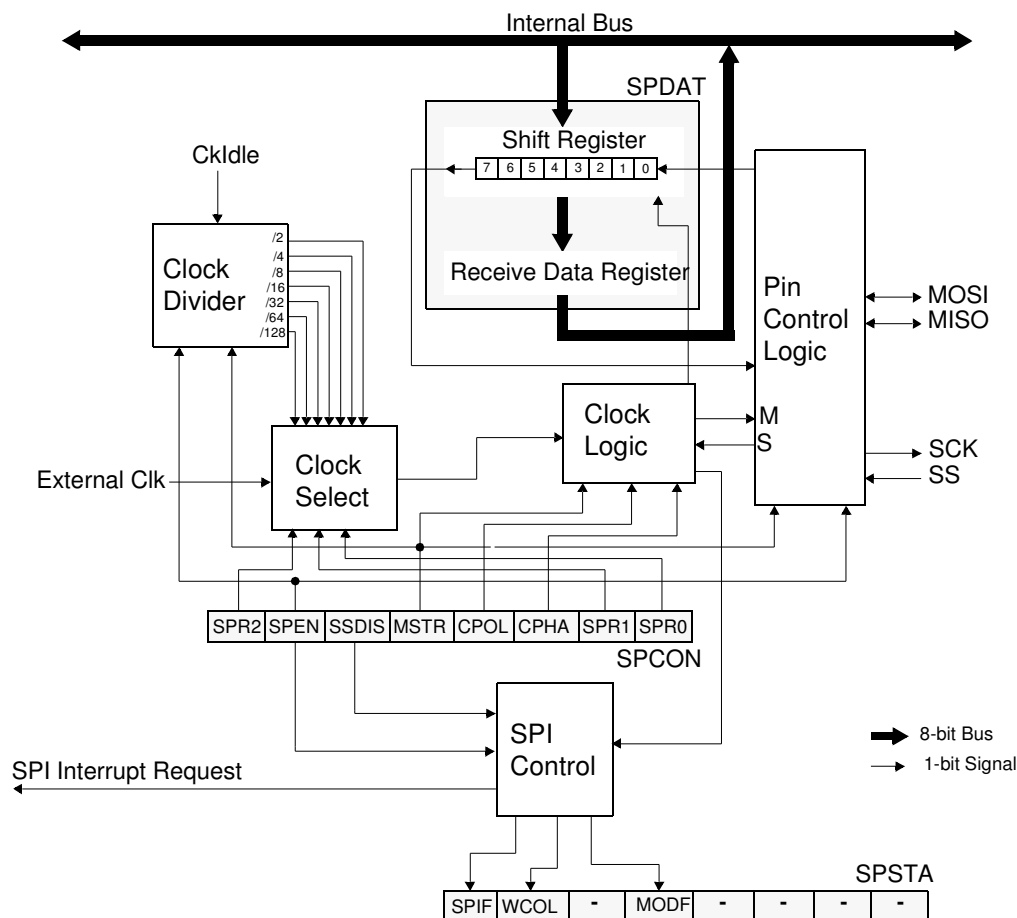

Operating Modes

The Serial Peripheral Interface can be configured as Master mode only. The configuration and initialization of the SPI module is made through one register:

- The Serial Peripheral CONTROL register (SPCON)

Once the SPI is configured, the data exchange is made using:

- SPCON
- The Serial Peripheral STATUS register (SPSTA)
- The Serial Peripheral DATA register (SPDAT)

During an SPI transmission, data is simultaneously transmitted (shifted out serially) and received (shifted in serially). A serial clock line (SCK) synchronizes shifting and sampling on the two serial data lines (MOSI and MISO).

When the Master device transmits data to the Slave device via the MOSI line, the Slave device responds by sending data to the Master device via the MISO line. This implies full-duplex transmission with both data out and data in synchronized with the same clock (Figure 14).

Figure 3. Full-Duplex Master-slave Interconnection

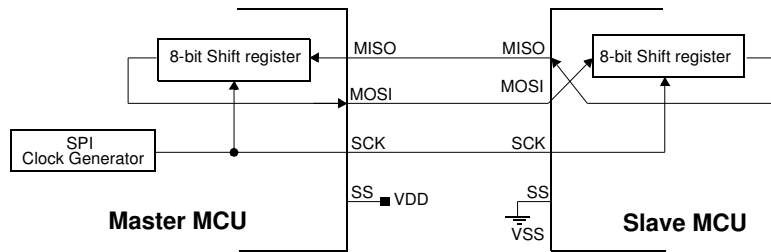

Master Mode

The SPI operates in Master mode. Only one Master SPI device can initiate transmissions. Software begins the transmission from a Master SPI module by writing to the Serial Peripheral Data Register (SPDAT). If the shift register is empty, the byte is immediately transferred to the shift register. The byte begins shifting out on MOSI pin under the control of the serial clock, SCK. Simultaneously, another byte shifts in from the Slave on the Master's MISO pin. The transmission ends when the Serial Peripheral transfer data flag, SPIF, in SPSTA becomes set. At the same time that SPIF becomes set, the received byte from the Slave is transferred to the receive data register in SPDAT. Software clears SPIF by reading the Serial Peripheral Status register (SPSTA) with the SPIF bit set, and then reading the SPDAT.

When the pin SS is pulled down during a transmission, the data is interrupted and when the transmission is established again, the data present in the SPDAT is present.

Transmission Formats

Software can select any of four combinations of serial clock (SCK) phase and polarity using two bits in the SPCON: the Clock POLarity (CPOL⁽¹⁾) and the Clock PHase (CPHA⁽¹⁾). CPOL defines the default SCK line level in idle state. It has no significant effect on the transmission format. CPHA defines the edges on which the input data are sampled and the edges on which the output data are shifted (Figure 15 and Figure 16). The clock phase and polarity should be identical for the Master SPI device and the communicating Slave device.

Figure 4. Data Transmission Format (CPHA = 0)

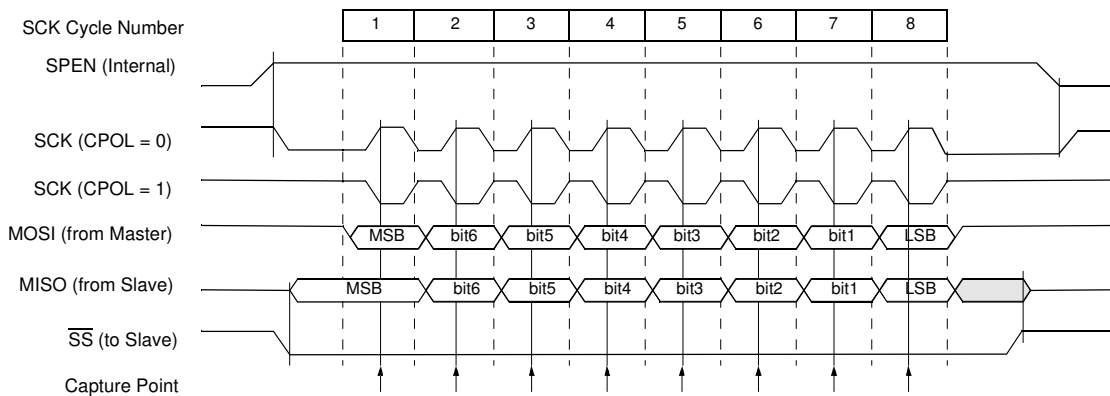

1. Before writing to the CPOL and CPHA bits, the SPI should be disabled (SPEN = '0').

Figure 16 shows an SPI transmission in which CPHA is '1'. In this case, the Master begins driving its MOSI pin on the first SCK edge. Therefore the Slave uses the first SCK edge as a start transmission signal. The SS pin can remain low between transmissions (Figure 17). This format may be preferable in systems having only one Master and only one Slave driving the MISO data line.

Figure 5. Data Transmission Format (CPHA = 1)

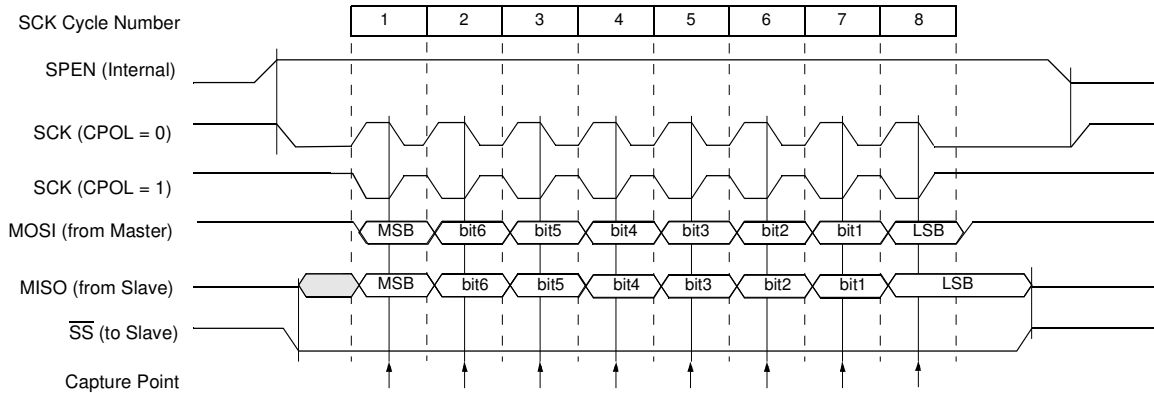
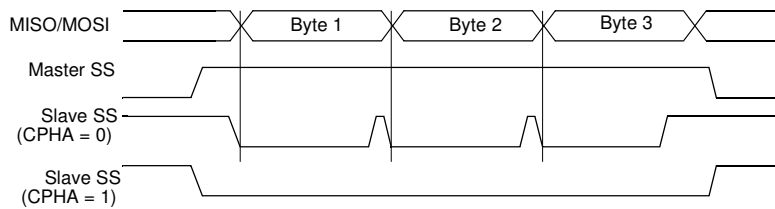

Figure 15 shows the first SCK edge is the MSB capture strobe. Therefore, the Slave must begin driving its data before the first SCK edge, and a falling edge on the SS pin is used to start the transmission. The SS pin must be toggled high and then low between each byte transmitted (Figure 17).

Figure 6. CPHA/SS Timing



Error Conditions

Mode Fault (MODF)

The following flags in the SPSTA signal SPI error conditions:

Mode Fault error in Master mode SPI indicates that the level on the Slave Select (\overline{SS}) pin is inconsistent with the actual mode of the device. MODF is set to warn that there may be a multi-master conflict for system control. In this case, the SPI system is affected in the following ways:

- An SPI receiver/error CPU interrupt request is generated.
- The SPEN bit in SPCON is cleared. This disables the SPI.
- The MSTR bit in SPCON is cleared.

The MODF flag is set when the \overline{SS} signal becomes '0'.

However, as stated before, for a system with one Master, if the \overline{SS} pin of the Master device is pulled low, there is no way that another Master is attempting to drive the network. In this case, clearing the MODF bit is accomplished by a read of SPSTA register with MODF bit set, followed by a write to the SPCON register. SPEN Control bit may be restored to its original set state after the MODF bit has been cleared.

Write Collision (WCOL)

A Write Collision (WCOL) flag in the SPSTA is set when a write to the SPDAT register is done during a transmit sequence.

WCOL does not cause an interruption, and the transfer continues uninterrupted.

Clearing the WCOL bit is done through a software sequence of an access to SPSTA and an access to SPDAT.

Overrun Condition

An overrun condition occurs when the Master device tries to send several data bytes and the Slave device has not cleared the SPIF bit issuing from the previous data byte transmitted. In this case, the receiver buffer contains the byte sent after the SPIF bit was last cleared. A read of the SPDAT returns this byte. All others bytes are lost.

This condition is not detected by the SPI peripheral.

Interrupts

Two SPI status flags can generate a CPU interrupt request:

Table 2. SPI Interrupts

Flag	Request
SPIF (SP data transfer)	SPI Transmitter Interrupt request
MODF (Mode Fault)	SPI Receiver/Error Interrupt Request (if SSDIS = '0')

Serial Peripheral data transfer flag, SPIF: This bit is set by hardware when a transfer has been completed. SPIF bit generates transmitter CPU interrupt requests.

Mode Fault flag, MODF: This bit becomes set to indicate that the level on the \overline{SS} is inconsistent with the mode of the SPI. MODF generates receiver/error CPU interrupt requests.

Figure 18 gives a logical view of the above statements.

Figure 7. SPI Interrupt Requests Generation

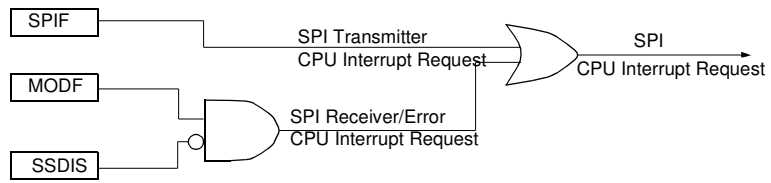

Registers

Serial Peripheral Control Register (SPCON)

There are three registers in the module that provide control, status and data storage functions. These registers are described in the following paragraphs.

The Serial Peripheral Control Register does the following:

- Selects one of the Master clock rates
- Selects serial clock polarity and phase
- Enables the SPI module

Table 30 describes this register and explains the use of each bit:

Table 3. Serial Peripheral Control Register

7	6	5	4	3	2	1	0
SPR2	SPEN	–	–	CPOL	CPHA	SPR1	SPR0
Bit Number	Bit Mnemonic	R/W Mode	Description				
7	SPR2	RW	Serial Peripheral Rate 2 Bit with SPR1 and SPR0 define the clock rate				
6	SPEN	RW	Serial Peripheral Enable Clear to disable the SPI interface Set to enable the SPI interface				
5	-	RW	Reserved Leave this Bit at 0.				
4	-	RW	Reserved Leave this Bit at 1.				
3	CPOL	RW	Clock Polarity Clear to have the SCK set to '0' in idle state Set to have the SCK set to '1' in idle low				
2	CPHA	RW	Clock Phase Clear to have the data sampled when the SPSCCK leaves the idle state (see CPOL) Set to have the data sampled when the SPSCCK returns to idle state (see CPOL)				
1	SPR1	RW	Serial Peripheral Rate (SPR2:SPR1:SPR0) 000: $F_{CkIdle} / 2$ 001: $F_{CkIdle} / 4$ 010: $F_{CkIdle} / 8$ 011: $F_{CkIdle} / 16$				
0	SPR0	RW	100: $F_{CkIdle} / 32$ 101: $F_{CkIdle} / 64$ 110: $F_{CkIdle} / 128$ 111: External clock, output of BRG				

Reset value = 00010100b

Serial Peripheral Status Register (SPSTA) The Serial Peripheral Status Register contains flags to signal the following conditions.

- Data transfer complete
- Write collision
- Inconsistent logic level on \overline{SS} pin (mode fault error)

Table 31 describes the SPSTA register and explains the use of every bit in the register:

Table 4. Serial Peripheral Status and Control Register

7	6	5	4	3	2	1	0
SPIF	WCOL	-	MODF	-	-	-	-
Bit Number	Bit Mnemonic	R/W Mode	Description				
7	SPIF	R	Serial Peripheral data transfer flag Cleared by hardware to indicate data that transfer is in progress or has been approved by a clearing sequence. Set by hardware to indicate that the data transfer has been completed.				
6	WCOL	R	Write Collision flag Cleared by hardware to indicate that no collision has occurred or has been approved by a clearing sequence. Set by hardware to indicate that a collision has been detected.				
5	-	RW	Reserved The value read from this bit is indeterminate. Do not set this bit				
4	MODF	R	Mode Fault Cleared by hardware to indicate that the \overline{SS} pin is at appropriate logic level, or has been approved by a clearing sequence. Set by hardware to indicate that the \overline{SS} pin is at inappropriate logic level				
3	-	RW	Reserved The value read from this bit is indeterminate. Do not set this bit				
2	-	RW	Reserved The value read from this bit is indeterminate. Do not set this bit				
1	-	RW	Reserved The value read from this bit is indeterminate. Do not set this bit				
0	-	RW	Reserved The value read from this bit is indeterminate. Do not set this bit				

Reset value = 00X0XXXXb

Serial Peripheral Data Register (SPDAT)

The Serial Peripheral Data Register (Table 32) is a read/write buffer for the receive data register. A write to SPDAT places data directly into the shift register. No transmit buffer is available in this model.

A Read of the SPDAT returns the value located in the receive buffer and not the content of the shift register.

Table 5. Serial Peripheral Data Register

7	6	5	4	3	2	1	0
R7	R6	R5	R4	R3	R2	R1	R0

Reset value = XXXX XXXXb

R7:R0: Receive data bits

SPCON, SPSTA and SPDAT registers may be read and written at any time while there is no on-going exchange. However, special care should be taken when writing to them while a transmission is on-going:

- Do not change SPR2, SPR1 and SPR0
- Do not change CPHA and CPOL
- Do not change MSTR
- Clearing SPEN would immediately disable the peripheral
- Writing to the SPDAT will cause an overflow

Programmable Counter Array (PCA)

The PCA provides more timing capabilities with less CPU intervention than the standard timer/counters. Its advantages include reduced software overhead and improved accuracy. The PCA consists of a dedicated timer/counter which serves as the time base for an array of five compare/capture modules. Its clock input can be programmed to count any one of the following signals:

- Oscillator frequency $\div 12$ ($\div 6$ in X2 mode)
- Oscillator frequency $\div 4$ ($\div 2$ in X2 mode)
- Timer 0 overflow
- External input on ECI (P1.2)

Each compare/capture modules can be programmed in any one of the following modes:

- rising and/or falling edge capture
- software timer
- high-speed output
- pulse width modulator

Module 4 can also be programmed as a watchdog timer (see Section "PCA PWM Mode", page 53).

When the compare/capture modules are programmed in the capture mode, software timer, or high-speed output mode, an interrupt can be generated when the module executes its function. All five modules plus the PCA timer overflow share one interrupt vector.

The PCA timer/counter and compare/capture modules share Port 1 for external I/O. These pins are listed below. If the port is not used for the PCA, it can still be used for standard I/O.

PCA Component	External I/O Pin
16-bit Counter	P1.2/ECI
16-bit Module 0	P1.3/CEX0
16-bit Module 1	P1.4/CEX1
16-bit Module 2	P1.5/CEX2
16-bit Module 3	P1.6/CEX3
16-bit Module 4	P1.7/CEX4

The PCA timer is a common time base for all five modules (see Figure 19). The timer count source is determined from the CPS1 and CPS0 bits in the **CMOD SFR** (see Table 33) and can be programmed to run at:

- 1/12 the oscillator frequency. (Or 1/6 in X2 Mode).
- 1/4 the oscillator frequency. (Or 1/2 in X2 Mode).
- The Timer 0 overflow.
- The input on the ECI pin (P1.2).

Figure 1. PCA Timer/Counter

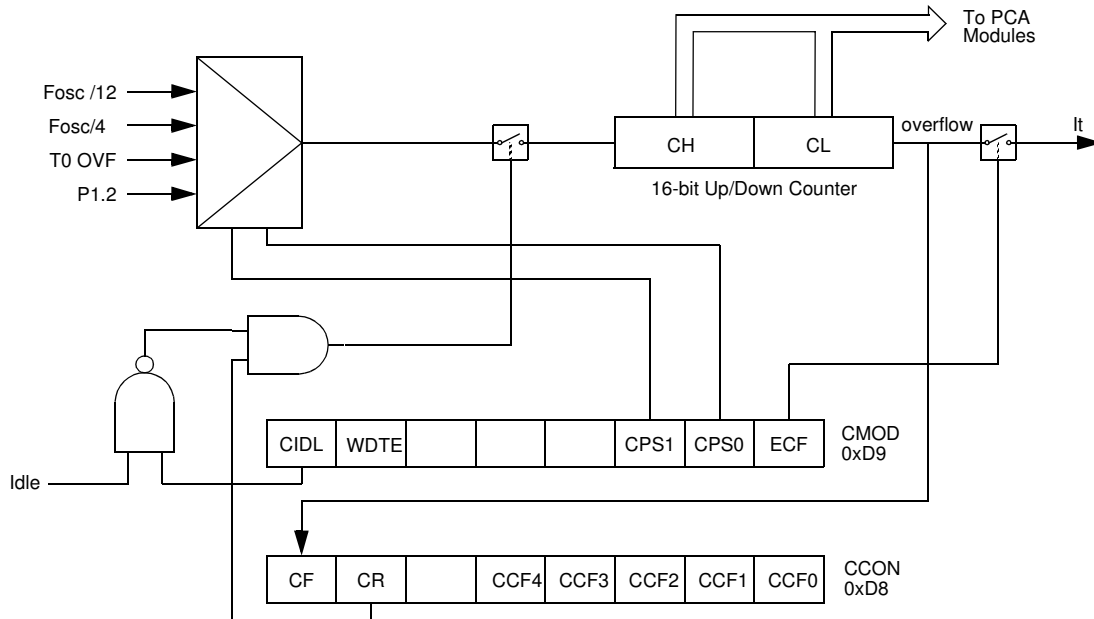

Table 1. CMOD: PCA Counter Mode Register - CMOD Address 0D9H

7	6	5	4	3	2	1	0
CIDL	WDTE	-	-	-	CPS1	CPS0	ECF
Bit Number	Bit Mnemonic	Description					
7	CIDL	Counter Idle control: CIDL = 0 programs the PCA Counter to continue functioning during idle Mode. CIDL = 1 programs it to be gated off during idle.					
6	WDTE	Watchdog Timer Enable: WDTE = 0 disables Watchdog Timer function on PCA Module 4. WDTE = 1 enables it.					
5	-	Not implemented, reserved for future use. ⁽¹⁾					
4	-	Not implemented, reserved for future use.					
3	-	Not implemented, reserved for future use.					
2	CPS1	CPS1	CPS0	Selected PCA input ⁽²⁾			
		0	0	Internal clock $f_{osc}/12$ (Or $f_{osc}/6$ in X2 Mode).			
		0	1	Internal clock $f_{osc}/4$ (Or $f_{osc}/2$ in X2 Mode).			
		1	0	Timer 0 Overflow			
1	CPS0	PCA Count Pulse Select bit 0.					
0	ECF	PCA Enable Counter Overflow interrupt: ECF = 1 enables CF bit in CCON to generate an interrupt. ECF = 0 disables that function of CF.					

Reset value = 00XXX00

1. User software should not write 1s to reserved bits. These bits may be used in future 8051 family products to invoke new features. In that case, the reset or inactive value of the new bit will be 0, and its active value will be 1. The value read from a reserved bit is indeterminate.
2. f_{osc} = oscillator frequency

The CMOD SFR includes three additional bits associated with the PCA (See Figure 19 and Table 33).

- The CIDL bit which allows the PCA to stop during idle mode.
- The WDTE bit which enables or disables the watchdog function on module 4.
- The ECF bit which when set causes an interrupt and the PCA overflow flag CF (in the CCON SFR) to be set when the PCA timer overflows.

The CCON SFR contains the run control bit for the PCA and the flags for the PCA timer (CF) and each module (see Table 34).

- Bit CR (CCON.6) must be set by software to run the PCA. The PCA is shut off by clearing this bit.
- Bit CF: The CF bit (CCON.7) is set when the PCA counter overflows and an interrupt will be generated if the ECF bit in the CMOD register is set. The CF bit can only be cleared by software.
- Bits 0 through 4 are the flags for the modules (bit 0 for module 0, bit 1 for module 1, etc.) and are set by hardware when either a match or a capture occurs. These flags also can only be cleared by software.

Table 2. CCON: PCA Counter Control Register
CCON Address OD8H

7	6	5	4	3	2	1	0
CF	CR	-	CCF4	CCF3	CCF2	CCF1	CCF0

Bit Number	Bit Mnemonic	Description
7	CF	PCA Counter Overflow flag. Set by hardware when the counter rolls over. CF flags an interrupt if bit ECF in CMOD is set. CF may be set by either hardware or software but can only be cleared by software.
6	CR	PCA Counter Run control bit. Set by software to turn the PCA counter on. Must be cleared by software to turn the PCA counter off.
5	-	Not implemented, reserved for future use ⁽¹⁾ .
4	CCF4	PCA Module 4 interrupt flag. Set by hardware when a match or capture occurs. Must be cleared by software.
3	CCF3	PCA Module 3 interrupt flag. Set by hardware when a match or capture occurs. Must be cleared by software.
2	CCF2	PCA Module 2 interrupt flag. Set by hardware when a match or capture occurs. Must be cleared by software.
1	CCF1	PCA Module 1 interrupt flag. Set by hardware when a match or capture occurs. Must be cleared by software.
0	CCF0	PCA Module 0 interrupt flag. Set by hardware when a match or capture occurs. Must be cleared by software.

1. User software should not write 1s to reserved bits. These bits may be used in future 8051 family products to invoke new features. In that case, the reset or inactive value of the new bit will be 0, and its active value will be 1. The value read from a reserved bit is indeterminate.

The watchdog timer function is implemented in module 4 (see Figure 22).

The PCA interrupt system is shown in Figure 20 below.

Figure 2. PCA Interrupt System

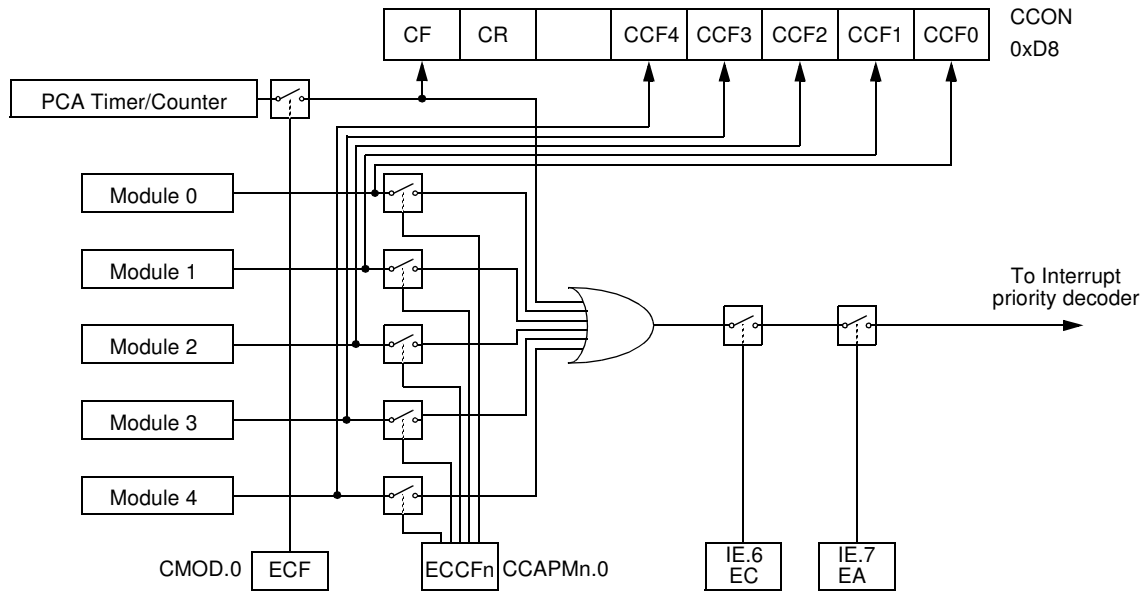

PCA Modules: each one of the five compare/capture modules has six possible functions. It can perform:

- 16-bit Capture, positive-edge triggered
- 16-bit Capture, negative-edge triggered
- 16-bit Capture, both positive and negative-edge triggered
- 16-bit Software Timer
- 16-bit High-speed Output
- 8-bit Pulse Width Modulator

In addition, module 4 can be used as a Watchdog Timer.

Each module in the PCA has a special function register associated with it. These registers are: CCAPM0 for module 0, CCAPM1 for module 1, etc. (see Table 35). The registers contain the bits that control the mode that each module will operate in.

- The ECCF bit (CCAPMn.0 where n = 0, 1, 2, 3, or 4 depending on the module) enables the CCF flag in the CCON SFR to generate an interrupt when a match or compare occurs in the associated module.
- PWM (CCAPMn.1) enables the pulse width modulation mode.
- The TOG bit (CCAPMn.2) when set causes the CEX output associated with the module to toggle when there is a match between the PCA counter and the module's capture/compare register.
- The match bit MAT (CCAPMn.3) when set will cause the CCFn bit in the CCON register to be set when there is a match between the PCA counter and the module's capture/compare register.
- The next two bits CAPN (CCAPMn.4) and CAPP (CCAPMn.5) determine the edge that a capture input will be active on. The CAPN bit enables the negative edge, and the CAPP bit enables the positive edge. If both bits are set both edges will be enabled and a capture will occur for either transition.

- The last bit in the register ECOM (CCAPMn.6) when set enables the comparator function.

Table 35 shows the CCAPMn settings for the various PCA functions.

Table 3. CCAPMn: PCA Modules Compare/Capture Control Registers
CAPMn Address n = 0 - 4

7	6	5	4	3	2	1	0
-	ECOMn	CAPPn	CAPn	MATn	TOGn	PWMm	ECCFn

Bit Number	Bit Mnemonic	Description
7	-	Not implemented, reserved for future use. ⁽¹⁾
6	ECOMn	Enable Comparator. ECOMn = 1 enables the comparator function.
5	CAPPn	Capture Positive, CAPPn = 1 enables positive edge capture.
4	CAPNn	Capture Negative, CAPNn = 1 enables negative edge capture.
3	MATn	Match. When MATn = 1, a match of the PCA counter with this module's compare/capture register causes the CCFn bit in CCON to be set, flagging an interrupt.
2	TOGn	Toggle. When TOGn = 1, a match of the PCA counter with this module's compare/capture register causes the CEXn pin to toggle.
1	PWMn	Pulse Width Modulation Mode. PWMn = 1 enables the CEXn pin to be used as a pulse width modulated output.
0	ECCFn	Enable CCF interrupt. Enables compare/capture flag CCFn in the CCON register to generate an interrupt.

Reset value = X000000

- User software should not write 1s to reserved bits. These bits may be used in future 8051 family products to invoke new features. In that case, the reset or inactive value of the new bit will be 0, and its active value will be 1. The value read from a reserved bit is indeterminate.

Table 4. PCA Module Modes (CCAPMn Registers)

ECOMn	CAPPn	CAPNn	MATn	TOGn	PWMm	ECCFn	Module Function
0	0	0	0	0	0	0	No Operation
X	1	0	0	0	0	X	16-bit capture by a positive-edge trigger on CEXn
X	0	1	0	0	0	X	16-bit capture by a negative trigger on CEXn
X	1	1	0	0	0	X	16-bit capture by a transition on CEXn
1	0	0	1	0	0	X	16-bit Software Timer/Compare mode.
1	0	0	1	1	0	X	16-bit High-speed Output
1	0	0	0	0	1	0	8-bit PWM
1	0	0	1	X	0	X	Watchdog Timer (module 4 only)

There are two additional registers associated with each of the PCA modules. They are CCAPnH and CCAPnL and these are the registers that store the 16-bit count when a capture occurs or a compare should occur. When a module is used in the PWM mode these registers are used to control the duty cycle of the output (See Table 37 & Table 38)

Table 5. CCAPnH: PCA Modules Capture/Compare Registers High

CCAPnH Address n = 0 - 4	CCAP0H = 0FAH	7	6	5	4	3	2	1	0
	CCAP1H = 0FBH	0	0	0	0	0	0	0	0
	CCAP2H = 0FCH								
	CCAP3H = 0FDH								
	CCAP4H = 0FEH								
Reset value		0	0	0	0	0	0	0	0

Table 6. CCAPnL: PCA Modules Capture/Compare Registers Low

CCAPnL Address n = 0 - 4	CCAP0L = 0EAH	7	6	5	4	3	2	1	0
	CCAP1L = 0EBH	0	0	0	0	0	0	0	0
	CCAP2L = 0ECH								
	CCAP3L = 0EDH								
	CCAP4L = 0EEH								
Reset value		0	0	0	0	0	0	0	0

Table 7. CH: PCA Counter High

CH Address 0F9H	7	6	5	4	3	2	1	0
Reset value	0	0	0	0	0	0	0	0

Table 8. CL: PCA Counter Low

CL Address 0E9H	7	6	5	4	3	2	1	0
Reset value	0	0	0	0	0	0	0	0

PCA Capture Mode

To use one of the PCA modules in the capture mode either one or both of the CCAPM bits CAPN and CAPP for that module must be set. The external CEX input for the module (on port 1) is sampled for a transition. When a valid transition occurs the PCA hardware loads the value of the PCA counter registers (CH and CL) into the module's capture registers (CCAPnL and CCAPnH). If the CCFn bit for the module in the CCON SFR and the ECCFn bit in the CCAPMn SFR are set then an interrupt will be generated (see Figure 21).

Figure 3. PCA Capture Mode

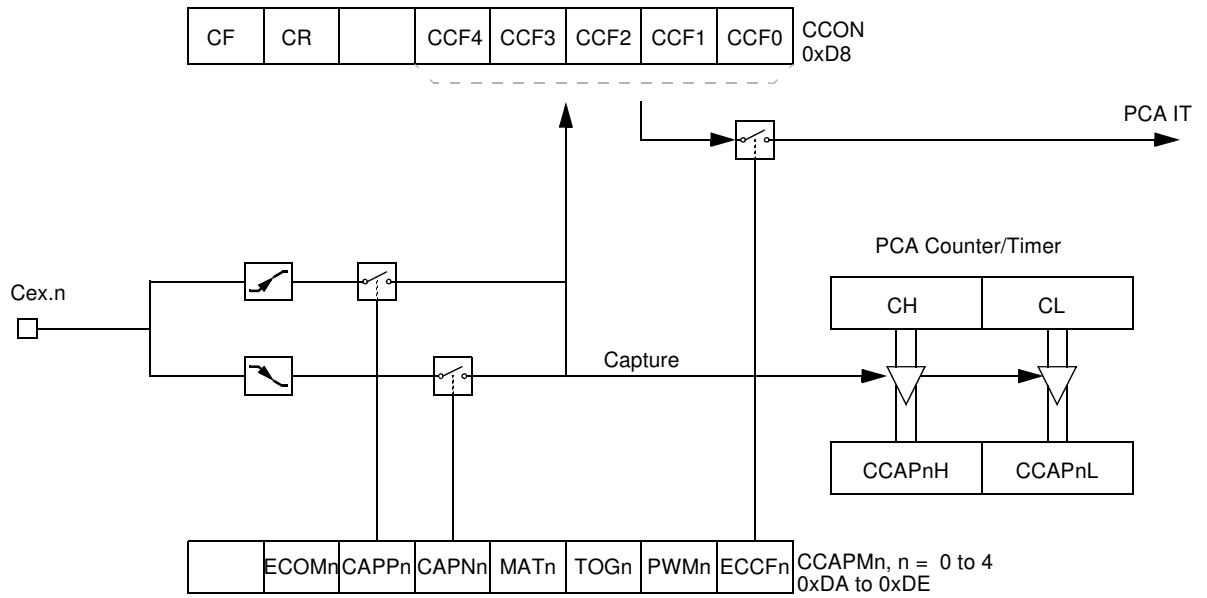

16-bit Software Timer/ Compare Mode

The PCA modules can be used as software timers by setting both the ECOM and MAT bits in the modules CCAPMn register. The PCA timer will be compared to the module's capture registers and when a match occurs an interrupt will occur if the CCFn (CCON SFR) and the ECCFn (CCAPMn SFR) bits for the module are both set (See Figure 22).

Figure 4. PCA Compare Mode and PCA Watchdog Timer

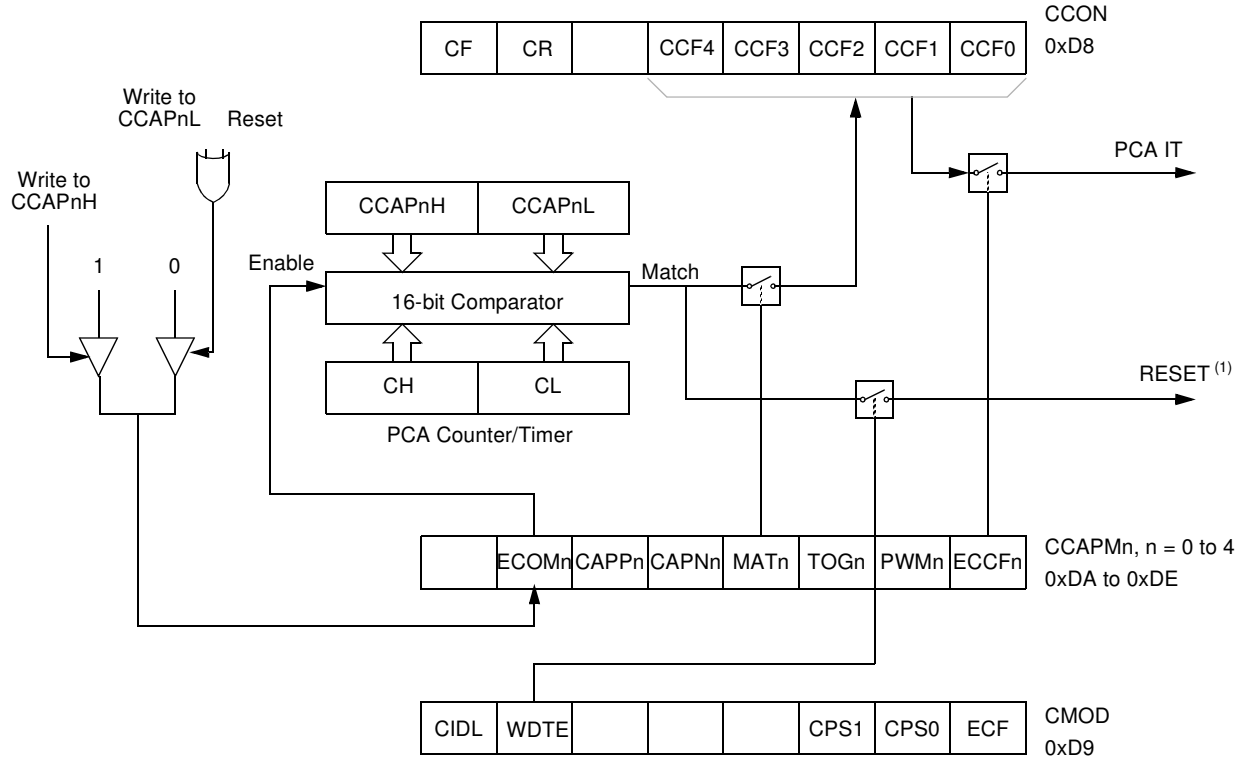

Note: 1. Only for Module 4

Before enabling ECOM bit, CCAPnL and CCAPnH should be set with a non zero value, otherwise an unwanted match could occur. Writing to CCAPnH will set the ECOM bit.

Once ECOM is set, writing CCAPnL will clear ECOM so that an unwanted match doesn't occur while modifying the compare value. Writing to CCAPnH will set ECOM. For this reason, user software should write CCAPnL first, and then CCAPnH. Of course, the ECOM bit can still be controlled by accessing to CCAPMn register.

High-speed Output Mode In this mode the CEX output (on port 1) associated with the PCA module will toggle each time a match occurs between the PCA counter and the module's capture registers. To activate this mode the TOG, MAT, and ECOM bits in the module's CCAPMn SFR must be set (see Figure 23).

A prior write must be done to CCAPnL and CCAPnH before writing the ECOMn bit.

Figure 5. PCA High-speed Output Mode

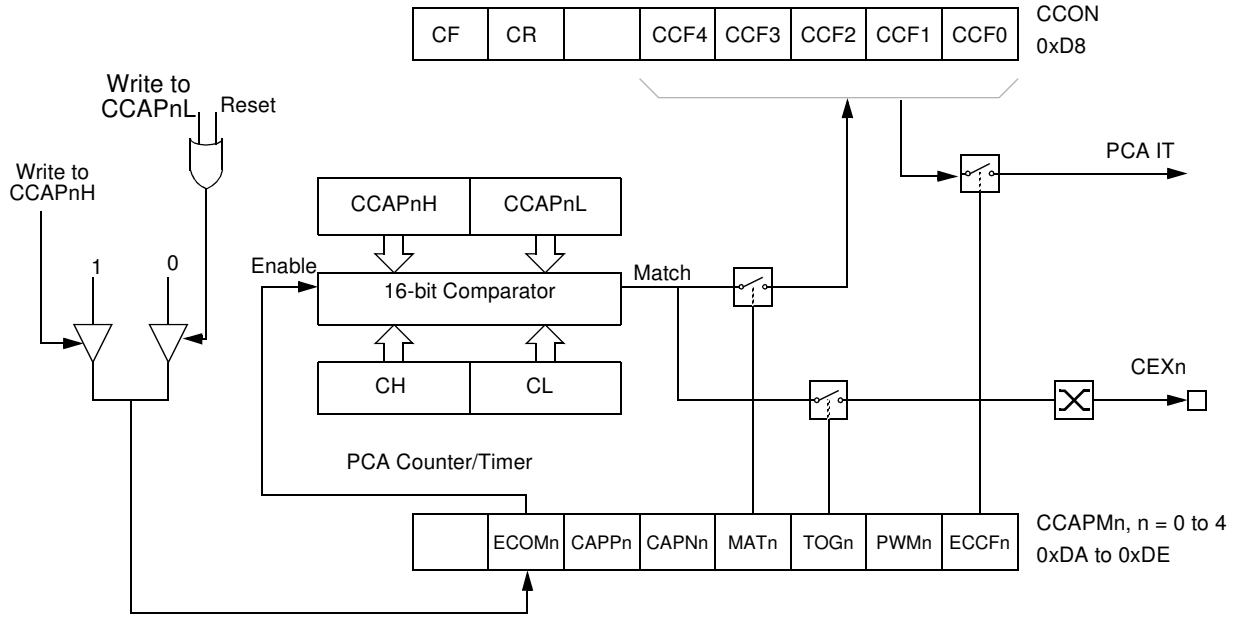

Before enabling ECOM bit, CCAPnL and CCAPnH should be set with a non zero value, otherwise an unwanted match could happen.

Once ECOM is set, writing CCAPnL will clear ECOM so that an unwanted match doesn't occur while modifying the compare value. Writing to CCAPnH will set ECOM. For this reason, user software should write CCAPnL first, and then CCAPnH. Of course, the ECOM bit can still be controlled by accessing to CCAPMn register.

Pulse Width Modulator Mode

All of the PCA modules can be used as PWM outputs. Figure 24 shows the PWM function. The frequency of the output depends on the source for the PCA timer. All of the modules will have the same frequency of output because they all share the PCA timer. The duty cycle of each module is independently variable using the module's capture register CCAPL_n. When the value of the PCA CL SFR is less than the value in the module's CCAPL_n SFR the output will be low, when it is equal to or greater than, the output will be high. When CL overflows from FF to 00, CCAPL_n is reloaded with the value in CCAPH_n. This allows updating the PWM without glitches. The PWM and ECOM bits in the module's CCAPM_n register must be set to enable the PWM mode.

Figure 6. PCA PWM Mode

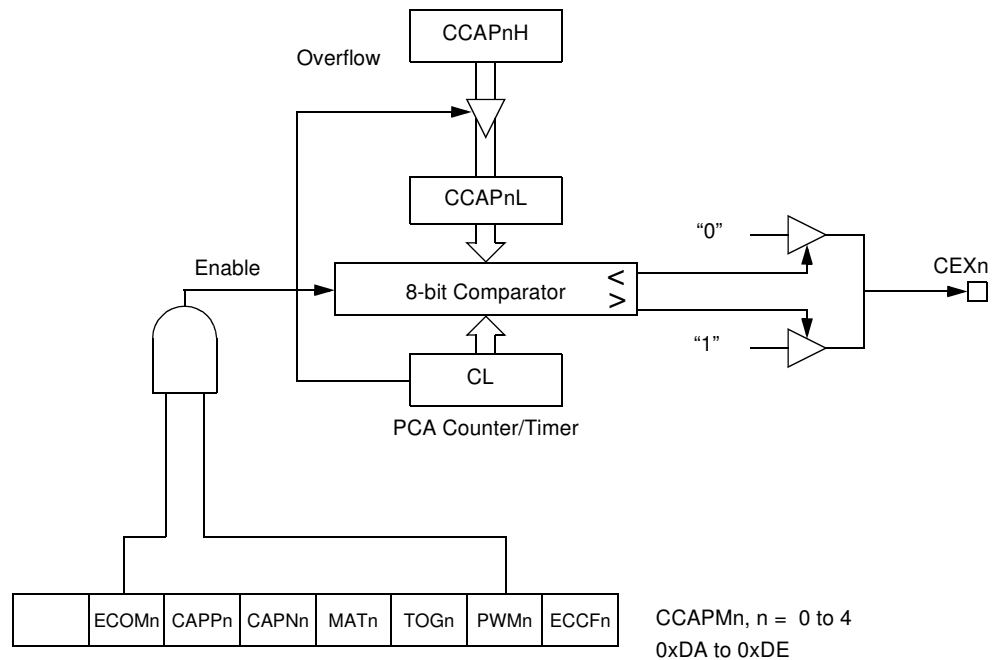

An on-board watchdog timer is available with the PCA to improve the reliability of the system without increasing chip count. Watchdog timers are useful for systems that are susceptible to noise, power glitches, or electrostatic discharge. Module 4 is the only PCA module that can be programmed as a watchdog. However, this module can still be used for other modes if the watchdog is not needed. Figure 22 shows a diagram of how the watchdog works. The user pre-loads a 16-bit value in the compare registers. Just like the other compare modes, this 16-bit value is compared to the PCA timer value. If a match is allowed to occur, an internal reset will be generated. This will not cause the RST pin to be driven high.

In order to hold off the reset, the user has three options:

1. Periodically change the compare value so it will never match the PCA timer
2. Periodically change the PCA timer value so it will never match the compare values or
3. Disable the watchdog by clearing the WDTE bit before a match occurs and then re-enable it

The first two options are more reliable because the watchdog timer is never disabled as in option #3. If the program counter ever goes astray, a match will eventually occur and cause an internal reset. The second option is also not recommended if other PCA modules are being used. Remember, the PCA timer is the time base for all modules; changing the time base for other modules would not be a good idea. Thus, in most applications the first solution is the best option.

This watchdog timer won't generate a reset out on the reset pin.

Analog-to-Digital Converter (ADC)

This section describes the on-chip 10-bit analog-to-digital converter of the T89C51RB2/RC2. Eight ADC channels are available for sampling of the external sources AN0 to AN7. An analog multiplexer allows the single ADC to select one of the 8 ADC channels as ADC input voltage (ADCIN). ADCIN is converted by the 10 bit-cascaded potentiometric ADC.

Three kind of conversions are available:

- Standard conversion (7-8 bits).
- Precision conversion (8-9 bits).
- Accurate conversion (10 bits).

For the precision conversion, set bits PSIDLE and ADSST in ADCON register to start the conversion. The chip is in a pseudo-idle mode, the CPU doesn't run but the peripherals are always running. This mode allows digital noise to be lower, to ensure precise conversion.

For the accurate conversion, set bits QUIETM and ADSST in ADCON register to start the conversion. The chip is in a quiet mode, the AD is the only peripheral running. This mode allows digital noise to be as low as possible, to ensure high precision conversion.

For these modes it is necessary to work with end of conversion interrupt, which is the only way to wake up the chip.

If another interrupt occurs during the precision conversion, it will be treated only after this conversion is ended.

Features

- 8 channels with multiplexed inputs
- 10-bit cascaded potentiometric ADC
- Conversion time down to 10 micro-seconds
- Zero Error (offset) ± 2 LSB max
- External Positive Reference Voltage Range 2.4 to V_{CC}
- ADCIN Range 0 to V_{CC}
- Integral non-linearity typical 1 LSB, max. 2 LSB (with $0.9 \cdot V_{CC} < V_{REF} < V_{CC}$)
- Differential non-linearity typical 0.5 LSB, max. 1 LSB (with $0.9 \cdot V_{CC} < V_{REF} < V_{CC}$)
- Conversion Complete Flag or Conversion Complete Interrupt
- Selected ADC Clock

ADC I/O Functions

AINx are general I/Os that are shared with the ADC channels. The channel select bits in ADCF register define which ADC channel pin will be used as ADCIN. The remaining ADC channels pins can be used as general purpose I/Os or as the alternate function that is available. Writes to the port register which aren't selected by the ADCF will not have any effect.

Figure 1. ADC Description

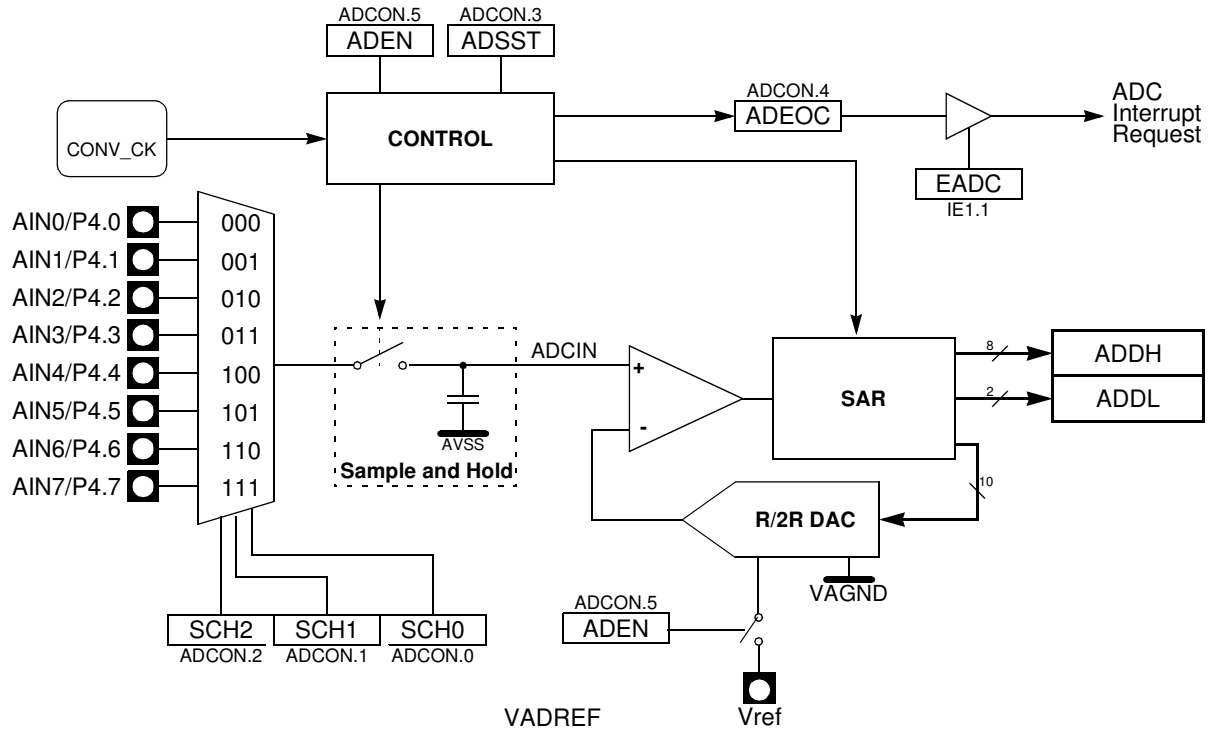
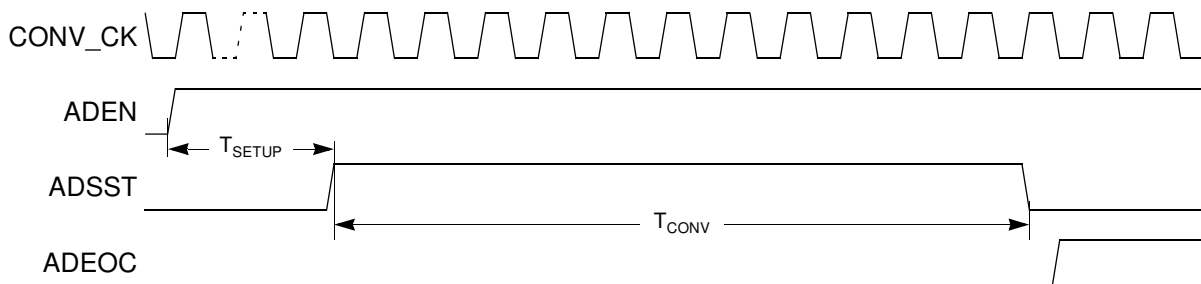

Figure 26 shows the timing diagram of a complete conversion. For simplicity, the figure depicts the waveforms in idealized form and does not provide precise timing information. For ADC characteristics and timing parameters refer to the Section “AC Characteristics” of the AT8xC5111 datasheet.

Figure 2. Timing Diagram



Note: $T_{setup} = 4 \mu s$

ADC Operation

Before starting a conversion, the A/D converter must be enabled, by setting the ADEN bit, for at least T_{setup} (four microseconds).

A start of single A/D conversion is triggered by setting bit ADSST (ADCON.3).

From the ADSST set, the first full CONV_CK period will be the sampling period for the ADC; during this period, the switch is closed and the capacitor is being charged. At the end of the first period, the switch opens and the capacitor is no longer being charged.

During the next 10 CONV_CK periods, the sample and hold will be in hold mode during the conversion. The busy flag ADSST(ADCON.3) remains set as long as an A/D conversion is running. After completion of the A/D conversion, it is cleared by hardware. When a conversion is running, this flag can be read only, a write has no effect.

The end-of-conversion flag ADEOC (ADCON.4) is set when the value of conversion is available in ADDH and ADDL, it is cleared by software. If the bit EADC (IE1.1) is set, an interrupt occur when flag ADEOC is set (see Figure 28). Clear this flag for re-arming the interrupt.

From this point, if you keep starting a new conversion by resetting ADSST without changing ADEN, it is not necessary to wait T_{setup} .

The bits SCH0 to SCH2 in ADCON register are used for the analog input channel selection.

Before starting normal power reduction modes the ADC conversion has to be completed.

Table 1. Selected Analog Input

SCH2	SCH1	SCH0	Selected Analog Input
0	0	0	AN0
0	0	1	AN1
0	1	0	AN2
0	1	1	AN3
1	0	0	AN4
1	0	1	AN5
1	1	0	AN6
1	1	1	AN7

Voltage Conversion

When the ADCIN is equal to VAREF, the ADC converts the signal to 3FFh (full scale). If the input voltage equals VAGND, the ADC converts it to 000h. Input voltage between VAREF and VAGND are a straight-line linear conversion. All other voltages will result in 3FFh if greater than VAREF and 000h if less than VAGND.

Note that ADCIN should not exceed VAREF absolute maximum range.

Clock Selection

The maximum clock frequency for ADC (CONV_CK for Conversion Clock) is defined in the AC characteristics section. A prescaler is featured (ADCCLK) to generate the CONV_CK clock from the oscillator frequency.

Figure 3. A/D Converter Clock

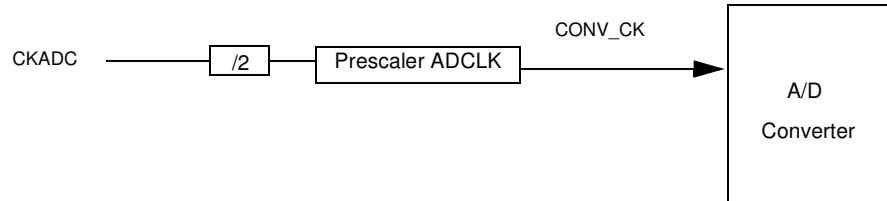

The conversion frequency CONV_CK is derived from the oscillator frequency with the following formulas:

$$F_{CkAdc} = F_{OscOut} / (512 - 2 * CKRL), \text{ if } X2 = 0$$

$$= F_{OscOut}, \text{ if } X2 = 1$$

and

$$F_{CONV_CK} = F_{CkAdc} / (2 * PRS), \text{ if } PRS > 0$$

$$F_{CONV_CK} = F_{CkAdc} / 256, \text{ if } PRS = 0$$

Some examples can be found in the table below:

ADC Standby Mode

F _{OscOut} MHz	X2	CKRL	F _{CkAdc} Mhz	ADCLK	F _{CONV_CK} khz	Conversion time μs
16	0	FF	8	12	333	33
16	1	NA	16	32	250	44

When the ADC is not used, it is possible to set it in standby mode by clearing bit ADEN in ADCON register.

In this mode the power dissipation is about 1 μW.

Voltage Reference

The Vref pin is used to enter the voltage reference for the A/D conversion.

Best accuracy is obtained with $0.9 V_{CC} < V_{REF} < V_{CC}$.

IT ADC Management

An interrupt end-of-conversion will occur when the bit ADEOC is activated and the bit EADC is set. To re-arm the interrupt the bit ADEOC must be cleared by software.

Figure 4. ADC Interrupt Structure

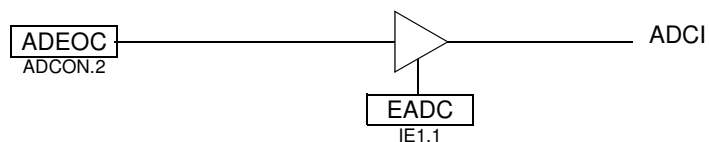

Registers

Table 2. ADCON Register

ADCON (S:F3h)
ADC Control Register

7	6	5	4	3	2	1	0
QUIETM	PSIDLE	ADEN	ADEOC	ADSST	SCH2	SCH1	SCH0
Bit Number	Bit Mnemonic	Description					
7	QUIETM	Pseudo Idle mode (best precision) Set to put in quiet mode during conversion. Cleared by hardware after completion of the conversion.					
6	PSIDLE	Pseudo Idle mode (good precision) Set to put in idle mode during conversion. Cleared by hardware after completion of the conversion.					
5	ADEN	Enable/Standby Mode Set to enable ADC. Clear for Standby mode (power dissipation 1 μ W).					
4	ADEOC	End Of Conversion Set by hardware when ADC result is ready to be read. This flag can generate an interrupt. Must be cleared by software.					
3	ADSST	Start and Status Set to start an A/D conversion. Cleared by hardware after completion of the conversion.					
2 - 0	SCH2:0	Selection of channel to convert See Table 41.					

Reset value = X000 0000b

Table 3. ADCLK Register

ADCLK (S:F2h)
ADC Clock Prescaler

7	6	5	4	3	2	1	0
-	PRS 6	PRS 5	PRS 4	PRS 3	PRS 2	PRS 1	PRS 0
Bit Number	Bit Mnemonic	Description					
7	-	Reserved Leave this bit at 0.					
6 - 0	PRS6:0	Clock Prescaler $f_{CONV_CK} = f_{CKADC} / (2 * PRS)$ if PRS = 0, $f_{CONV_CK} = f_{CKADC} / 256$					

Reset value = 0000 0000b

Table 4. ADDH Register

ADDH (S:F5h Read Only)
ADC Data High byte register

7	6	5	4	3	2	1	0
ADAT 9	ADAT 8	ADAT 7	ADAT 6	ADAT 5	ADAT 4	ADAT 3	ADAT 2
Bit Number	Bit Mnemonic	Description					
7 - 0	ADAT9:2	ADC result Bits 9 - 2					

Read only register
Reset value = 00h

Table 5. ADDL Register

ADDL (S:F4h Read Only)
ADC Data Low byte register

7	6	5	4	3	2	1	0
-	-	-	-	-	-	ADAT 1	ADAT 0
Bit Number	Bit Mnemonic	Description					
7 - 6	-	Reserved The value read from these bits are indeterminate. Do not set these bits.					
1 - 0	ADAT1:0	ADC result Bits 1 - 0					

Read only register
Reset value = xxxx xx00b

Table 6. ADCF Register

ADCF (S:F6h)
ADC Input Select Register

7	6	5	4	3	2	1	0
SEL7	SEL6	SEL5	SEL4	SEL3	SEL2	SEL1	SEL0
Bit Number	Bit Mnemonic	Description					
7 - 0	SEL7 - 0	Select Input 7 - 0 Set to select bit 7 - 0 as possible input for A/D Cleared to leave this bit free for other function					

Interrupt System

The AT8xC5111 has a total of 8 interrupt vectors: two external interrupts ($\overline{\text{INT0}}$ and $\overline{\text{INT1}}$), two timer interrupts (timers 0, 1), serial port interrupt, PCA, SPI and A/D. These interrupts are shown in Figure 29.

Figure 1. Interrupt Control System

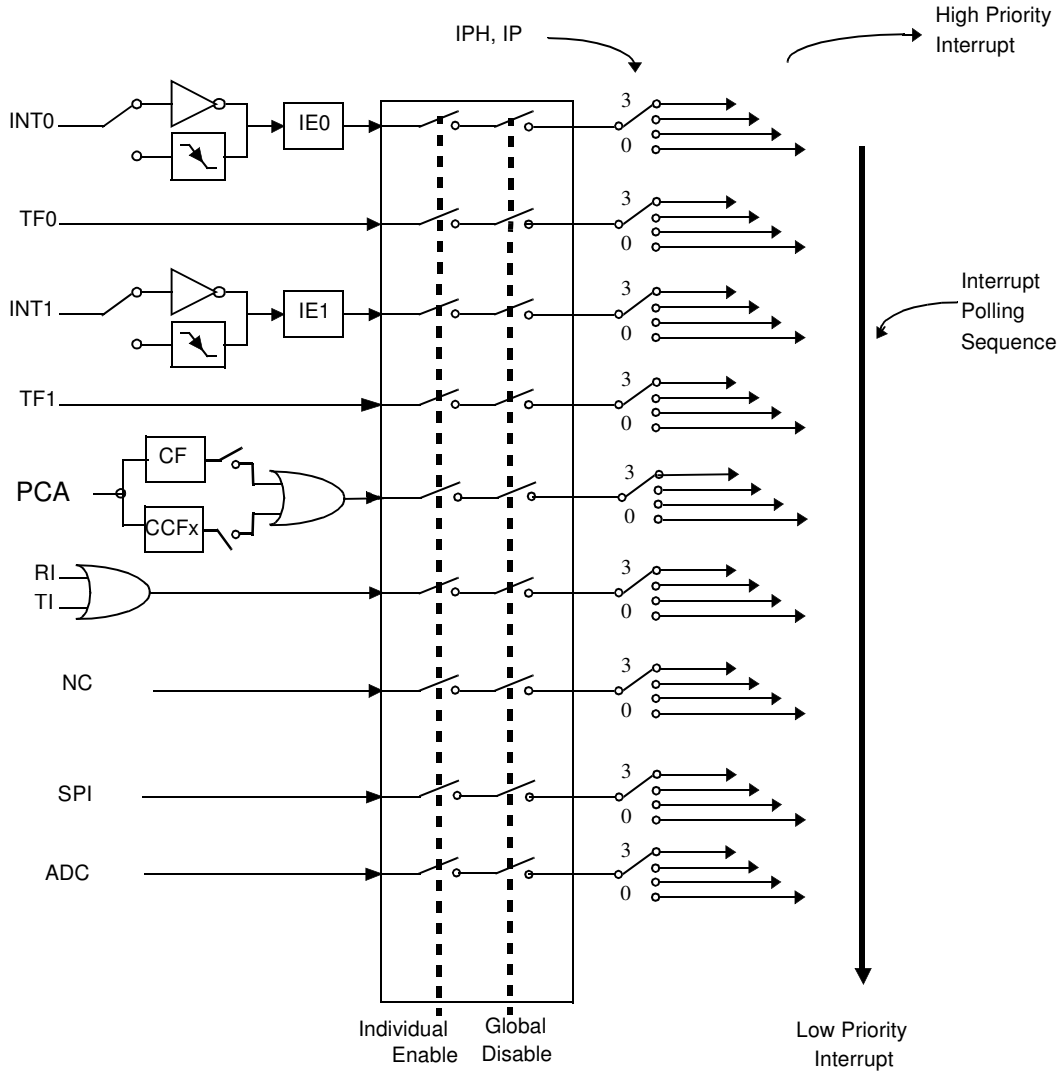

Each of the interrupt sources can be individually enabled or disabled by setting or clearing a bit in the Interrupt Enable register (See Table 49). This register also contains a global disable bit, which must be cleared to disable all interrupts at once.

Each interrupt source can also be individually programmed to one of four priority levels by setting or clearing a bit in the Interrupt Priority register (See Table 51) and in the Interrupt Priority High register (see Table 53). Table 47 shows the bit values and priority levels associated with each combination.

Table 1. Priority Bit Level Values

IPH.x	IP.x	Interrupt Level Priority
0	0	0 (Lowest)
0	1	1
1	0	2
1	1	3 (Highest)

A low-priority interrupt can be interrupted by a high priority interrupt, but not by another low-priority interrupt. A high-priority interrupt can't be interrupted by any other interrupt source.

If two interrupt requests of different priority levels are received simultaneously, the request of higher priority level is serviced. If interrupt requests of the same priority level are received simultaneously, an internal polling sequence determines which request is serviced. Thus within each priority level there is a second priority structure determined by the polling sequence.

Table 2. Address Vectors

Interrupt Name	Interrupt Address Vector	Priority Number
External Interrupt (INT0)	0003h	1
Timer0 (TF0)	000Bh	2
External Interrupt (INT1)	0013h	3
Timer1 (TF1)	001Bh	4
PCA (CF or CCFn)	0033h	5
UART (RI or TI)	0023h	6
SPI	004Bh	8
ADC	0043h	9

Table 3. IE0 Register

IE0 - Interrupt Enable Register (A8H)

7	6	5	4	3	2	1	0
EA	EC	-	ES	ET1	EX1	ET0	EX0
Bit Number	Bit Mnemonic	Description					
7	EA	Enable All interrupt bit Clear to disable all interrupts. Set to enable all interrupts. If EA = 1, each interrupt source is individually enabled or disabled by setting or clearing its interrupt enable bit.					
6	EC	PCA Interrupt Enable Clear to disable the the PCA interrupt. Set to enable the the PCA interrupt.					
5	-	Reserved The value read from this bit is indeterminate. Do not set this bit.					
4	ES	Serial port Enable bit Clear to disable serial port interrupt. Set to enable serial port interrupt.					
3	ET1	Timer 1 overflow interrupt Enable bit Clear to disable timer 1 overflow interrupt. Set to enable timer 1 overflow interrupt.					
2	EX1	External interrupt 1 Enable bit Clear to disable external interrupt 1. Set to enable external interrupt 1.					
1	ET0	Timer 0 overflow interrupt Enable bit Clear to disable timer 0 overflow interrupt. Set to enable timer 0 overflow interrupt.					
0	EX0	External interrupt 0 Enable bit Clear to disable external interrupt 0. Set to enable external interrupt 0.					

Reset value = 00X0 0000b

Bit addressable

Table 4. IE1 Register

IE1 (S:B1H) - Interrupt Enable Register

7	6	5	4	3	2	1	0
-	-	-	-	-	ESPI	EADC	-
Bit Number	Bit Mnemonic	Description					
7	-	Reserved The value read from this bit is indeterminate. Do not set this bit.					
6	-	Reserved The value read from this bit is indeterminate. Do not set this bit.					
5	-	Reserved The value read from this bit is indeterminate. Do not set this bit.					
4	-	Reserved The value read from this bit is indeterminate. Do not set this bit.					
3	-	Reserved The value read from this bit is indeterminate. Do not set this bit.					
2	ESPI	SPI Interrupt Enable bit Clear to disable the SPI interrupt. Set to enable the SPI interrupt.					
1	EADC	A/D Interrupt Enable bit Clear to disable the ADC interrupt. Set to enable the ADC interrupt.					
0	-	Reserved The value read from this bit is indeterminate. Do not set this bit.					

Reset value = XXXX X00Xb

No Bit addressable

Table 5. IPL0 Register

IPL0 - Interrupt Priority Register (B8H)

7	6	5	4	3	2	1	0
-	PPC	-	PS	PT1	PX1	PT0	PX0
Bit Number	Bit Mnemonic	Description					
7	-	Reserved The value read from this bit is indeterminate. Do not set this bit.					
6	PPC	PCA Counter Interrupt Priority bit Refer to PPCH for priority level.					
5	-	Reserved The value read from this bit is indeterminate. Do not set this bit.					
4	PS	Serial port Priority bit Refer to PSH for priority level.					
3	PT1	Timer 1 overflow interrupt Priority bit Refer to PT1H for priority level.					
2	PX1	External interrupt 1 Priority bit Refer to PX1H for priority level.					
1	PT0	Timer 0 overflow interrupt Priority bit Refer to PT0H for priority level.					
0	PX0	External interrupt 0 Priority bit Refer to PX0H for priority level.					

Reset value = X0X0 0000b

Bit addressable.

Table 6. IPL1 Register

IPL1 - Interrupt Priority Low Register 1 (S:B2H)

7	6	5	4	3	2	1	0
-	-	-	-	-	PSPI	PADC	-

Bit Number	Bit Mnemonic	Description
7	-	Reserved The value read from this bit is indeterminate. Do not set this bit.
6	-	Reserved The value read from this bit is indeterminate. Do not set this bit.
5	-	Reserved The value read from this bit is indeterminate. Do not set this bit.
4	-	Reserved The value read from this bit is indeterminate. Do not set this bit.
3	-	Reserved The value read from this bit is indeterminate. Do not set this bit.
2	PSPI	SPI Interrupt Priority level less significant bit. Refer to PSPIH for priority level.
1	PADC	ADC Interrupt Priority level less significant bit. Refer to PADCH for priority level.
0	-	Reserved The value read from this bit is indeterminate. Do not set this bit.

Reset value = XXXX X00Xb

Not Bit addressable.

Table 7. IPH0 Register

IPH0 - Interrupt Priority High Register

	7	6	5	4	3	2	1	0
	-	PPCH	-	PSH	PT1H	PX1H	PT0H	PX0H

Bit Number	Bit Mnemonic	Description															
7	-	Reserved The value read from this bit is indeterminate. Do not set this bit.															
6	PPCH	PCA Counter Interrupt Priority level most significant bit <table style="width: 100%; border-collapse: collapse;"> <tr> <td style="border: none;">PPCH</td> <td style="border: none;">PPC</td> <td style="border: none;">Priority Level</td> </tr> <tr> <td style="border: none;">0</td> <td style="border: none;">0</td> <td style="border: none;">Lowest</td> </tr> <tr> <td style="border: none;">0</td> <td style="border: none;">1</td> <td style="border: none;"></td> </tr> <tr> <td style="border: none;">1</td> <td style="border: none;">0</td> <td style="border: none;"></td> </tr> <tr> <td style="border: none;">1</td> <td style="border: none;">1</td> <td style="border: none;">Highest</td> </tr> </table>	PPCH	PPC	Priority Level	0	0	Lowest	0	1		1	0		1	1	Highest
PPCH	PPC	Priority Level															
0	0	Lowest															
0	1																
1	0																
1	1	Highest															
5	-	Reserved The value read from this bit is indeterminate. Do not set this bit.															
4	PSH	Serial port Priority High bit <table style="width: 100%; border-collapse: collapse;"> <tr> <td style="border: none;">PSH</td> <td style="border: none;">PS</td> <td style="border: none;">Priority Level</td> </tr> <tr> <td style="border: none;">0</td> <td style="border: none;">0</td> <td style="border: none;">Lowest</td> </tr> <tr> <td style="border: none;">0</td> <td style="border: none;">1</td> <td style="border: none;"></td> </tr> <tr> <td style="border: none;">1</td> <td style="border: none;">0</td> <td style="border: none;"></td> </tr> <tr> <td style="border: none;">1</td> <td style="border: none;">1</td> <td style="border: none;">Highest</td> </tr> </table>	PSH	PS	Priority Level	0	0	Lowest	0	1		1	0		1	1	Highest
PSH	PS	Priority Level															
0	0	Lowest															
0	1																
1	0																
1	1	Highest															
3	PT1H	Timer 1 overflow interrupt Priority High bit <table style="width: 100%; border-collapse: collapse;"> <tr> <td style="border: none;">PT1H</td> <td style="border: none;">PT1</td> <td style="border: none;">Priority Level</td> </tr> <tr> <td style="border: none;">0</td> <td style="border: none;">0</td> <td style="border: none;">Lowest</td> </tr> <tr> <td style="border: none;">0</td> <td style="border: none;">1</td> <td style="border: none;"></td> </tr> <tr> <td style="border: none;">1</td> <td style="border: none;">0</td> <td style="border: none;"></td> </tr> <tr> <td style="border: none;">1</td> <td style="border: none;">1</td> <td style="border: none;">Highest</td> </tr> </table>	PT1H	PT1	Priority Level	0	0	Lowest	0	1		1	0		1	1	Highest
PT1H	PT1	Priority Level															
0	0	Lowest															
0	1																
1	0																
1	1	Highest															
2	PX1H	External interrupt 1 Priority High bit <table style="width: 100%; border-collapse: collapse;"> <tr> <td style="border: none;">PX1H</td> <td style="border: none;">PX1</td> <td style="border: none;">Priority Level</td> </tr> <tr> <td style="border: none;">0</td> <td style="border: none;">0</td> <td style="border: none;">Lowest</td> </tr> <tr> <td style="border: none;">0</td> <td style="border: none;">1</td> <td style="border: none;"></td> </tr> <tr> <td style="border: none;">1</td> <td style="border: none;">0</td> <td style="border: none;"></td> </tr> <tr> <td style="border: none;">1</td> <td style="border: none;">1</td> <td style="border: none;">Highest</td> </tr> </table>	PX1H	PX1	Priority Level	0	0	Lowest	0	1		1	0		1	1	Highest
PX1H	PX1	Priority Level															
0	0	Lowest															
0	1																
1	0																
1	1	Highest															
1	PT0H	Timer 0 overflow interrupt Priority High bit <table style="width: 100%; border-collapse: collapse;"> <tr> <td style="border: none;">PT0H</td> <td style="border: none;">PT0</td> <td style="border: none;">Priority Level</td> </tr> <tr> <td style="border: none;">0</td> <td style="border: none;">0</td> <td style="border: none;">Lowest</td> </tr> <tr> <td style="border: none;">0</td> <td style="border: none;">1</td> <td style="border: none;"></td> </tr> <tr> <td style="border: none;">1</td> <td style="border: none;">0</td> <td style="border: none;"></td> </tr> <tr> <td style="border: none;">1</td> <td style="border: none;">1</td> <td style="border: none;">Highest</td> </tr> </table>	PT0H	PT0	Priority Level	0	0	Lowest	0	1		1	0		1	1	Highest
PT0H	PT0	Priority Level															
0	0	Lowest															
0	1																
1	0																
1	1	Highest															
0	PX0H	External interrupt 0 Priority High bit <table style="width: 100%; border-collapse: collapse;"> <tr> <td style="border: none;">PX0H</td> <td style="border: none;">PT0</td> <td style="border: none;">Priority Level</td> </tr> <tr> <td style="border: none;">0</td> <td style="border: none;">0</td> <td style="border: none;">Lowest</td> </tr> <tr> <td style="border: none;">0</td> <td style="border: none;">1</td> <td style="border: none;"></td> </tr> <tr> <td style="border: none;">1</td> <td style="border: none;">0</td> <td style="border: none;"></td> </tr> <tr> <td style="border: none;">1</td> <td style="border: none;">1</td> <td style="border: none;">Highest</td> </tr> </table>	PX0H	PT0	Priority Level	0	0	Lowest	0	1		1	0		1	1	Highest
PX0H	PT0	Priority Level															
0	0	Lowest															
0	1																
1	0																
1	1	Highest															

Reset value = X0X0 0000b

Not bit addressable

Table 8. IPH1 Register
IPH1 - Interrupt High Register 1 (B3H)

	7	6	5	4	3	2	1	0
	-	-	-	-	-	PSP1H	PADCH	-

Bit Number	Bit Mnemonic	Description															
7	-	Reserved The value read from this bit is indeterminate. Do not set this bit.															
6	-	Reserved The value read from this bit is indeterminate. Do not set this bit.															
5	-	Reserved The value read from this bit is indeterminate. Do not set this bit.															
4	-	Reserved The value read from this bit is indeterminate. Do not set this bit.															
3	-	Reserved The value read from this bit is indeterminate. Do not set this bit.															
2	PSP1H	SPI Interrupt Priority level most significant bit <table style="width: 100%; border-collapse: collapse;"> <thead> <tr> <th style="text-align: left;"><u>PSP1H</u></th> <th style="text-align: left;"><u>PSP1</u></th> <th style="text-align: left;"><u>Priority Level</u></th> </tr> </thead> <tbody> <tr> <td>0</td> <td>0</td> <td>Lowest</td> </tr> <tr> <td>0</td> <td>1</td> <td></td> </tr> <tr> <td>1</td> <td>0</td> <td></td> </tr> <tr> <td>1</td> <td>1</td> <td>Highest</td> </tr> </tbody> </table>	<u>PSP1H</u>	<u>PSP1</u>	<u>Priority Level</u>	0	0	Lowest	0	1		1	0		1	1	Highest
<u>PSP1H</u>	<u>PSP1</u>	<u>Priority Level</u>															
0	0	Lowest															
0	1																
1	0																
1	1	Highest															
1	PADCH	ADC Interrupt Priority level most significant bit <table style="width: 100%; border-collapse: collapse;"> <thead> <tr> <th style="text-align: left;"><u>PADCH</u></th> <th style="text-align: left;"><u>PADC</u></th> <th style="text-align: left;"><u>Priority Level</u></th> </tr> </thead> <tbody> <tr> <td>0</td> <td>0</td> <td>Lowest</td> </tr> <tr> <td>0</td> <td>1</td> <td></td> </tr> <tr> <td>1</td> <td>0</td> <td></td> </tr> <tr> <td>1</td> <td>1</td> <td>Highest</td> </tr> </tbody> </table>	<u>PADCH</u>	<u>PADC</u>	<u>Priority Level</u>	0	0	Lowest	0	1		1	0		1	1	Highest
<u>PADCH</u>	<u>PADC</u>	<u>Priority Level</u>															
0	0	Lowest															
0	1																
1	0																
1	1	Highest															
0	-	Reserved The value read from this bit is indeterminate. Do not set this bit.															

Reset value = XXXX X00Xb
Not bit addressable

ROM

ROM Structure

The AT83C5112 ROM memory is divided in three different arrays:

- The code array: 4K Bytes
- The encryption array: 64 bytes
- The signature array:..... 4 bytes
- ROM Lock System

The program Lock system, when programmed, protects the on-chip program against software piracy.

Encryption Array

Within the ROM array there are 64 bytes of encryption array. Every time a byte is addressed during program verify, 6 address lines are used to select a byte of the encryption array. This byte is then exclusive-NOR'ed (XNOR) with the code byte, creating an encrypted verify byte. The algorithm, with the encryption array in the unprogrammed state, will return the code in its original, unmodified form.

When using the encryption array, one important factor needs to be considered. If a byte has the value FFh, verifying the byte will produce the encryption byte value. If a large block (>64 bytes) of code is left unprogrammed, a verification routine will display the content of the encryption array. For this reason all the unused code bytes should be programmed with random values.

Configuration Byte

The configuration byte is a special register. Its content, described in paragraph Section “Registers”, page 10 is defined by the diffusion mask in the ROM version or written by the OTP programmer in the OTP version.

The lock bits when programmed according to Table 55 will provide different levels of protection for the on-chip code and data.

Table 1. Program Lock Bits

Program Lock Bits			Protection Description
Security Level	LB1	LB2	
1	U	U	No program lock features enabled. Code verify will still be encrypted by the encryption array if programmed. MOVC instruction returns non encrypted data.
2	P	U	Same as 1
3	U	P	Same as 2, also verify is disabled. This security level is available because ROM integrity will be verified thanks to another method*.

Notes: 1. U: unprogrammed
2. P: programmed

*Warning: When security bit is set, ROM content cannot be verified. Only the CRC is verified.

Signature Bytes

The T80C5111 contains 4 factory programmed signature bytes. To read these bytes, perform the process described in Section “Signature Bytes Content”, page 69.

Verify Algorithm

Refer to Section “Verify Algorithm”, page 68.

Program Code Mapping

As there is no external capability in LPC packages, the code size is limited to 4K Bytes. Any access above 4K will be mapped in the first 4K segment (0XXXh).

EPROM

EPROM Programming

Specific algorithm is implemented, use qualified device programmers from third party vendors.

EPROM Erasure (Windowed Packages Only)

Erasing the EPROM erases the code array, the encryption array and the lock bits returning the parts to full functionality.

Erasure leaves all the EPROM cells in a 1's state (FF).

Erasure Characteristics

The recommended erasure procedure is exposure to ultraviolet light (at 2537 Å) to an integrated dose at least 15 W-sec/cm². Exposing the EPROM to an ultraviolet lamp of 12,000 μW/cm² rating for 30 minutes, at a distance of about 25 mm, should be sufficient. An exposure of 1 hour is recommended with most of standard erasers.

Erasure of the EPROM begins to occur when the chip is exposed to light with wavelength shorter than approximately 4,000 Å. Since sunlight and fluorescent lighting have wavelengths in this range, exposure to these light sources over an extended time (about 1 week in sunlight, or 3 years in room-level fluorescent lighting) could cause inadvertent erasure. If an application subjects the device to this type of exposure, it is suggested that an opaque label be placed over the window.

Signature Bytes

Signature Bytes Content

The AT8xC5111 has four signature bytes in location 30h, 31h, 60h and 61h. To read these bytes follow the procedure for EPROM signature bytes reading. Table 56. shows the content of the signature byte for the AT8xC5111.

Table 1. Signature Bytes Content

Location	Contents	Comment
30h	58h	Manufacturer Code: Atmel
31h	57h	Family Code: C51 X2
60h	2Eh	Product name: AT8xC5111 4K ROM version
60h	A Eh	Product name: AT8xC5111 4K OTP version
61h	E Fh	Product revision number: AT8xC5111 Rev.0

Configuration Byte

The configuration byte is a special register. Its content is defined by the diffusion mask in the ROM version or is read or written by the OTP programmer in the OTP version. This register can also be accessed as a read only register.

Table 2. Configuration Byte - CONF (EFh)

7	6	5	4	3	2	1	0
LB1	LB2	LB3	1	1	1	1	1

Bit Number	Bit Mnemonic	Description
7:5	-	Program memory lock bits See previous chapter for the definition of these bits.
4	-	Reserved Leave this bit at 1.
3	-	Reserved Leave this bit at 1.
2	-	Reserved Leave this bit at 1.
1	-	Reserved Leave this bit at 1.
0	-	Reserved Leave this bit at 1.

Reset value = 1111 111X

Electrical Characteristics

Absolute Maximum Ratings ⁽¹⁾

C = Commercial.....	0°C to 70°C
I = Industrial.....	-40°C to 85°C
Storage Temperature.....	-65°C to +150°C
Voltage on V _{CC} to V _{SS}	-0.5V to +7V
Voltage on V _{PP} to V _{SS}	-0.5V to +13V
Voltage on Any Pin to V _{SS}	-0.5V to V _{CC} +0.5V
Power Dissipation.....	1 W ⁽²⁾

- Notes:
1. Stresses at or above those listed under “ Absolute Maximum Ratings” may cause permanent damage to the device. This is a stress rating only and functional operation of the device at these or any other conditions above those indicated in the operational sections of this specification is not implied. Exposure to absolute maximum rating conditions may affect device reliability.
 2. This value is based on the maximum allowable die temperature and the thermal resistance of the package.

Power Consumption Measurement

Since the introduction of the first C51 devices, every manufacturer made operating I_{CC} measurements under reset, which made sense for the designs where the CPU was running under reset. In our new devices, the CPU is no longer active during reset, so the power consumption is very low but is not really representative of what will happen in the customer system. That’s why, while keeping measurements under Reset, we present a new way to measure the operating I_{CC}:

Using an internal test ROM, the following code is executed:

Label: SJMP Label (80 FE)

Ports 1, 3, 4 are disconnected, RST = V_{CC}, XTAL2 is not connected and XTAL1 is driven by the clock.

This is much more representative of the real operating I_{CC}.

DC Parameters for Standard Voltage

Table 1. DC Parameters in Standard Voltage

$T_A = -40^{\circ}\text{C}$ to $+85^{\circ}\text{C}$; $V_{SS} = 0\text{ V}$; $V_{CC} = 5\text{ V} \pm 10\%$

Symbol	Parameter	Min	Typ	Max	Unit	Test Conditions
V_{IL}	Input Low Voltage	-0.5		$0.2 V_{CC} - 0.1$	V	
V_{IH}	Input High Voltage except XTAL1, RST	$0.2 V_{CC} + 0.9$		$V_{CC} + 0.5$	V	
V_{IH1}	Input High Voltage, XTAL1, RST	$0.7 V_{CC}$		$V_{CC} + 0.5$	V	
V_{OL}	Output Low Voltage, ports 1, 3, 4. ⁽⁶⁾			0.3	V	$I_{OL} = 100\ \mu\text{A}$
				0.45	V	$I_{OL} = 1.6\ \text{mA}$
				1.0	V	$I_{OL} = 3.5\ \text{mA}$
V_{OH}	Output High Voltage, ports 1, 3, 4. ⁽⁶⁾ mode pseudo bidirectionnel	$V_{CC} - 0.3$			V	$I_{OH} = -10\ \mu\text{A}$
		$V_{CC} - 0.7$			V	$I_{OH} = -30\ \mu\text{A}$
		$V_{CC} - 1.5$			V	$I_{OH} = -60\ \mu\text{A}$ $V_{CC} = 5\text{ V} \pm 10\%$
V_{OH2}	Output High Voltage, ports 1, 3, 4. ⁽⁶⁾ Mode Push pull	$V_{CC} - 0.3$			V	$I_{OH} = -100\ \mu\text{A}$
		$V_{CC} - 0.7$			V	$I_{OH} = -1.6\ \text{mA}$
	Off impedance, ports 1, 3, 4.		6		M Ω	$I_{OH} = -3.2\ \text{mA}$ $V_{CC} = 5\text{ V} \pm 10\%$
R_{RST}	RST Pullup Resistor	50	90 ⁽⁵⁾	200	k Ω	
I_{IL}	Logic 0 Input Current ports 1, 3 and 4			-50 TBD	μA	$V_{IN} = 0.45\text{V}$, port 1 & 3 $V_{IN} = 0.45\text{V}$, port 4
I_{LI}	Input Leakage Current			± 10	μA	$0.45\text{V} < V_{IN} < V_{CC}$
I_{TL}	Logic 1 to 0 Transition Current, ports 1, 3, 4			-650	μA	$V_{IN} = 2.0\ \text{V}$
C_{IO}	Capacitance of I/O Buffer			10	pF	$F_c = 1\ \text{MHz}$ $T_A = 25^{\circ}\text{C}$
I_{PD}	Power-down Current	to be confirmed	20 ⁽⁵⁾	50	μA	$2.0\text{V} < V_{CC} < 5.5\text{V}$ ⁽³⁾
I_{CC} under RESET	Power Supply Current Maximum values, X1 mode ⁽⁷⁾		to be confirmed	3+ 0.4 Freq (MHz) 5.8 at 12 MHz 7.4 at 16 MHz	mA	$V_{CC} = 5.5\text{V}$ (1)
I_{CC} operat ing	Power Supply Current Maximum values, X1 mode ⁽⁷⁾		to be confirmed	3 + 0.6 Freq (MHz) 10.2 at 12 MHz 12.6 at 16 MHz	mA	$V_{CC} = 5.5\text{V}$ ⁽⁸⁾
I_{CC} idle	Power Supply Current Maximum values, X1 mode ⁽⁷⁾		to be confirmed	3 + 0.3 Freq (MHz) 3.9 at 12 MHz 5.1 at 16 MHz	mA	$V_{CC} = 5.5\text{V}$ ⁽²⁾
I_{CC} operat ing	Power Supply Current OSCB		to be confirmed	6	mA	$V_{CC} = 5.5\text{V}$ ⁽⁸⁾ , at 12 MHz
V_{RET}	Supply voltage during power-down mode	2			V	

DC Parameters for Low Voltage

Table 2. DC Parameters in Standard Voltage

$T_A = -40^{\circ}\text{C}$ to $+85^{\circ}\text{C}$; $V_{SS} = 0\text{ V}$; $V_{CC} = 2.7$ to 5.5V

Symbol	Parameter	Min	Typ	Max	Unit	Test Conditions
V_{IL}	Input Low Voltage	-0.5		$0.2 V_{CC} - 0.1$	V	
V_{IH}	Input High Voltage except XTAL1, RST	$0.2 V_{CC} + 0.9$		$V_{CC} + 0.5$	V	
V_{IH1}	Input High Voltage, XTAL1, RST	$0.7 V_{CC}$		$V_{CC} + 0.5$	V	
V_{OL}	Output Low Voltage, ports 1, 3, 4. ⁽⁶⁾			0.3	V	$I_{OL} = 100\ \mu\text{A}$
				0.45	V	$I_{OL} = 0.8\text{mA}$
				1.0	V	$I_{OL} = 1.6\text{mA}$
V_{OH}	Output High Voltage, ports 1, 3, 4. ⁽⁶⁾ mode pseudo bi-directional	$V_{CC} - 0.3$			V	$I_{OH} = -10\ \mu\text{A}$
		$V_{CC} - 0.7$			V	$I_{OH} = -30\ \mu\text{A}$
		$V_{CC} - 1.5$			V	$I_{OH} = -60\ \mu\text{A}$
V_{OH2}	Output High Voltage, ports 1, 3, 4. ⁽⁶⁾ Mode Push pull	$V_{CC} - 0.3$			V	$I_{OH} = -100\ \mu\text{A}$
		$V_{CC} - 0.7$			V	$I_{OH} = -0.8\ \text{mA}$
		$V_{CC} - 1.5$			V	$I_{OH} = -1.6\ \text{mA}$
	Off impedance, ports 1, 3, 4.		6		M Ω	
R_{RST}	RST Pullup Resistor	50	90 ⁽⁵⁾	200	k Ω	
I_{IL}	Logic 0 Input Current ports 1, 3 and 4			-50 TBD	μA	$V_{IN} = 0.45\text{V}$, port 1 & 3 $V_{IN} = 0.45\text{V}$, port 4
I_{LI}	Input Leakage Current			± 10	μA	$0.45\text{V} < V_{IN} < V_{CC}$
I_{TL}	Logic 1 to 0 Transition Current, ports 1, 3, 4			-650	μA	$V_{IN} = 2.0\text{V}$
C_{IO}	Capacitance of I/O Buffer			10	pF	$F_C = 1\ \text{MHz}$ $T_A = 25^{\circ}\text{C}$
I_{PD}	Power-down Current	to be confirmed	20 ⁽⁵⁾	50	μA	$2.0\text{V} < V_{CC} < 5.5\text{V}$ ⁽³⁾
I_{CC} under RESET	Power Supply Current Maximum values, X1 mode ⁽⁷⁾		TBD	1.5+ 0.2 Freq (MHz) 3.4 at 12 MHz 4.2 at 16 MHz	mA	$V_{CC} = 3.3\text{V}$ (1)
I_{CC} operating	Power Supply Current Maximum values, X1 mode ⁽⁷⁾		TBD	1.5 + 0.3 Freq (MHz) 5.1 at 12 MHz 6.3 at 16 MHz	mA	$V_{CC} = 3.3\text{V}$ ⁽⁸⁾
I_{CC} idle	Power Supply Current Maximum values, X1 mode ⁽⁷⁾		TBD	1.5 + 0.15 Freq (MHz) 2 at 12 MHz 2.6 at 16 MHz	mA	$V_{CC} = 3.3\text{V}$ ⁽²⁾
I_{CC} operating	Power Supply Current OSCB		TBD	3	mA	$V_{CC} = 3.3\text{V}$ ⁽⁸⁾ , at 12MHz
V_{RET}	Supply voltage during power-down mode	2			V	

- Notes:
- I_{CC} under reset is measured with all output pins disconnected; XTAL1 driven with T_{CLCH} , $T_{CHCL} = 5\ \text{ns}$ (see Figure 34.), $V_{IL} = V_{SS} + 0.5\text{V}$, $V_{IH} = V_{CC} - 0.5\text{V}$; XTAL2 N.C.; $V_{PP} = RST = V_{CC}$. I_{CC} would be slightly higher if a crystal oscillat or used
 - Idle I_{CC} is measured with all output pins disconnected; XTAL1 driven with T_{CLCH} , $T_{CHCL} = 5\ \text{ns}$, $V_{IL} = V_{SS} + 0.5\text{V}$, $V_{IH} = V_{CC} - 0.5\text{V}$; XTAL2 N.C.; $V_{PP} = RST = V_{SS}$ (see Figure 32.).
 - Power-down I_{CC} is measured with all output pins disconnected; $V_{PP} = V_{SS}$; XTAL2 NC.; $RST = V_{SS}$ (see Figure 33.).
 - Not Applicable.
 - Typicals are based on a limited number of samples and are not guaranteed. The values listed are at room temperature and 5V.

6. If I_{OL} exceeds the test condition, V_{OL} may exceed the related specification. Pins are not guaranteed to sink current greater than the listed test conditions.
7. For other values, please contact your sales office.
8. Operating I_{CC} is measured with all output pins disconnected; XTAL1 driven with T_{CLCH} , $T_{CHCL} = 5$ ns (see Figure 34.), $V_{IL} = V_{SS} + 0.5V$, $V_{IH} = V_{CC} - 0.5V$; XTAL2 N.C.; $\overline{RST}/V_{PP} = V_{CC}$; The internal ROM runs the code 80 FE (label: SJMP label). I_{CC} would be slightly higher if a crystal oscillator is used. Measurements are made with OTP products when possible, which is the worst case.

Figure 1. I_{CC} Test Condition, Under Reset

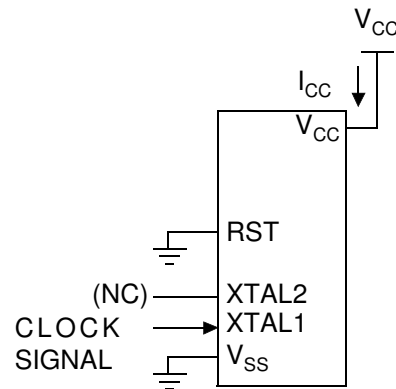

All other pins are disconnected.

Figure 2. Operating I_{CC} Test Condition

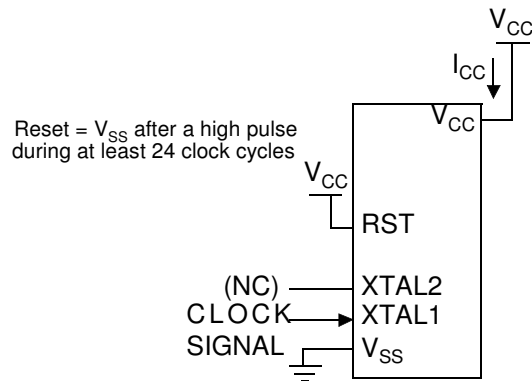

All other pins are disconnected.

Figure 3. I_{CC} Test Condition, Idle Mode

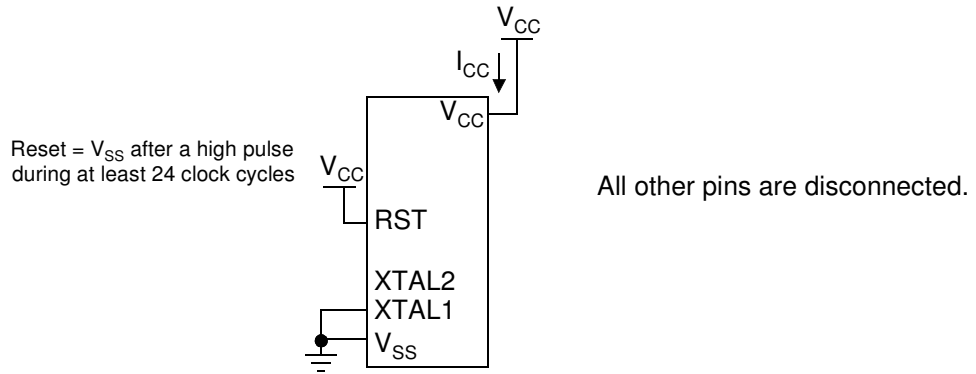

Figure 4. I_{CC} Test Condition, Power-Down Mode

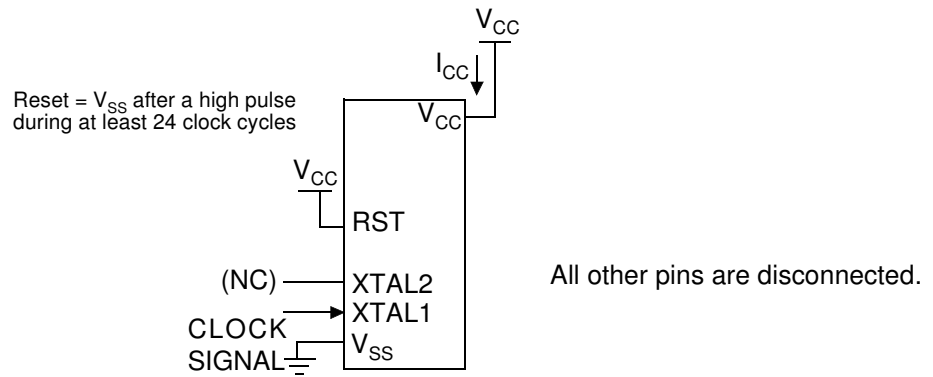
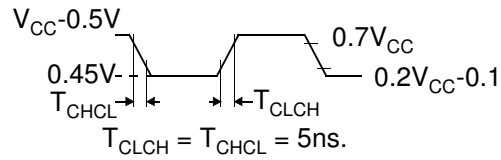

Figure 5. Clock Signal Waveform for I_{CC} Tests in Active and Idle Modes





DC Parameters for A/D Converter

$T_A = 0^\circ\text{C}$ to $+70^\circ\text{C}$; $V_{SS} = 0\text{V}$; $V_{CC} = 2.7\text{V}$ to 5.5V .
 $T_A = -40^\circ\text{C}$ to $+85^\circ\text{C}$; $V_{SS} = 0\text{V}$; $V_{CC} = 2.7\text{V}$ to 5.5V .

Table 3. DC Parameters

Symbol	Parameter	Min	Typ	Max	Unit	Test Conditions
	Resolution		10		bit	
$A_{V_{IN}}$	Analog input voltage	$V_{SS} - 0.2$		$V_{CC} + 0.2$	V	
R_{REF}	Resistance between V_{REF} and V_{SS}	13	18	24	$k\Omega$	
C_{ai}	Analog input Capacitance		60		pF	During sampling
	Integral non-linearity		1	2	lsb	$0.9 V_{CC} < V_{REF} < V_{CC}$
	Differential non-linearity		0.5	1	lsb	$0.9 V_{CC} < V_{REF} < V_{CC}$
	Offset error	-2		2	lsb	$0.9 V_{CC} < V_{REF} < V_{CC}$
	Input source impedance			1	$k\Omega$	For 10-bit resolution at maximum speed

AC Parameters

Explanation of the AC Symbols

Each timing symbol has 5 characters. The first character is always a “t” (that stands for Time). The other characters, depending on their positions, stand for the name of a signal or the logical status of that signal. The following is a list of all the characters and what they stand for.

Example: T_{XHDV} = Time from clock rising edge to input data valid.

$T_A = -40^{\circ}\text{C}$ to $+85^{\circ}\text{C}$ (industrial temperature range); $V_{SS} = 0\text{V}$; $2.7\text{V} < V_{CC} < 5.5\text{V}$; -L range.

Table 61. gives the maximum applicable load capacitance for Port 1, 3 and 4. Timings will be guaranteed if these capacitances are respected. Higher capacitance values can be used, but timings will then be degraded.

Table 4. Load Capacitance Versus Speed Range, in pF

	-L
Port 1, 3 & 4	80

Table 63 gives the description of each AC symbols.

Table 64. gives for each range the AC parameter.

Table 65. gives the frequency derating formula of the AC parameter. To calculate each AC symbols, take the x value corresponding to the speed grade you need (-L) and replace this value in the formula. Values of the frequency must be limited to the corresponding speed grade:

Table 5. Max frequency for Derating Formula Regarding the Speed Grade

	-L X1 Mode, $V_{CC} = 5\text{V}$	-L X2 Mode, $V_{CC} = 5\text{V}$	-L X1 Mode, $V_{CC} = 3\text{V}$	-L X2 Mode, $V_{CC} = 3\text{V}$
Freq (MHz)	40	33	40	20
T (ns)	25	30	25	50

Example:

T_{XHDV} in X2 mode for a -L part at 20 MHz ($T = 1/20^{\text{E6}} = 50 \text{ ns}$):

$$x = 133 \text{ (Table 65)}$$

$$T = 50 \text{ ns}$$

$$T_{XHDV} = 5T - x = 5 \times 50 - 133 = 117 \text{ ns}$$

Serial Port Timing - Shift Register Mode

Table 6. Symbol Description

Symbol	Parameter
T_{XLXL}	Serial port clock cycle time
T_{QVHX}	Output data set-up to clock rising edge
T_{XHGX}	Output data hold after clock rising edge
T_{XHDX}	Input data hold after clock rising edge
T_{XHDV}	Clock rising edge to input data valid

Table 7. AC Parameters for a Fix Clock

Speed	-L ($V_{CC} = 5V$) X2 mode 33 MHz 66 MHz equiv.		-L ($V_{CC} = 5V$) Standard Mode 40 MHz		-L ($V_{CC} = 3V$) X2 Mode 33 MHz 66 MHz equiv.		-L ($V_{CC} = 3V$) Standard Mode 40 MHz		Units
	Min	Max	Min	Max	Min	Max	Min	Max	
T_{XLXL}	180		300		300		300		ns
T_{QVHX}	100		200		200		200		ns
T_{XHGX}	10		30		30		30		ns
T_{XHDX}	0		0		0		0		ns
T_{XHDV}		17		117		17		117	ns

Table 8. AC Parameters for a Variable Clock: Derating Formula

Symbol	Type	Standard Clock	X2 Clock	-L ($V_{CC} = 5V$)	-L ($V_{CC} = 3V$)	Units
T_{XLXL}	Min	12 T	6 T			ns
T_{QVHX}	Min	10 T - x	5 T - x	50	50	ns
T_{XHGX}	Min	2 T - x	T - x	20	20	ns
T_{XHDX}	Min	x	x	0	0	ns
T_{XHDV}	Max	10 T - x	5 T - x	133	133	ns

A/D Converter

Symbol	Parameter	Min	Typ	Max	Units
TConv	Conversion time		11		Clock periods (1 for sampling, 10 for conversion)
TSetup	Setup time	4			μs
FConv_Ck	Clock Conversion frequency			1100 ⁽¹⁾	kHz
	Sampling frequency	10		100	kHz

Notes: 1. For 10 bits resolution

AC Testing Input/Output Waveforms

Figure 8. AC Testing Input/Output Waveforms

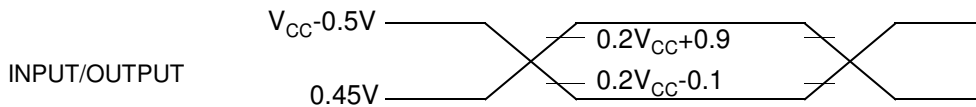

AC inputs during testing are driven at $V_{CC} - 0.5$ for a logic "1" and $0.45V$ for a logic "0". Timing measurement are made at V_{IH} min for a logic "1" and V_{IL} max for a logic "0".

Figure 9. Float Waveforms

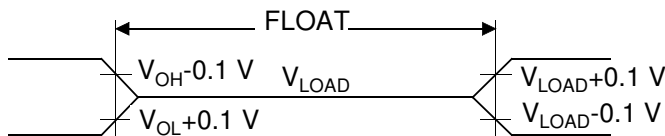

For timing purposes as port pin is no longer floating when a 100 mV change from load voltage occurs and begins to float when a 100 mV change from the loaded V_{OH}/V_{OL} level occurs. $I_{OL}/I_{OH} \geq \pm 20\text{mA}$.

Clock Waveforms

Valid in normal clock mode. In X2 mode XTAL2 signal must be changed to XTAL2 divided by two.

Figure 10. Clock Waveforms

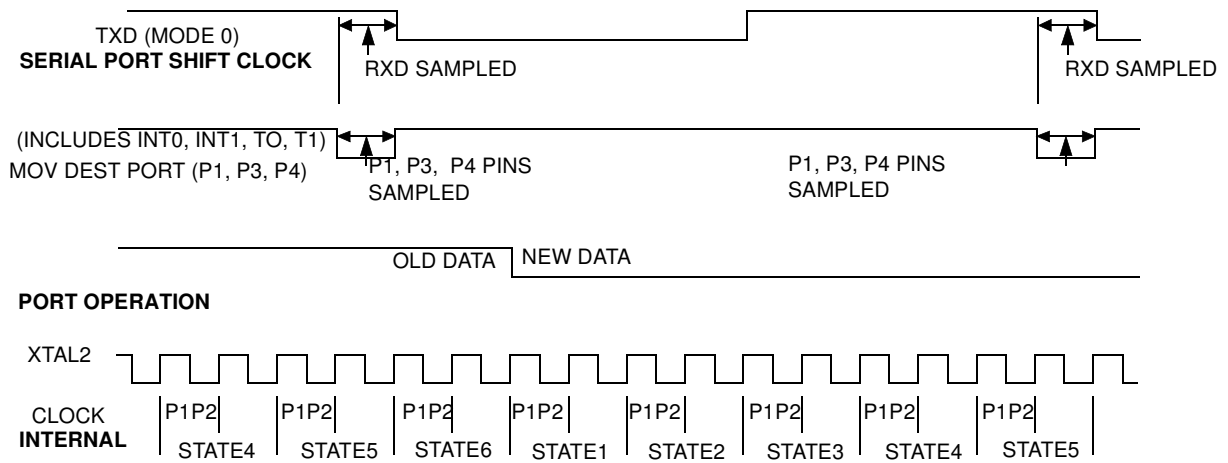

Figure 39 indicates when signals are clocked internally. The time it takes the signals to propagate to the pins, however, ranges from 25 to 125 ns. This propagation delay is dependent on variables such as temperature and pin loading. Propagation also varies from output to output and component. Typically though ($T_A = 25^\circ\text{C}$ fully loaded) RD and WR propagation delays are approximately 50ns. The other signals are typically 85 ns. Propagation delays are incorporated in the AC specifications.

Ordering Information **Table 1.** Maximum Clock Frequency

Code	-L (Vcc = 5V)	-L (Vcc = 3V)	Unit
Standard Mode, oscillator frequency	40	40	MHz
Standard Mode, internal frequency	40	40	
X2 Mode, oscillator frequency	33	20	MHz
X2 Mode, internal equivalent frequency	66	40	

Table 2. Possible Order Entries

Part Number	Memory Size (Bytes)	Supply Voltage	Temperature Range	Max Frequency (MHz)	Package	Packing
AT87C5111-3ZSIL						
AT87C5111-TDSIL						
AT87C5111-TDRIL						
AT87C5111-ICSIL						
AT87C5111-ICRIL						
AT83C5111-3ZSIL						
AT83C5111-TDSIL						
AT83C5111-TDRIL						
AT83C5111-ICSIL						
AT83C5111-ICRIL						

OBSOLETE

Package Drawings

DIL24

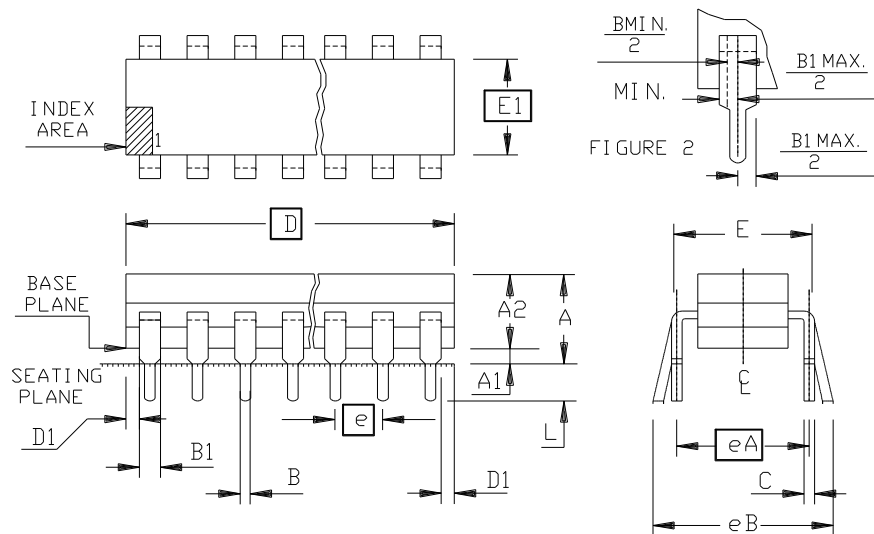

	MM		INCH	
A	-	5.33	-	.210
A1	0.39	-	.015	-
A2	2.92	4.95	.115	.195
B	0.36	-	.014	-
B1	1.14	1.78	.045	.070
C	0.20	0.38	.008	.015
D	28.60	32.30	1.125	1.275
E	7.62	8.25	.300	.325
E1	6.10	7.11	.240	.280
e	2.54	B. S. C	.100	B. S. C
eA	7.62	B. S. C	.300	B. S. C
eB	-	10.92	-	.430
L	2.92	4.06	.115	.160
D1	0.13	-	.005	-
PKG STD	02			

SSOP24

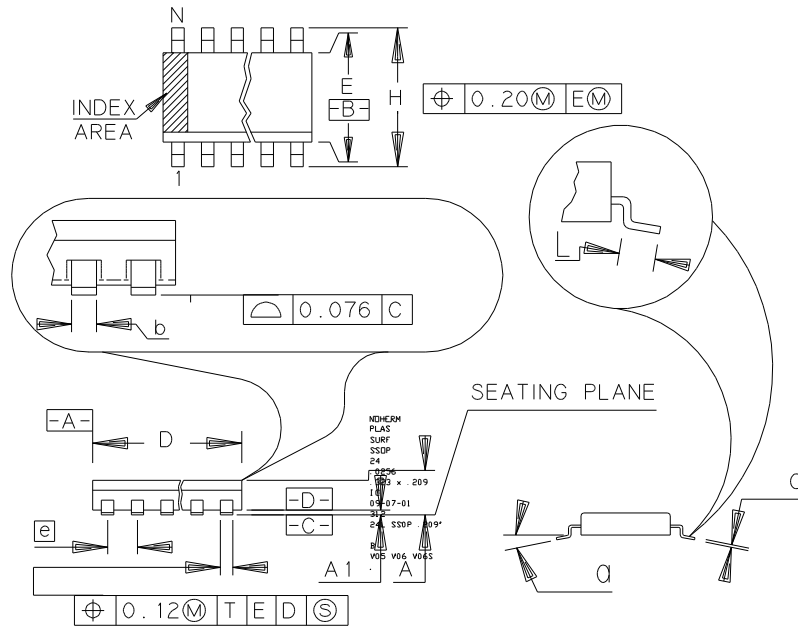

	MM		INCH	
	A	1.73	1.99	.068
A1	0.05	0.21	.002	.008
b	0.25	0.38	.010	.015
C	0.09	0.20	.004	.008
D	8.07	8.33	.318	.328
E	5.20	5.38	.205	.212
e	0.65	BSC	.0256	BSC
H	7.65	7.90	.301	.311
L	0.63	0.95	.025	.037
N	24		24	
a	0°	8°	0°	8°



Atmel Headquarters

Corporate Headquarters

2325 Orchard Parkway
San Jose, CA 95131
TEL 1(408) 441-0311
FAX 1(408) 487-2600

Europe

Atmel Sarl
Route des Arsenaux 41
Case Postale 80
CH-1705 Fribourg
Switzerland
TEL (41) 26-426-5555
FAX (41) 26-426-5500

Asia

Room 1219
Chinachem Golden Plaza
77 Mody Road Tsimhatsui
East Kowloon
Hong Kong
TEL (852) 2721-9778
FAX (852) 2722-1369

Japan

9F, Tonetsu Shinkawa Bldg.
1-24-8 Shinkawa
Chuo-ku, Tokyo 104-0033
Japan
TEL (81) 3-3523-3551
FAX (81) 3-3523-7581

Atmel Operations

Memory

2325 Orchard Parkway
San Jose, CA 95131
TEL 1(408) 441-0311
FAX 1(408) 436-4314

Microcontrollers

2325 Orchard Parkway
San Jose, CA 95131
TEL 1(408) 441-0311
FAX 1(408) 436-4314

La Chantrerie
BP 70602
44306 Nantes Cedex 3, France
TEL (33) 2-40-18-18-18
FAX (33) 2-40-18-19-60

ASIC/ASSP/Smart Cards

Zone Industrielle
13106 Rousset Cedex, France
TEL (33) 4-42-53-60-00
FAX (33) 4-42-53-60-01

1150 East Cheyenne Mtn. Blvd.
Colorado Springs, CO 80906
TEL 1(719) 576-3300
FAX 1(719) 540-1759

Scottish Enterprise Technology Park
Maxwell Building
East Kilbride G75 0QR, Scotland
TEL (44) 1355-803-000
FAX (44) 1355-242-743

RF/Automotive

Theresienstrasse 2
Postfach 3535
74025 Heilbronn, Germany
TEL (49) 71-31-67-0
FAX (49) 71-31-67-2340

1150 East Cheyenne Mtn. Blvd.
Colorado Springs, CO 80906
TEL 1(719) 576-3300
FAX 1(719) 540-1759

Biometrics/Imaging/Hi-Rel MPU/ High Speed Converters/RF Data- com

Avenue de Rochepleine
BP 123
38521 Saint-Egreve Cedex, France
TEL (33) 4-76-58-30-00
FAX (33) 4-76-58-34-80

e-mail

literature@atmel.com

Web Site

<http://www.atmel.com>

© Atmel Corporation 2008.

Atmel Corporation makes no warranty for the use of its products, other than those expressly contained in the Company's standard warranty which is detailed in Atmel's Terms and Conditions located on the Company's web site. The Company assumes no responsibility for any errors which may appear in this document, reserves the right to change devices or specifications detailed herein at any time without notice, and does not make any commitment to update the information contained herein. No licenses to patents or other intellectual property of Atmel are granted by the Company in connection with the sale of Atmel products, expressly or by implication. Atmel's products are not authorized for use as critical components in life support devices or systems.

ATMEL® is a registered trademark of Atmel.

Other terms and product names may be the trademarks of others.



Printed on recycled paper.