

CAD DRAWING - NO MANUAL REVISIONS

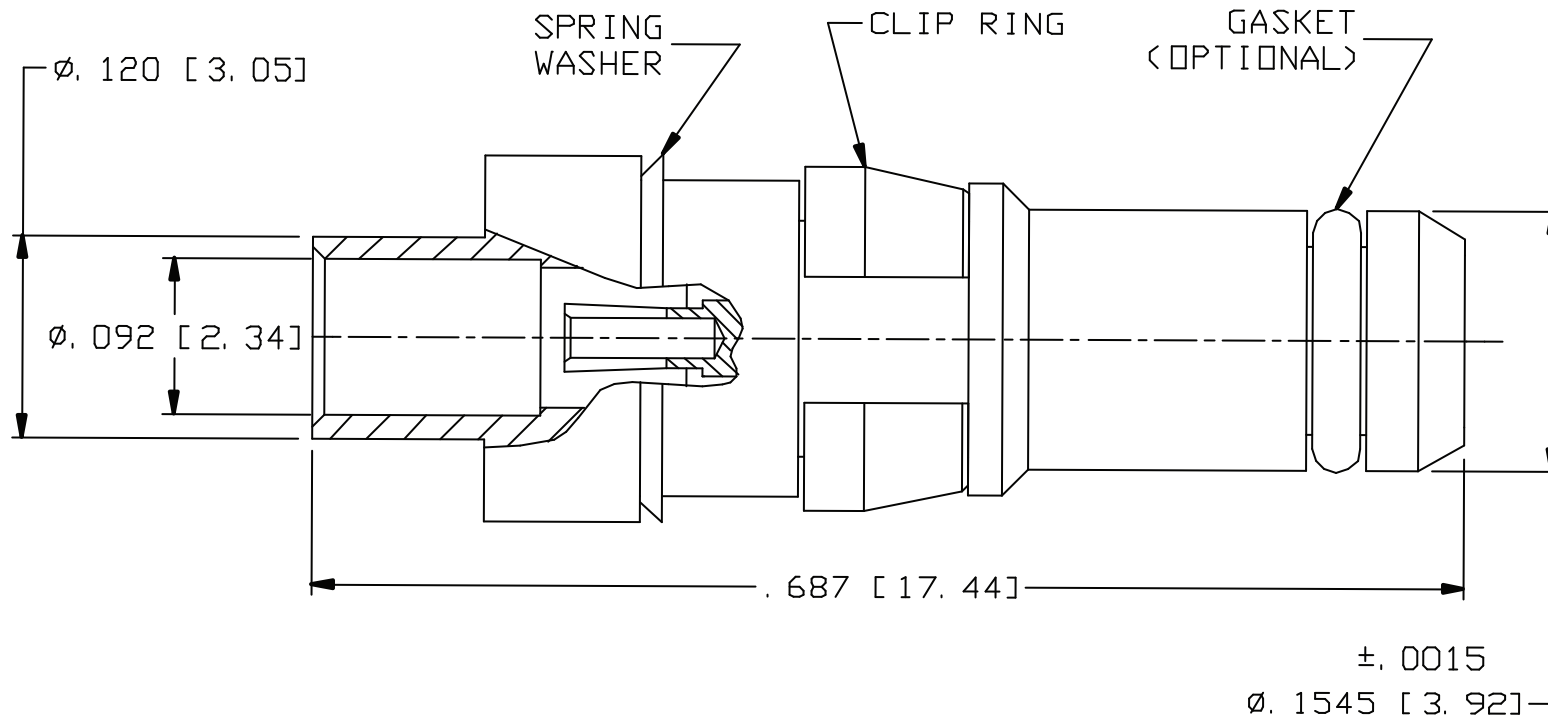

Notes:

26-0020-0860A

- 1) Design and Interface per IDS 26.
- 2) Blindmate RF/Microwave Contact for Standard Density Multiport RF D-Subminiature Connectors.
- 3) Size 8 PkZ®, 50 Ohm, 32 GHz Straight Plug, Without Gasket.
- 4) Direct Solder to RG-405 Cable (M17/133) .086 S.R.
- 5) .000050" Min. Gold Over Nickel.

K	PER ECN 10538	08/18/10	JEM	PALCO CONNECTOR 22 GREAT HILL RD., NAUGATUCK, CT 06770 UNLESS OTHERWISE SPECIFIED, PALCO WORKMANSHIP STANDARDS APPLY TOLERANCES ON: DECIMALS: XX ± .01 .XXX ± .005 ANGLES ±1/2° 32' DIMENSIONS IN INCHES OR (METRIC) DO NOT SCALE PRINTS CATALOG ITEM	DRAWN EK	CHECKED JEM	ENGINEER HN	APPROVED JEM	FSCM 58167
H	PER ECN 10442	06/30/10	JEM			DESCRIPTION PKZ, PLUG, SOLDER			
G	PER ECN 10224	03/09/10	JEM			DATE 03/19/96	DRAWING NO. 26-0020-0860	PLATING OPT. A, B	
F	PER ECN 9912	05/06/09	JEM						
E	PER ECN 9633	11/18/08	JEM						
REV.	DESCRIPTION	DATE	APPR.						

THE INFORMATION IN THIS DOCUMENT IS CONFIDENTIAL AND PROPRIETARY AND MAY NOT BE USED FOR ANY PURPOSE WITHOUT THE WRITTEN CONSENT OF PALCO.

CABLE ASSEMBLY PROCEDURE		PALEO CONNECTOR 22 GREAT HILL ROAD, NAUGATUCK, CT. 06770 PHONE: (203) 729-9090 FAX: (203) 723-1794	REV	DESCRIPTION	DATE	APPR
P/N 26-002X-0860			F	PER ECN 9912	05/06/09	JEM
PAGE 1 OF 2	DATE: 03/20/96		G	PER ECN 10224	03/09/10	JEM
DRAWN: EK	APPROVED: JEM		H	PER ECN 10442	06/30/10	JEM
FOR USE WITH RG-405 CABLE		K	PER ECN 10538	08/18/10	JEM	

FOR USE WITH RG-405

STEP 1

TRIM CABLE TO DIMENSIONS SHOWN.
POINT END AS SHOWN.

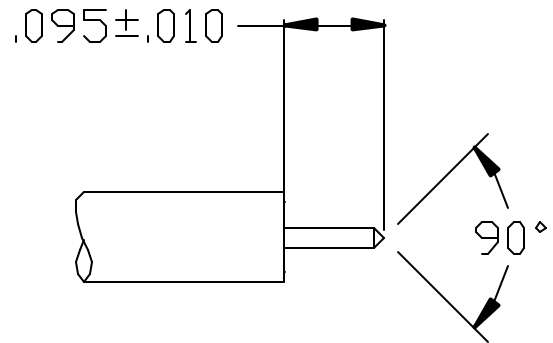

STEP 2

INSERT CABLE INTO BODY AND SOLDER AS SHOWN. CLEAN SOLDER JOINT.

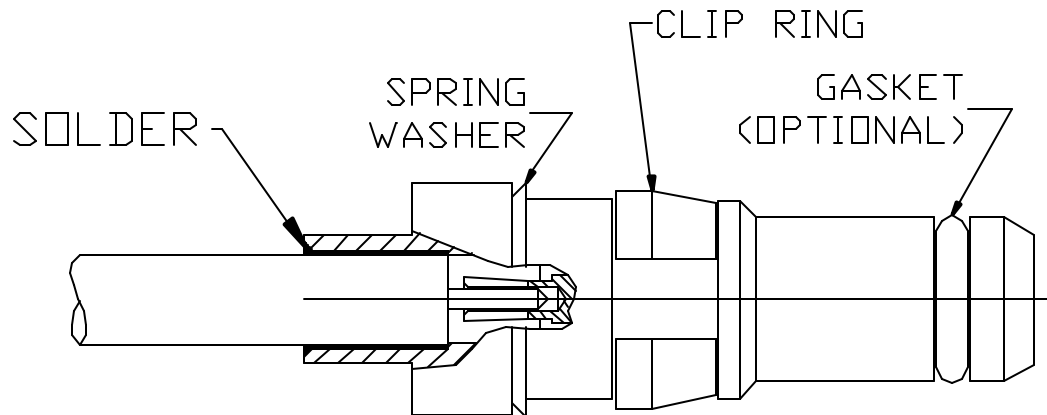

CABLE ASSEMBLY PROCEDURE	
P/N	26-002X-0860
PAGE 2 OF 2	DATE: 03/20/96
DRAWN: EK	APPROVED: JEM
FOR USE WITH TFLEX-405 CABLE	

PALEO
CONNECTOR

22 GREAT HILL ROAD, NAUGATUCK, CT. 06770
PHONE: (203) 729-9090 FAX: (203) 723-1794

REV	DESCRIPTION	DATE	APPR
F	PER ECN 9912	05/06/09	JEM
G	PER ECN 10224	03/09/10	JEM
H	PER ECN 10442	06/30/10	JEM
K	PER ECN 10538	08/18/10	JEM

FOR USE WITH TFLEX-405

STEP 1
TIN DIP CABLE TO
DIMENSIONS SHOWN.

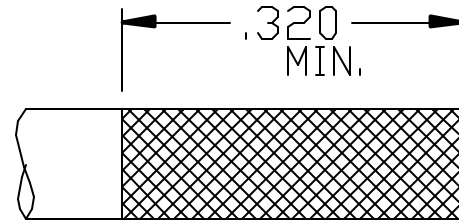

STEP 2
TRIM CABLE TO DIMENSIONS
SHOWN AND POINT
CENTER CONDUCTOR.

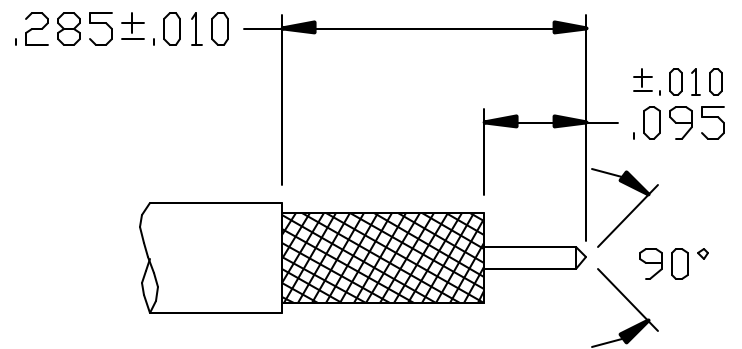

STEP 3
INSERT CABLE INTO BODY AND SOLDER
AS SHOWN. CLEAN SOLDER JOINT.

