

# DATA SHEET

## (Tentative)

Part No.	AN32181A
Package Code No.	XLGA028-W-2326AKL

Contents

- Overview ..... 3
- Features ..... 3
- Applications ..... 3
- Package ..... 3
- Type ..... 3
- System Image ..... 3
- Application Circuit Example (Block Diagram) ..... 4
- Absolute Maximum Ratings ..... 5
- Operating Supply Voltage Range ..... 5
- Allowable Voltage Range ..... 6
- Electrical Characteristics ..... 7
- Usage Notes ..... 11

# AN32181A (Tentative)

## 144 Dots Matrix LED driver IC

### ■ Overview

AN32181B is a 144 dots Matrix LED driver. It can drive up to 48 RGB LEDs.

### ■ Feature

- LED 12 × 12 matrix driver (Total LED that can be driven = 144)
- LED Selectable Maximum Current
- LED Melody Mode function
- LED Open/Short Detection
- LED Ghost Image Prevention Function
- SPI Interface (4 Slave address selectable)
- I<sup>2</sup>C interface (Standard Mode, Fast Mode and Fast Mode Plus) (4 Slave address selectable)

### ■ Applications

- LED driver IC

### ■ Package

- 28 pin Fine Pitch Land Grid Array Package (LGA Type)

### ■ Type

- Bi-CMOS IC

### ■ System image

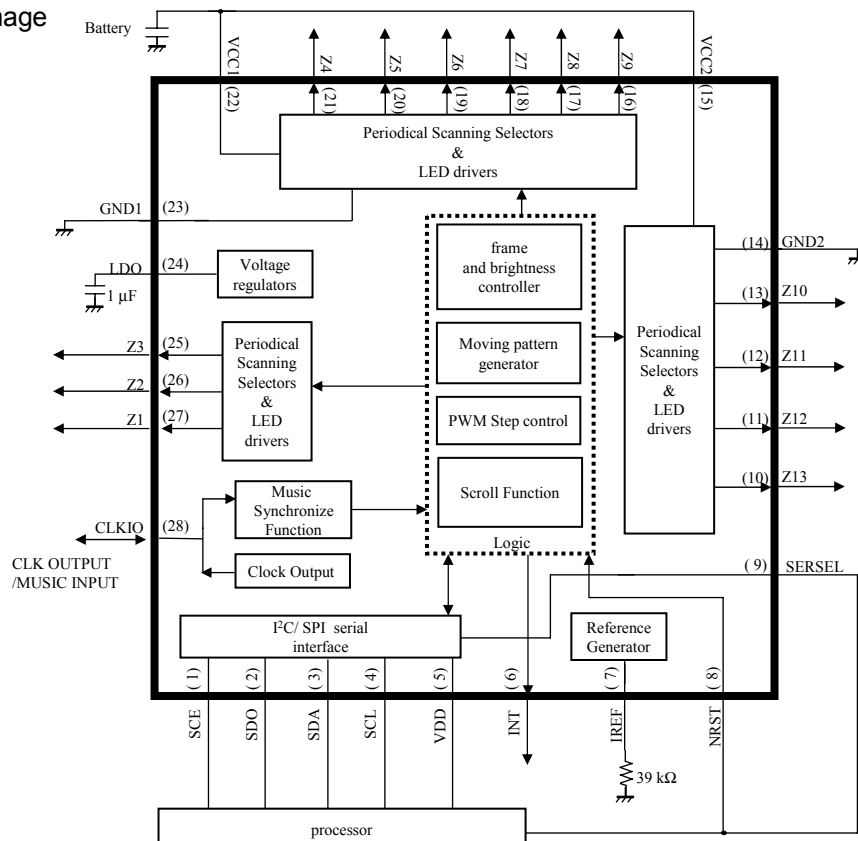

### ■ Application Circuit Example (Block Diagram)

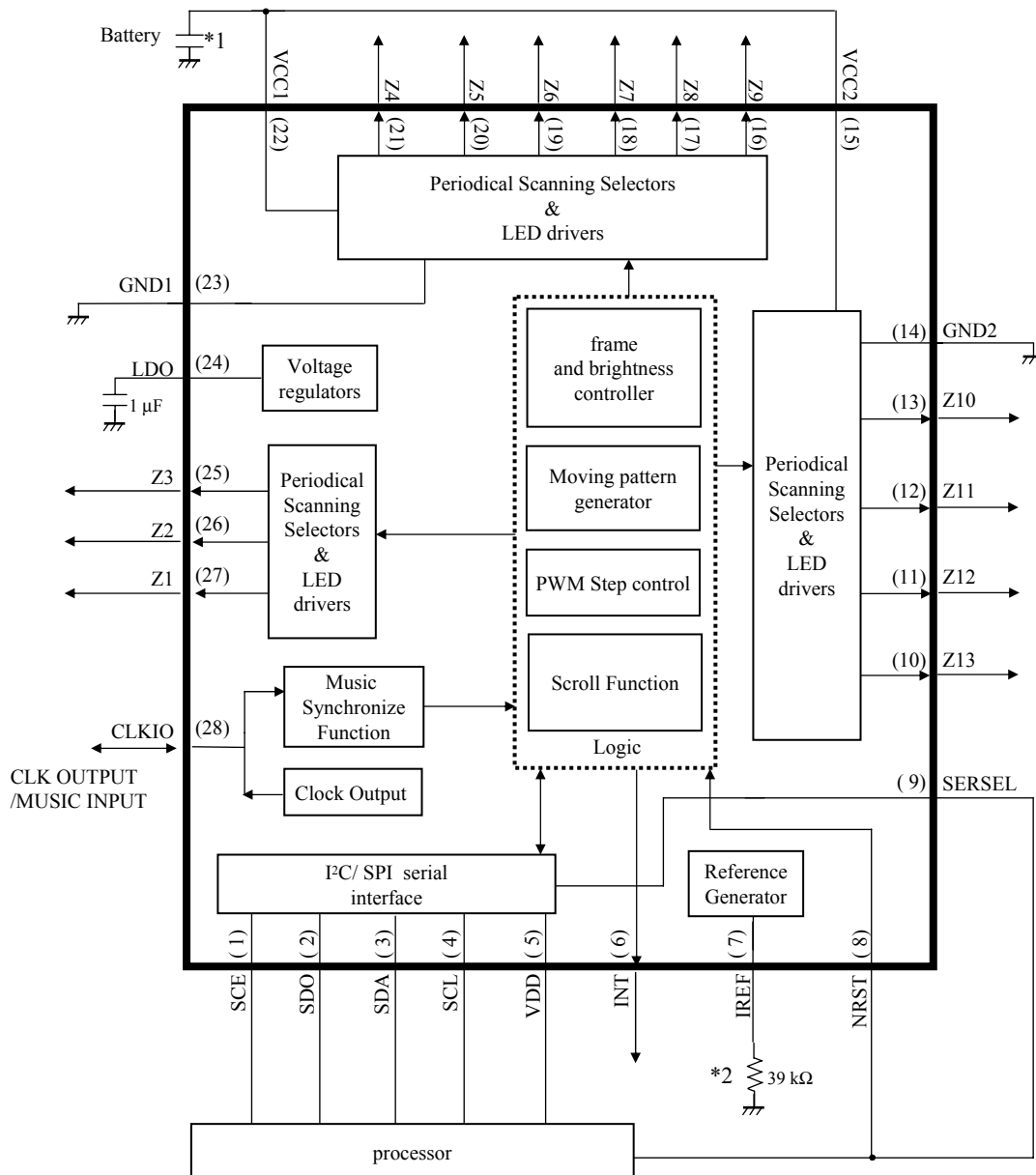

- Notes
- This application circuit is an example. The operation of mass production set is not guaranteed. You should perform enough evaluation and verification on the design of mass production set. You are fully responsible for the incorporation of the above application circuit and information in the design of your equipment.
  - This block diagram is for explaining functions. Part of the block diagram may be omitted, or it may be simplified.
- \*1 : VCC capacitor is for noise cancellation. Please select an appropriate value according to PCB pattern etc.
- \*2 : To ensure the accuracy of the constant current of each LED, it is recommended to use Panasonic Resistor ERJ2RHD393X ( $\pm 0.5\%$  tolerance). To ensure the accuracy of the constant current of each LED, place the resistor as close as possible to IC and parasitic capacitor of not more than 20 pF at IREF pin.

### ■ Absolute Maximum Ratings

Note) Absolute maximum ratings are limit values which do not result in damages to this IC, and IC operation is not guaranteed at these limit values.

A* No.	Parameter	Symbol	Range	Units	Note
1	Power Supply Voltage	VCC	6.0	V	*1
		VDD	6.0	V	*1
2	Power Supply Current	I <sub>CC</sub>	—	A	—
3	Power Dissipation	P <sub>D</sub>	112	mW	*2
4	Operating Ambient Temperature	T <sub>opr</sub>	−30 to +85	°C	*3
5	Storage Temperature	T <sub>stg</sub>	−55 to +125	°C	*3

Notes) \*: A is a number for internal management of this page of Panasonic.

\*1: The value where the absolute maximum ratings and power dissipation should not exceed is indicated.

\*2: The power dissipation shown is the value at T<sub>a</sub> = 85°C for the independent IC package without a heat sink. When using this IC, refer to P<sub>D</sub> – T<sub>a</sub> diagram in the ■ Technical Data and design the heat radiation with sufficient margin so that the allowable value might not be exceeded based on the conditions of power supply voltage, load, and ambient temperature.

\*3: Except for the power dissipation, operating ambient temperature, and storage temperature, all ratings are for T<sub>a</sub> = 25°C.

### ■ Operating Supply Voltage Range

Parameter	Symbol	Range	Unit	Note
Power Supply Voltage Range	VCC	3.1 to 5.5	V	*1
	VDD	1.7 to 5.5	V	*1

Note) Maximum Operating Supply Voltages for VCC and VDD (VCC<sub>max</sub> and VDD<sub>max</sub>) are 5.5 V.

\*1 : The values under the condition not exceeding the above absolute maximum ratings and the power dissipation.

### ■ Allowable Voltage Range

- Notes)
- Allowable current and voltage ranges are limit ranges which do not result in damages to this IC, and IC operation is not guaranteed within these limit ranges.
  - Voltage values, unless otherwise specified, are with respect to GND.  
GND is voltage for GND1, GND2. GND1 = GND2
  - Do not apply external currents or voltages to any pin not specifically mentioned.
  - When LED output Z terminals are applied by external voltage sources, it is advisable that the absolute maximum voltage applied to LED output terminal is not more than 6V in order to prevent any damage in IC.

QFN Pin No.	Terminal	Rating	Unit	Remark
1	SCE	- 0.5 to 6.0	V	—
3	SDA	- 0.5 to 6.0	V	*1
4	SCL	- 0.5 to 6.0	V	—
8	NRST	- 0.3 to 6.0	V	—
9	SERSEL	- 0.3 to 6.0	V	—
28	CLKIO	- 0.3 to 6.0	V	*1

- Note) \*1: This value is absolute maximum voltage when these terminals are used as input.  
External Voltage and current are prohibited when these terminals are used as output.

### ■ Electrical Characteristics at VCC = 3.6 V, VDD = 1.85 V

Notes) Operating Ambient Temperature, T<sub>a</sub> = 25°C±2°C, unless specifically mentioned

B No.	Items	Symbol	Conditions	Limits			Unit	Note
				Min	Typ	Max		
Circuit Current								
1	Circuit Current (1) OFF Mode	ICC1	NRST = 0 V ICC1 = IP15 + IP22 + IP5	—	0	1	μA	—
2	Circuit Current (2) OFF Mode	ICC2	NRST = High ICC2 = IP15 + IP22 + IP5	—	240	500	μA	—
Internal Oscillator								
3	Oscillation Frequency	FDC1	VCC = 3.6 V	1.92	2.40	2.88	MHz	—
SCAN Switch								
4	Switch On Resistance	RSCAN	VCC = 3.6 V IP10, 11, 12, 13, 16, 17, 18, 19, 20, 21, 25, 26, 27 = -20 mA	—	1	2.5	Ω	—
Constant Voltage Source (LDO)								
5	Output voltage (1)	VL1	IP24 = -10 μA VL1 = VP24	2.75	2.85	2.95	V	—
6	Output voltage (2)	VL2	IP24 = -15 mA VL2 = VP24	2.75	2.85	2.95	V	—
CLKIO								
7	High Level Input Voltage Range	VIH1	High Level Acknowledged Voltage (At External CLK Input Mode)	0.7 × VDD	—	VDD + 0.3	V	—
8	Low Level Input Voltage Range	VIL1	Low Level Acknowledged Voltage (At External CLK Input Mode)	-0.3	—	0.3 × VDD	V	—
9	High Level Output Voltage	VOH1	IP28_2 = -1mA (At Internal CLK Output Mode)	0.8 × VDD	—	VDD + 0.3	V	—
10	Low Level Output Voltage	VOL1	IP28_2 = +1mA (At Internal CLK Output Mode)	-0.3	—	0.2 × VDD	V	—
11	High Level input Current	IIH1	VCC = 5.5 V VP28 = 5.5 V IIH1 = IP28	-1	0	1	μA	—
12	Low Level input Current	IIL1	VCC = 5.5 V VP28 = 0 V IIL1 = IP28	-1	0	1	μA	—

■ Electrical Characteristics (continued) at VCC = 3.6 V, VDD = 1.85 V

Notes) Operating Ambient Temperature, T<sub>a</sub> = 25°C±2°C, unless specifically mentioned

B No.	Item	Symbol	Conditions	Limits			Unit	Note
				Min	Typ	Max		
Constant Current Source (Matrix LED)								
13	Output Current (1)	IMX1	LED Current Setting = 19.85 mA IMAX = [01010] VP10, 11, 12, 13, 16, 17, 18, 19, 20, 21, 25, 26, 27 = 1 V IMX1 = IP10, 11, 12, 13, 16, 17, 18, 19, 20, 21, 25, 26, 27	18.85	19.85	20.85	mA	*1
14	IMAX Current Step	IMXSTEP	Constant Current Mode LED current setting = 22 mA, IMAX = [01011] VP10, 11, 12, 13, 16, 17, 18, 19, 20, 21, 25, 26, 27 = 1 V ILED1 = IP10, 11, 12, 13, 16, 17, 18, 19, 20, 21, 25, 26, 27 LED current setting = 19.85 mA, IMAX = [01010] VP10, 11, 12, 13, 16, 17, 18, 19, 20, 21, 25, 26, 27 = 1 V ILED2 = IP10, 11, 12, 13, 16, 17, 18, 19, 20, 21, 25, 26, 27 IMXSTEP = ILED1 – ILED2	0	2	3.5	mA	—
15	OFF Mode Leak Current1	IMXOFF1	VCC = 5.5 V, VDD = 5.5 V OFF Mode VP10, 11, 12, 13, 16, 17, 18, 19, 20, 21, 25, 26, 27 = 5.5 V IMXOFF1 = 10, 11, 12, 13, 16, 17, 18, 19, 20, 21, 25, 26, 27	-1	—	1	μA	—
16	OFF Mode Leak Current2	IMXOFF2	VCC = 5.5 V, VDD = 5.5 V OFF Mode VP10, 11, 12, 13, 16, 17, 18, 19, 20, 21, 25, 26, 27 = 0 V IMXOFF2 = 10, 11, 12, 13, 16, 17, 18, 19, 20, 21, 25, 26, 27	-1	—	1	μA	—
17	Channel Difference	IMXCH	LED Current Setting = 19.85 mA IMAX = [01010] Difference of Z1 to 13 current from the average current value	-5	—	5	%	—
Voltage at which LED driver can keep constant current value								
18	LED Driver voltage	VLD2	LED Current Setting = 19.85 mA IMAX = [01010] Voltage at which LED Current change within ±5% compared with LED Current of pin voltage = 0.5 V.	0.4	—	—	V	—

Note) \*1 : This is allowable value when recommended parts (ERJ2RHD393X) are used for the terminal IREF.

■ Electrical Characteristics (continued) at VCC = 3.6 V, VDD = 1.85 V

Notes) Operating Ambient Temperature, T<sub>a</sub> = 25°C±2°C, unless specifically mentioned

B No.	Item	Symbol	Conditions	Limits			Unit	Note
				Min	Typ	Max		
<b>SERSEL</b>								
19	High Level Input Voltage Range	VIH2	High Level Acknowledged Voltage	0.7 × VCC	—	VCC + 0.3	V	—
20	Low Level Input Voltage Range	VIL2	Low Level Acknowledged Voltage	-0.3	—	0.3 × VCC	V	—
21	High Level Input Current	IIH2	VCC = VDD = 5.5 V VP9 = 5.5 V IIH2 = IP9	-1	0	1	μA	—
22	Low Level Input Current	IIL2	VCC = VDD = 5.5 V VP9 = 0 V IIL2 = IP9	-1	0	1	μA	—
<b>NRST</b>								
23	High Level Input Voltage Range	VIH3	High Level Acknowledged Voltage	1.5	—	VCC + 0.3	V	—
24	Low Level Input Voltage Range	VIL3	Low Level Acknowledged Voltage	-0.3	—	0.6	V	—
25	High Level Input Current	IIH3	VCC = VDD = 5.5 V VP8 = 5.5 V IIH3 = IP8	-1	0	1	μA	—
26	Low Level Input Current	IIL3	VCC = VDD = 5.5 V VP8 = 0 V IIL3 = IP8	-1	0	1	μA	—
<b>INT</b>								
27	ON Resistance	RINTON	IP6 = 5 mA	—	10	50	Ω	—
<b>SDO</b>								
28	High Level Output Voltage	VOH3	IP2 = -3 mA	0.7 × VDD	—	VDD + 0.3	V	—
29	Low Level Output Voltage	VOL3	IP2 = 3 mA	0	—	0.3 × VDD	V	—
<b>SCE</b>								
30	High-level input voltage range	VIH4	High Level Acknowledged Voltage	VDD × 0.7	—	VDD + 0.5	V	—
31	Low-level input voltage range	VIL4	Low Level Acknowledged Voltage	-0.5	—	VDD × 0.3	V	—
32	High-level input current	IIH4	VCC = VDD = 5.5 V VP1 = 5.5 V IIH4 = IP1	-1	0	1	μA	—
33	Low-level input current	IIL4	VCC = VDD = 5.5 V VP1 = 0 V IIH4 = IP1	-1	0	1	μA	—

■ Electrical Characteristics (continued) at VCC = 3.6 V, VDD = 1.85 V

Notes) Operating Ambient Temperature,  $T_a = 25^{\circ}\text{C} \pm 2^{\circ}\text{C}$ , unless specifically mentioned

B No.	Item	Symbol	Conditions	Limits			Unit	Note
				Min	Typ	Max		
I <sup>2</sup> C bus (Internal I/O stage characteristics) (SCL, SDA)								
34	Low-level input voltage	$V_{IL}$	Voltage which recognized that SDA and SCL are Low-level	-0.5	—	$0.3 \times V_{DD}$	V	*2
35	High-level input voltage	$V_{IH}$	Voltage which recognized that SDA and SCL are High-level	$0.7 \times V_{DD}$	—	$V_{DD_{max}} + 0.5$	V	*2
36	Low-level output voltage 1	$V_{OL1}$	VDD > 2 V IP3_2(sink current) = 3 mA	0	—	0.4	V	—
37	Low-level output voltage 2	$V_{OL2}$	VDD < 2 V IP3_2(sink current) = 3 mA	0	—	$0.2 \times V_{DD}$	V	—
38	Low-level output current	$I_{OL}$	$V_{OL} = 0.4 \text{ V}$	20	—	—	mA	—
39	Input current each I/O pin	$I_i$	VCC = 5.5 V, VDD = 5.5 V VP3, 4 = $0.1V_{DD_{max}}$ to $0.9V_{DD_{max}}$	-10	0	10	$\mu\text{A}$	—
40	SCL clock frequency	$f_{SCL}$	—	0	—	1 000	kHz	—

Note)  $V_{DD_{max}}$  refers to the maximum operating supply voltage of VDD.

\*2 : The input threshold voltage of I<sup>2</sup>C bus ( $V_{th}$ ) is linked to VDD (I<sup>2</sup>C bus I/O stage supply voltage).

In case the pull-up voltage is not VDD, the threshold voltage ( $V_{th}$ ) is fixed to  $((V_{DD} / 2) \pm (\text{Schmitt width}) / 2)$  and High-level, Low-level of input voltage are not specified.

In this case, pay attention to Low-level (max.) value ( $V_{IL_{max}}$ ).

It is recommended that the pull-up voltage of I<sup>2</sup>C bus is set to the I<sup>2</sup>C bus I/O stage supply voltage (VDD).

**■ Usage Notes****• Special attention and precaution in using**

1. This IC is intended to be used for general electronic equipment [Mobile phones].

Consult our sales staff in advance for information on the following applications:

- Special applications in which exceptional quality and reliability are required, or if the failure or malfunction of this IC may directly jeopardize life or harm the human body.
- Any applications other than the standard applications intended.
  - (1) Space appliance (such as artificial satellite, and rocket)
  - (2) Traffic control equipment (such as for automobile, airplane, train, and ship)
  - (3) Medical equipment for life support
  - (4) Submarine transponder
  - (5) Control equipment for power plant
  - (6) Disaster prevention and security device
  - (7) Weapon
  - (8) Others : Applications of which reliability equivalent to (1) to (7) is required

It is to be understood that our company shall not be held responsible for any damage incurred as a result of or in connection with your using the IC described in this book for any special application, unless our company agrees to your using the IC in this book for any special application.

2. Pay attention to the direction of LSI. When mounting it in the wrong direction onto the PCB (printed-circuit-board), it might smoke or ignite.
3. Pay attention in the PCB (printed-circuit-board) pattern layout in order to prevent damage due to short circuit between pins. In addition, refer to the Pin Description for the pin configuration.
4. Perform a visual inspection on the PCB before applying power, otherwise damage might happen due to problems such as a solder-bridge between the pins of the semiconductor device. Also, perform a full technical verification on the assembly quality, because the same damage possibly can happen due to conductive substances, such as solder ball, that adhere to the LSI during transportation.
5. Take notice in the use of this product that it might break or occasionally smoke when an abnormal state occurs such as output pin- $V_{CC}$  short (Power supply fault), output pin-GND short (Ground fault), or output-to-output-pin short (load short) .  
And, safety measures such as an installation of fuses are recommended because the extent of the above-mentioned damage and smoke emission will depend on the current capability of the power supply.
6. When designing your equipment, comply with the range of absolute maximum rating and the guaranteed operating conditions (operating power supply voltage and operating environment etc.). Especially, please be careful not to exceed the range of absolute maximum rating on the transient state, such as power-on, power-off and mode-switching. Otherwise, we will not be liable for any defect which may arise later in your equipment.  
Even when the products are used within the guaranteed values, take into the consideration of incidence of break down and failure mode, possible to occur to semiconductor products. Measures on the systems such as redundant design, arresting the spread of fire or preventing glitch are recommended in order to prevent physical injury, fire, social damages, for example, by using the products.
7. When using the LSI for new models, verify the safety including the long-term reliability for each product.
8. When the application system is designed by using this LSI, be sure to confirm notes in this book.  
Be sure to read the notes to descriptions and the usage notes in the book.

## Request for your special attention and precautions in using the technical information and semiconductors described in this book

- (1) If any of the products or technical information described in this book is to be exported or provided to non-residents, the laws and regulations of the exporting country, especially, those with regard to security export control, must be observed.
- (2) The technical information described in this book is intended only to show the main characteristics and application circuit examples of the products. No license is granted in and to any intellectual property right or other right owned by Panasonic Corporation or any other company. Therefore, no responsibility is assumed by our company as to the infringement upon any such right owned by any other company which may arise as a result of the use of technical information described in this book.
- (3) The products described in this book are intended to be used for general applications (such as office equipment, communications equipment, measuring instruments and household appliances), or for specific applications as expressly stated in this book.  
Consult our sales staff in advance for information on the following applications:
  - Special applications (such as for airplanes, aerospace, automotive equipment, traffic signaling equipment, combustion equipment, life support systems and safety devices) in which exceptional quality and reliability are required, or if the failure or malfunction of the products may directly jeopardize life or harm the human body.It is to be understood that our company shall not be held responsible for any damage incurred as a result of or in connection with your using the products described in this book for any special application, unless our company agrees to your using the products in this book for any special application.
- (4) The products and product specifications described in this book are subject to change without notice for modification and/or improvement. At the final stage of your design, purchasing, or use of the products, therefore, ask for the most up-to-date Product Standards in advance to make sure that the latest specifications satisfy your requirements.
- (5) When designing your equipment, comply with the range of absolute maximum rating and the guaranteed operating conditions (operating power supply voltage and operating environment etc.). Especially, please be careful not to exceed the range of absolute maximum rating on the transient state, such as power-on, power-off and mode-switching. Otherwise, we will not be liable for any defect which may arise later in your equipment.  
Even when the products are used within the guaranteed values, take into the consideration of incidence of break down and failure mode, possible to occur to semiconductor products. Measures on the systems such as redundant design, arresting the spread of fire or preventing glitch are recommended in order to prevent physical injury, fire, social damages, for example, by using the products.
- (6) Comply with the instructions for use in order to prevent breakdown and characteristics change due to external factors (ESD, EOS, thermal stress and mechanical stress) at the time of handling, mounting or at customer's process. When using products for which damp-proof packing is required, satisfy the conditions, such as shelf life and the elapsed time since first opening the packages.
- (7) This book may be not reprinted or reproduced whether wholly or partially, without the prior written permission of our company.