

Z02922

TRANSACTION PROCESSING MODEM DATA PUMP WITH INTEGRATED AFE

FEATURES

Device	Data Pump	AFE	Speed (MHz)
Z02922	16-Bit	Integrated	12.5

- Combined Data Pump and Analog Front-End (AFE)
- Half Duplex Data Modem Throughput to 9600 bps using V.29 Quick Connect
- Full Duplex Data Modem Throughput to 2400 bps
 - ITU V.22bis, V.23, V.22, V.21
 - Bell 212A and Bell 103
- FSK (V.23 1200/75 bps, V.21/Bell 103 300 bps), DPSK (V.22/Bell 212A 1200 bps), or QAM Encoding (V.22bis 2400 bps)
- V.29 Quick Connect handshake performs line turnaround in less than 50 milliseconds
- Automatic handshake plus full manual control over handshake timings
- Scrambler/descrambler Functions plus Selectable Control Over Internal Data Pump Functions
- Programmable Bi-Quad Tone Detectors for Call Progress Tone Detection
- Adaptive Equalization to Compensate for a Wide Variety of Line Conditions
- Programmable Transmit Attenuation and Selectable Receive Threshold
- Fully Programmable Call Progress Detectors, Signal Quality Detectors, Tone Detectors, Tone Generators, and Transmit Signal Levels Aid in Rapid Country Qualifications
- Host Port Allows Direct Parallel Interface to Standard 8Bit Microprocessors
- HDLC Framing at All Speeds
- On-Chip Peripherals
 - Full-Duplex Voice Band AFE with 12-Bit Resolution
 - V.24 Compatible Serial Interface Port
 - Eye Pattern Interface
- Low Power Consumption: 50 mA Typical
- 44-Pin PLCC Package
- Single +5 VDC Power Supply
- 0°C to +70°C Commercial Temperature Range and -40°C to +85°C Extended Temperature Range

Note: (1) International Telecommunications Union (ITU), formerly CCITT.

GENERAL DESCRIPTION

The Z02922 TransPro™ modem is a synchronous single-chip modem that provides a means to construct a V.22bis modem capable of 2400 bps full duplex, or 9600 bps half duplex, over dial-up lines. This device is specifically designed for use in embedded modem applications where space, performance, and low power consumption are key requirements.

The Z02922 TransPro™ includes a Quick Connect handshake option that allows the user to make handshakes in 50 milliseconds or less. This feature is especially useful in transaction processing applications such as credit card terminals and network access controllers where a small amount of data is transmitted.

GENERAL DESCRIPTION (Continued)

Operating over the Public Switched Telephone Network (PSTN), the Z02922 meets the modem standards for V.22bis, V.22, V.23, V.21, Bell 212A, and Bell 103.

A typical modem can be made by simply adding a control microprocessor (host), phone line interface, and DTE interface.

The Z02922 TransPro™ performs HDLC framing at all speeds. This capability eliminates the need for an external Serial Input/Output (SIO) device in Data Terminal Equipment (DTE) for products incorporating error control.

All modulation, demodulation, filtering, A/D and D/A conversion functions for transmit and receive are provided on-chip. Automatic and selectable compromise equalizers are included to optimize performance over a wide range of line types.

The Z02922 device compensates for a wide variety of adverse line conditions by using a combination of fixed link, fixed cable, and adaptive equalizers.

The Z02922 provides comprehensive selectable and programmable tone generation and detection.

All digital I/O signals are TTL compatible. The parallel interface is compatible with standard 8-bit microprocessors, allowing direct access to eight I/O registers and indirect access to the modem RAM.

The RAM access capability allows the host to retrieve diagnostic data, modem/line status and control data and set

programmable coefficients. The serial interface is used for data transfer and is compatible with V.24 specifications. All control and status information is transferred by means of the parallel interface.

The Z02922 transmit drivers and receive amplifiers can be connected directly to a Data Access Arrangement (DAA) by means of a transformer, thereby reducing the external circuits to a minimum.

In addition, the Z02922 provides for further system level savings by providing built-in filters for both the Transmitter Analog Output and the Receiver Analog Input, thus eliminating the need for external filtering components.

The Z02922 device operates on a single +5 VDC power supply. During periods of no traffic, the host can place the modem into Sleep mode, reducing power consumption to less than 1 percent of full load power.

Notes: All signals with an overline, “ $\overline{}$ ”, are active Low. For example, $\overline{B/W}$ (WORD is active Low); \overline{B}/W (BYTE is active Low, only).

Power connections follow conventional descriptions below:

Connection	Circuit	Device
Power	V_{CC}	V_{DD}
Ground	GND	V_{SS}

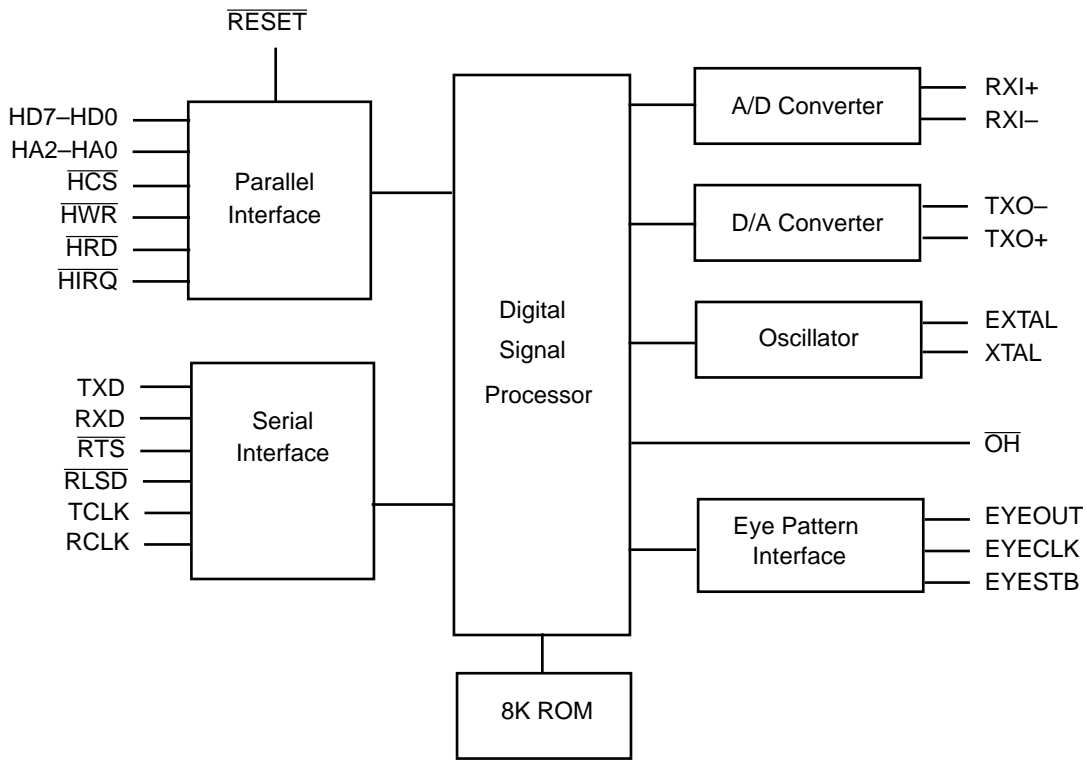

Figure 1. Z02922 Block Diagram

USER INFORMATION

The Zilog Z02922 TransPro™ data pump can be selected for either parallel or serial synchronous data transfer under software control. Figure 1 shows a block diagram of the general modem chip interface. The hardware and software configurations can be customized for a particular modem application. The parallel interface allows direct access to 7 I/O registers, indirect access to the modem RAM, and is compatible with most 8-bit microprocessors, including the

Z8, Z80, and Z18X family devices. The serial interface is used for data transfer and is compatible with V.24. Controls and status information are transferred via the parallel interface. The RAM access capability allows indirect access to diagnostic data, additional status control, and programmable coefficients. The hardware and software interfaces are presented in the subsequent sections.

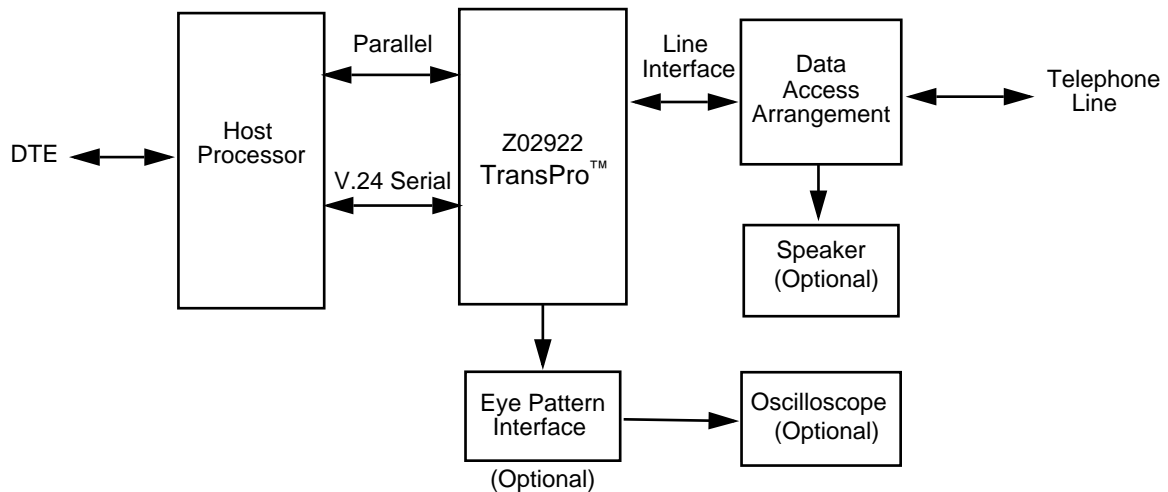

Figure 2. Z02922 System Block Diagram

PIN DESCRIPTION

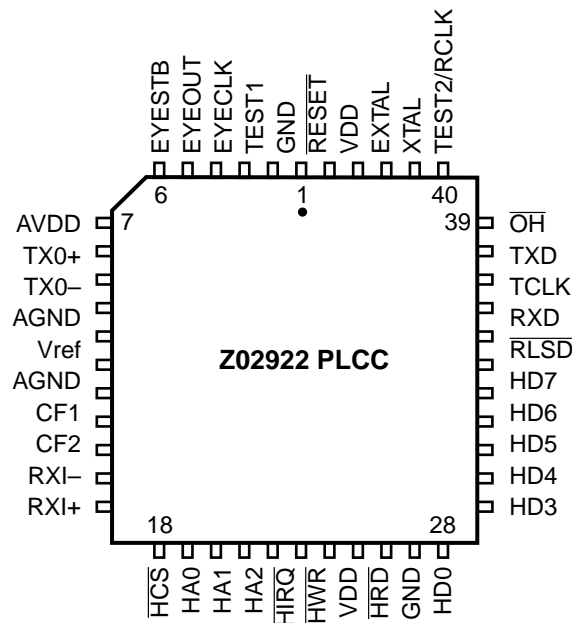

Figure 3. Z02922 44-Lead PLCC Pin Identification

Table 1. Z02922 Modem Pin Assignments

Pin No.	Symbol	Direction
1	RESET	Input
2	GND	
3	TEST1	Input
4	EYECLK	Output
5	EYEOUT	Output
6	EYESTB	Output
7	AV _{DD}	
8	TX0+	Analog Output
9	TX0-	Analog Output
10	A _{GND}	
11	Vref	Analog Output
12	A _{GND}	
13	CF1	Analog Input
14	CF2	Analog Input
15	RXI-	Analog Input
16	RXI+	Analog Input
17	AV _{DD}	
18	HCS	Input
19	HA0	Input
20	HA1	Input
21	HA2	Input
22	HIRQ	Output

Table 1. Z02922 Modem Pin Assignments

Pin No.	Symbol	Direction
23	HWR	Input
24	V _{DD}	
25	HRD	Input
26	GND	
27	HD0	Input/Output
28	HD1	Input/Output
29	HD2	Input/Output
30	HD3	Input/Output
31	HD4	Input/Output
32	HD5	Input/Output
33	HD6	Input/Output
34	HD7	Input/Output
35	RLSD	Output
36	RXD	Output
37	TCLK	Output
38	TXD	Input
39	OH	Output
40	RTS	Input
41	TEST2/RCLK	Input/Output
42	XTAL	Output
43	EXTAL	Input
44	V _{DD}	

ABSOLUTE MAXIMUM RATINGS

Symbol	Description	Min	Max	Units
V_{CC}	Supply Voltage	-0.3	+7.0	V
T_{OPR} (com)	Operating Temperature	0	+70	°C
T_{OPR} (ext)	Operating Temperature	-40	+85	°C
T_{STG}	Storage Temperature	-65	+150	°C

Stresses greater than those listed under Absolute Maximum Ratings may cause permanent damage to the device. This is a stress rating only; operation of the device at any condition above those indicated in the operational sections of these specifications is not implied. Exposure to absolute maximum rating conditions for extended periods may affect device reliability.

STANDARD TEST CONDITIONS

The DC Parameters will be tested as per the table referencing the DC Characteristics. The Z02922 tester has active loads which are used to test the loading for I_{OH} and I_{OR} .

Available operating temperature range is:

S=0°C to +70°C

E=-40°C to +85°C

Voltage Supply Range:

$+4.5\text{ V} \leq V_{CC} \leq +5.5\text{ V}$

All AC parameters assume a load capacitance of 100 pF. Add 10 ns delay for each 50 pF increase in load up to a maximum of 150 pF for the data bus and 100 pF for address and control lines.

ENVIRONMENTAL AND POWER REQUIREMENTS

The modem power and environmental requirements are shown in Tables 2 and 3.

Voltage	Current Typical @ 25°C	Current Maximum @ 0°C
+5 V _{DC} , Operating	50 mA	<=100 mA
+5 V _{DC} , Sleep	25 μA	<=125 μA

Notes:

- All voltages are ±5% DC and must have ripple less than 0.1V peak to peak. If switching supply is used, the frequency may be between 20 kHz and 150 kHz. No component of the switching frequency should be present outside of the supply greater than 500 μV peak.

Table 2. Environmental Requirements

Parameter	Value
Ambient Temperature Under Bias (Commercial Temp Range)	0°C to +70°C
Ambient Temperature Under Bias (Extended Temp Range)	-40°C to +85°C
Storage Temperature	-65°C to +150°C
Voltage on any pin to V _{SS}	-0.3V to +7V
Power Dissipation	250 mW
Soldering Temperature 0.5 sec	+230°C

**Table 3. Crystal Specification
(Required for crystal used with Z02922)**

Parameter	Value
Temperature Range (Commercial)	0°C to +70°C
Temperature Range (Extended)	-40°C to +85°C
Nominal Frequency @ 25°C	24.576 MHz
Frequency Tolerance @ 25°C	±20 PPM
Temperature Stability @ 0 °C to 70°C	±25 PPM
Calibration Mode	Parallel Resonant
Shunt Capacitance	7 pF Max.
Load Capacitance	32 ± 0.3 pF
Drive Level	1.0 mW max.
Aging, per Year Max.	± 5 PPM
Oscillation Mode	Fundamental
Series Resistance	60 ohms max.
Max. Frequency Variation with 28.8 or 35.2 pF load	±30 PPM

DC CHARACTERISTICS

Table 4. TDC Pin Characteristics

Parameter	Description	Test Conditions	Min	Typ	Max	Units
Pin Types I & I/O: Input & Input-Output						
V _{IH}	Input High Voltage		2	–	V _{CC} +0.3	V
V _{IL}	Input Low Voltage		0	–	0.8	V
I _L	Input Leakage Current	GND <V0<V _{DD}	–10	–	10	μA
Pin Types O & IO: Output & Input-Output						
V _{OH}	Output High Voltage	I _{OH} = –200 mA	2.4	–	–	V
V _{OL}	Output Low Voltage	I _{OL} = 2.2 mA	0	–	0.4	V
I _{OZ}	Tri-state Leakage Current	GND<V0<V _{DD}	–10	–	10	μA
Pin Types I-PU & I-PD: Input with Internal pull-up/pull-down resistor						
V _{IH}	Input High Voltage		2		V _{CC} +0.3	V
V _{IL}	Input Low Voltage		0		0.8	V
I _{IL}	Input Current	GND <V0<V _{DD}	–10		10	μA
Pin Type XI: Crystal Input						
V _{IH}	Input High Voltage		V _{DD} x0.8		V _{DD}	V
V _{IL}	Input Low Voltage		0			
Pin Type O-OD: Output with Open-Drain						
V _{OL}	Output Low Voltage	I _{OI} =2.2 mA	0	–	0.4	
I _{OZ}	Tri-state Leakage Current	GND<V0<V _{DD}	–10	–	10	μA
Pin Type XO: Crystal output						
V _{OH}	Output High Voltage	I _{OH} =1.0 mA	V _{DD} –1		V _{DD}	V
V _{OL}	Output Low Voltage	I _{OI} =–1.0 mA	0		1	V
Pin Type AI: Analog Input						
V _{DC}	Input Bias Offset		V _{REF} –15	V _{REF}	V _{REF} +15	mV
I _L	Input Current		–100	–	100	μA
C _{IN}	Input Capacitance		–	10	–	pF
R _{IN}	Input Resistance		–	20	–	Kohm
Pin Type AO: Analog Output						
V _O	Analog Output Voltage		V _{REF} –1.163	V _{REF}	V _{REF} +1.163	mV
V _{OFF}	Output DC Offset		V _{REF} –40	V _{REF}	V _{REF} +40	mV
R _O	Output Resistance		–	0.8	–	Ohm
C _O	Output Capacitance		–	10	–	pF
Z _I	Load Impedance		400	600	Infinite	Ohm
Pin Type PWR: Power and Ground						
V _{DD}	Digital Supply Voltage	Voltage	4.75	5	5.25	V
GND	Digital Ground		–	–	0	–
AV _{DD}	Analog Supply Voltage		V _{DD}	V _{DD}	V _{DD}	V
AGND	Analog Ground		GND	GND	GND	V
I _{DD1}	Digital Supply Current	Operating	–	45	90	mA
I _{ADD1}	Analog Supply Current	Operating	–	5	10	mA
I _{DD2}	Digital Supply Current	Sleep Mode	–	20	100	μA
I _{ADD2}	Analog Supply Current	Sleep Mode	–	5	25	μA

AC CHARACTERISTICS

Timing Diagrams

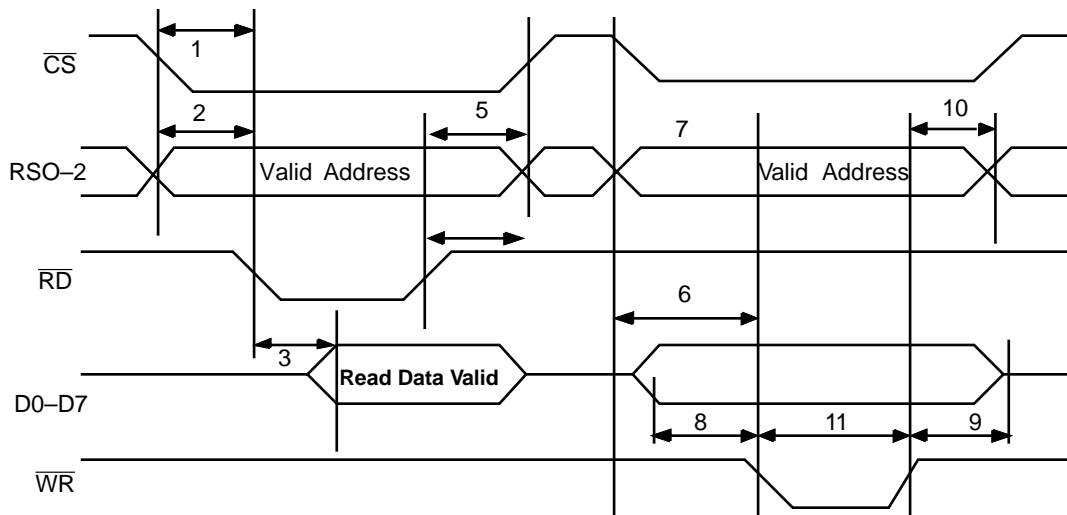

Figure 4. Microprocessor Interface Read/Write Diagram

Table 5. Microprocessor Interface Timing

Description	Parameter	Min	Typ	Max	Units
Read Timing					
HA0-2 & HCS to HRD Setup Time	1	0	—	—	ns
HA0-2 to HRD Setup Time	2	0	—	—	ns
HRD to Data Access Time	3	—	25	85	ns
HRD Data Hold	4	0	10	—	ns
HA0-2 and HCS Hold From HRD	5	0	—	—	ns
Write Timing					
HA0-2 & HCS to HWR Setup Time	6	70	—	—	ns
HCS to HWR Setup Time	7	70	—	—	ns
Data to HWR Setup Time	8	50	—	—	ns
HWR Data Hold	9	10	—	—	ns
HA0-2 and HCS Hold from HWR	10	10	—	—	ns
HWR Pulse Width	11	25	—	—	ns
Reset Timing					
Reset Pulse Width		1.0	—	—	us
Reset Rise Time		—	—	100	ns

DC CHARACTERISTICS (Continued)

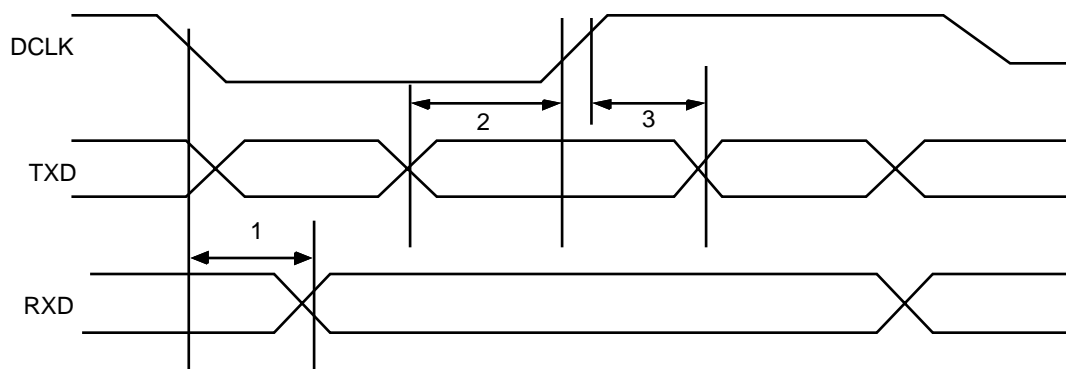

Figure 5. Serial Port Timing Diagram

Table 6. Serial Interface Timing

Description	Parameter	Min	Typ	Max	Units
RXD Data Valid Delay Time	1	–	12	–	ns
TXD Data Setup Time	2	100	–	–	ns
TXD Data Hold Time	3	100	–	–	ns

TIMING DIAGRAMS

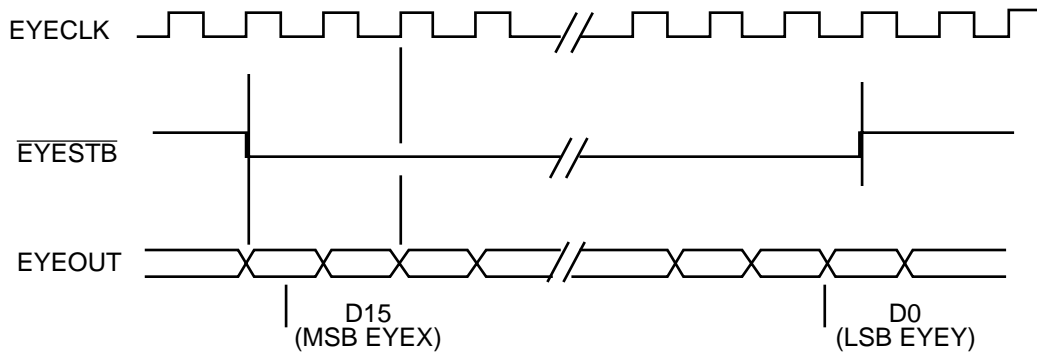

Figure 6. Eye Pattern Port Timing Diagram

Table 7. Analog Characteristics Table

Description	Parameter	Min	Typ	Max	Units
Input impedance of transformer interface	1	400	1200	–	Ohm
3 dB point of interface	2	21	26.5	32.5	kHz
External integration capacitance Type NPO (COG)	3	73	82	90	pF

ANALOG INPUTS: TYPE AI

AC Characteristics	Sym	Min	Type	Max	Units
Input Impedance (DC to V_{REF})	Z_{IN}	15K	25K	–	Ω
Power Supply Rejection	P_{SRRi}	40	–	–	dB
Input Current	I_i	–80	–	80	μA
Idle Channel Noise (3950 Hz Bandwidth)	I_{CNI}	–	–	–72	dBm
Signal to Distortion	S_{TDi}	30	–	–	dB

These characteristics below are provided for information only. They are not tested except in the functional test vectors.

Characteristics	Sym	Min	Typ	Max	Units
Input Capacitance	C_{IN}	–	10	–	pF
Input Bias	V_{DCOFF}	–	+2.5	–	V
Analog Input Voltage (peak differential), (23)	V_{PKI}	–2.362	–	+2.362	V
Analog Input Voltage (per RXI+, RXI- pin)	V_{PKIP}	–1.181	–	+1.181	V

ANALOG OUTPUTS: TYPE A0

AC Characteristics	Sym	Min	Type	Max	Units
Power Supply Rejection	P_{SRR0}	40	–	–	dB
Signal to Distortion	S_{TD0}	35	–	–	dB
Idle Channel Noise (3950 Hz Bandwidth)	I_{CNO}	–	–	–72	dBm
Out of Band Noise	N_{qo}				dBm
4–8 kHz	–	–	–20		dBm
8–12 kHz	–	–	–40		dBm
12 kHz and above in 4 kHz bandwidths	–	–	–55		dBm

Characteristics	Sym	Min	Typ	Max	Units
Output Impedance	Z_{out}	–	0.80	–	Ω
Output Capacitance	C_{out}	–	10	–	pF
Analog Output Voltage (peak differential), (24)	V_{pko}	–2.375	–	+2.375	V
Load Impedance (25)	Z_l	400	600	–	–

PIN FUNCTIONS

HD7–HD0 *Host Data Bus* (Bidirectional, Active High). HD0–HD7 constitutes an 8-bit bidirectional data bus used for the transfer of control and status information.

$\overline{\text{HCS}}$ *Host Chip Select* (Input, Active Low). When $\overline{\text{CS}}$ is low, data transfer between the data pump and the host is enabled. Data transfers to the data pump registers are 8 bits wide.

$\overline{\text{HWR}}$ *Host Write Enable Strobe* (Input, Active Low). The write enable strobe is an active low signal that is used to initiate a write operation to the data pump. During a write operation, data is sent to the data pump by the host via the host data bus.

$\overline{\text{HRD}}$ *Host Read Enable Strobe* (Input, Active Low). The read enable strobe is an active low signal that is used to initiate a read operation from the data pump. During a read operation, data is transferred out of the data pump by the host via the host data bus.

$\overline{\text{HIRQ}}$ *Host Interrupt Request* (Output, Active Low). The $\overline{\text{HIRQ}}$ is an open-drain output that can be tied through an external pull-up resistor to the digital power supply V_{DD} . The $\overline{\text{HIRQ}}$ active low data pump output can be activated when the host selects this option or requests by setting the RXIE or TXIE bits in the data pump Host Register. This pin can be connected to the host interrupt request pin to initiate host service.

$\overline{\text{RESET}}$ *Reset* (Input, Active Low). The $\overline{\text{RESET}}$ signal places the device into its reset state.

HA2–HA0 *Host Address* (Input, Active High). These three register select lines (pins) are used for addressing the “controller accessible” internal registers of the data pump. When $\overline{\text{HCS}}$ is active, the state of the HA2–HA0 is used as the internal data pump interface register address. HA2 is the most significant bit; HA0 is the least significant bit.

$\overline{\text{RLSD}}$ *Receive Line Signal Detect* (Output, Active Low). Indicates when an input signal has been detected.

RXD *Receive Data* (Output). The data pump serial receive data is presented by the data pump to the local DTE on the RXD output.

TCLK *Transmit Serial Data Clock* (Output). The serial data output clock is a synchronous data clock used to transfer serial data via V.24 compatible serial interface between the data pump and the host. The clock frequencies are 2400, 1200, 300 Hz corresponding to the supported data bit rates.

TXD *Transmit Data* (Input). The data pump accepts the serial transmit data from the local DTE on the TXD input when the data pump is configured to the serial transmit data mode. Serial transmit data mode is selected when the TDPM bit (b4) of the RAM control/data pump Status register (reg 6) is reset to 0.

$\overline{\text{OH}}$ *Off Hook Relay Control* (Output, Active Low). This pin is activated to drive a relay which engages the modem with the phone line. (Modem equivalent of picking up the receiver).

$\overline{\text{RTS}}$ *Request To Send* (Input, Active Low). The logical or of this pin and the RTSP bit (Reg 4.3) determines the data pump mode of operation. When the result of the logical or of these two bits is logic 1 then the data pump is in transmit mode at the selected speed else the data pump is in receive mode. In standby mode the state of this pin is a “don’t care”.

EYECLK *Eye Pattern Clock* (Output, Active High). Data is valid at the rising edge of clock. The EYECLK can be used to clock an external D/A converter shift register for eye pattern display.

EYEOUT *Eye Pattern Data* (Output, Active High). Serial 16-bit eye pattern output data. First 8-bits is the EYEX data and the next 8-bit data is the EYEX data. This data can be used for display on an oscilloscope X and Y-axis following D/A conversion.

EYESTB *Serial Eye Pattern Strobe* (Output, Active High). This signal can be used for loading an external D/A converter.

TXO+ *Transmit Differential Analog Output Positive* (Analog Output). The TXO+, TXO– is capable of driving a 600 ohm resistive load over a leased line or public switched telephone network via a Data Access Arrangement (DAA). The TXO– and TXO+ can be configured either as a differential or single-ended output driver.

TXO– *Transmit Differential Analog Output Negative* (Analog Output). The TXO–, TXO+ is capable of driving a 600ohm resistive load over a leased line or public switched telephone network via a Data Access Arrangement (DAA).

RXI– *Receive Differential Analog Input Negative* (Analog Input).

RXI+ *Receive Differential Analog Input Positive* (Analog Input).

PIN FUNCTIONS (Continued)

TEST1 *Test Pin 1* (Input, Active High). This is a test pin and must be tied to digital ground.

TEST2/RCLK *Test Pin 2, Receive Data Clock* (Output, Active High). This is a test pin and must be tied to digital ground through a pull-down resistor. The resistor should be low enough to ensure this pin floats below 0.8V when the part is in the reset state. After reset, this pin becomes the Receive Data Clock Output. The resistor should be high enough such that the output can be driven to logic "1". This is a synchronous data clock used to transfer serial data via V.24 compatible serial interface between the data pump and the host. The clock frequencies are 2400, 1200, 300 Hz corresponding to the supported data bit rates.

Vref *Reference Voltage* (Output, Active High). An internally generated reference voltage.

XTAL *Crystal Oscillator Output* (Output, Active High). The data pump chip can be connected to an external crystal

circuit consisting of 24.576 MHz parallel resonant crystal with a resistor and two capacitors.

EXTAL *Crystal Oscillator Input* (Input, Active High). The data pump chip can be connected to an external circuit consisting of a 24.576 MHz parallel resonant crystal with a resistor and two capacitors.

CF1 and CF2 *Integration Capacitor PINS 1 and 2* (Analog Input). Connect an 82pF capacitor between CF2 and CF1 to complete the internal feedback integration filter for improved analog A/D performance.

GND *Digital ground*–0 Volts.

V_{DD} *Digital Power*–5 Volts.

AV_{DD} *Analog Power*–5 Volts

AGND *Analog Ground*–0 Volts.

HARDWARE INTERFACE SIGNALS

The Z02922 interface consists of the V.24 compatible Serial Interface Port, 8-bit Host Microprocessor Interface, Eye Pattern Interface, Voice Band AFE, System Signals,

and Overhead Signals. The Z02922 functional hardware signals diagram is shown in Figure 7. Any signal that is active low is represented by a slash before the signal name.

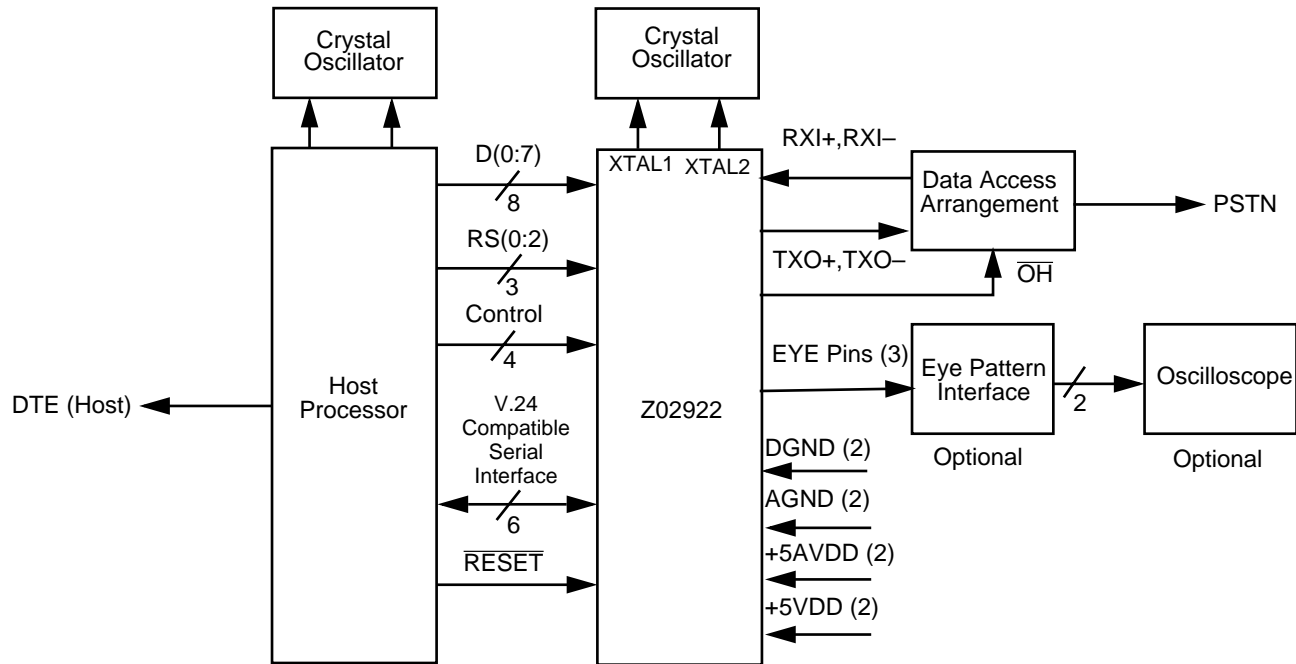

Figure 7. Modem Functional Interconnect Diagram

V.24 Compatible Serial Interface Port

The V.24 compatible Serial Interface Port provides no parallel-to-serial/serial-to-parallel conversion hardware. The V.24 compatible serial interface port consists of 7 signal pins:

Pin	Signal Name
TxD	Transmit Data
RxD	Receive Data
$\overline{\text{RTS}}$	Request To Send
$\overline{\text{CTS}}$	Clear To Send
$\overline{\text{RLSD}}$	Receive Line Signal Detect
TCLK	Transmit Data Clock
RCLK	Receive Data Clock

Host Port Interface

The host parallel port interface consists of 15 signal pins: 8-bit bidirectional data bus pins (HD7–HD0), 3-bit Address bus (HA2–HA0), 4 control lines, which include the Host Read ($\overline{\text{HRD}}$), Host Write ($\overline{\text{HWR}}$), Host Chip Select ($\overline{\text{HCS}}$) and Host Interrupt Request ($\overline{\text{HIRQ}}$). Multiple interrupt

sources are provided in the Z02922, each of which can be masked under host control.

The host parallel interface allows the host access to data pump RAM address and data bits, transmit and receive data, RAM control and status bits, and read data pump status bits. The host can access eye pattern functions, generate transmit and receive tones and access adaptive equalizer coefficients in modem-type applications.

The host parallel interface is compatible with standard 8-bit microprocessors, which include the Z8 and Z80 bus.

Eye Pattern Interface

The eye pattern interface consists of 3 pins; Eye Pattern Data (EYEOUT), Eye Pattern Clock (EYECLK), and Eye Pattern Strobe (EYESTB). Sixteen bits of data are serially transmitted via EYEOUT, under control of EYESTB and EYECLK. The first byte is the X-coordinate and the second byte is Y-coordinate of the sample. The least significant bit is presented first for both X and Y coordinate. A schematic of an eye pattern circuit is found in Figure 12 at the end of this specification.

TECHNICAL SPECIFICATIONS (Continued)

The Eye Pattern Data, EYEOUT outputs a serial bit stream containing data for display of the eye pattern on an oscilloscope after D/A conversion. Eight bits of the X-axis data and eight bits of the Y-axis are output as a single sixteen bit data stream with the X-axis data first. EYEOUT is synchronous with the rising edge of EYECLK. EYEOUT is valid only while the EYESTB is low. Data is shifted out MSB first.

Data on eyeout is shifted out on each rising edge of the 1.536MHz EYECLK. EYEOUT data is valid on the following edge of the Eye Pattern Clock, EYECLK.

The EYEOUT data is valid when the Eye Pattern Strobe, EYESTB is low. EYESTB changes state on the rising edge of EYECLK.

TECHNICAL SPECIFICATIONS

Configurations and Data Rates

Table 8 provides the selectable options, the supported data rate as well as baud rate and the modulation method.

DTMF tones for PSTN auto dialing, and the supervisory tones for call establishment. The tone detection provides support for call progress monitoring. The detector can also be user-programmed to recognize up to 16 tones.

Tone Generation and Tone Detection

The Z02922 provides comprehensive and flexible tone generation and detection. This includes all tones needed to establish a circuit connection and to setup and control a communication session. The tone generation furnishes the

Data Encoding

The data encoding for the Z02922 meets ITU-T recommendations as well as Bell standards.

Table 8. Selectable Configurations

Configuration	Modulation	Carrier Freq.	Data Rate (bps)	Symbol Rate (baud)	Bits Per Symbol	Constellation Points
V.22 bis 2400	QAM	1200/2400	2400	600	4	16
V.22 bis 1200	DPSK	1200/2400	1200	600	2	4
V.22 1200	DPSK	1200/2400	1200	600	2	4
V.23 1200/75	FSK	1700/420	1200/75	1200/75	1	—
V.21	FSK	1080/1750	300	300	1	—
Bell 212A	DPSK	1200/2400	1200	600	2	4
Bell 103	FSK	1170/2125	300	300	1	—

Notes:

1. Configuration is selected through the RAM location Config.
2. QAM=Quadrature Amplitude Modulation FSK=Frequency Shift Keying ,DPSK=Dual Phase Shift Keying

TRANSMITTED DATA SPECTRUM

The transmitted data spectrum with compromise equalization disabled is shaped in the baseband by the finite im-

pulse response (FIR) filter. Table 9 reflects the spectrum characteristics.

Table 9. Spectral Shaping

Mode	Carrier Freq	Spectral Power Shaping Function
V.22	1200	sqrt 75% Raised Cosine at 600 baud
V.22bis	2400	sqrt 75% Raised Cosine at 600 baud

Note: The carrier and the spectral shaping are selected automatically according to the configuration.

TRANSMIT LEVELS

The transmit output level of the Z02922 is programmable in 1 dBm decrements from -6 dBm to -43 dBm with a default value of -10 dBm when measured differentially across pins TX0+ and TX0- with a sinusoidal waveform.

Note: To avoid saturation the Tx level should be set to -6 dBm or lower by the host. If a higher transmit level is required, it can be accomplished using external op amps.

RECEIVER LEVELS

The timing recovery circuit can track a $\pm 0.01\%$ (100 ppm) frequency error in the associated transmit timing source with less than 1.0 dB degradation in performance.

Carrier Recovery

The recovery circuit can track a ± 7 Hz frequency offset in the receiver carrier with less than 1.0 dB degradation in performance.

Clamping

Received Data (RXD) is clamped to a constant mark whenever RLSD is off.

SOFTWARE INTERFACE

The host microprocessor communicates with the Z02922 via the parallel microprocessor bus interface. Access is provided to a set of seven 8-bit Interface Registers, and through these registers, to Z02922 RAM memory loca-

tions. This interface allows the host to request modem status information and receive data, control the configuration, and load data for transmit. Table 10 is the Parallel Interface Register map.

Table 10. Interface Register Map

Function	Register Number	RS2-0 b2b1b0	MSB* Bit 7	Bit 6	Bit 5	Bit 4	Bit 3	Bit 2	Bit 1	LSB** Bit 0	Access Method
RAM Access low	0	000	RAMDL								R/W
RAM Access high	1	001	RAMDH								R/W
RAM Access Address	2	010	RAMAL								W
Parallel Data	3	011	DATAP								R/W
RAM Control & Status	4	100	TXIE	RXIE	RAMIE	TPDM	RTSP	RAMRW	RAMRQ	RAMAH	R/W
Modem Status	5	101	TXI	RXI	RAMI	DPBUSY	Reserved	RTRND	CDET	RES	R
HDLC	7	111	0	0	0	0	0	TEND	RXERR	EOF	R/W

Microprocessor Interface Register and Bit Definitions:

Reg0, Reg1 RAMDL, RAMDH: DATA PUMP RAM DATA REGISTERS. RAMDL is the least significant byte, RAMDH is the most significant byte. After a data pump RAM read operation has completed, these registers contain the requested data. When a data pump RAM write operation is started, these registers contain the data written to data pump RAM.

Reg2 RAMAL: DATA PUMP RAM DATA ADDRESS. When a data pump RAM read or write operation is started, this byte contains the lower 8 bits of the RAM address. Register Reg4.RAMAH is the high bit of the RAM address.

Reg3 DATAP: DATA PUMP PARALLEL DATA. This register contains data transferred to or from the remote modem during parallel modem (see register Reg4.TPDM). Upon any reset, and when Config.MODE=0 (standby), the data pump places its firmware version number in register DATAP.

SOFTWARE INTERFACE (Continued)

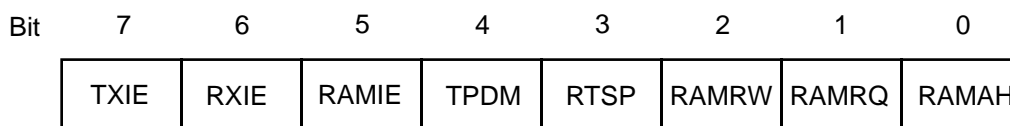

Table 11. REG4: RAM Control Register

SYMBOL	POSITION	NAME AND DESCRIPTION
RAMAH	REG 4.0	RAM Address High Bit. This is the most significant bit of the data pump RAM address. This bit should be set to 1 when accessing a data pump RAM address that is greater than 255 else this bit should be set to 0.
RAMRQ	REG 4.1	Data Pump RAM Access Request Bit. Set this bit to 1 to request a read or write of the data pump RAM. The data pump will set this bit to 0 when the request has been fulfilled.
RAMRW	REG 4.2	Data Pump RAM Read/write Bit. Set this bit to 0 to request a read of data pump RAM; 1 to request a write of data pump RAM.
RTSP	REG 4.3	Register Request to Send Bit. This bit is OR'd with the hardware RTS signal received by the data pump on its $\overline{\text{RTS}}$ pin. The host uses either $\overline{\text{RTS}}$ or $\text{RTSP}=1$ to inform the data pump the host is transmitting data. To control the data pump using the $\overline{\text{RTS}}$ signal, set RTSP to 0. To control the data pump using RTSP , hold $\overline{\text{RTS}}$ high.
TPDM	REG 4.4	Select Parallel Data Mode. Setting this bit selects the parallel data mode. Resetting it selects the serial data mode.
RAMIE	REG 4.5	RAM Interrupt Enable Bit. Setting this bit will allow the data pump to interrupt the host when a RAM read/write request has been completed.
RXIE	REG 4.6	Receive Data Interrupt Enable Bit, Parallel Data Mode Only. This bit, when set, will cause the data pump to generate an interrupt whenever the RXI bit is set.
TXIE	REG 4.7	Transmit Data Interrupt Enable Bit, Parallel Data Mode Only. This bit, when set, will cause the data pump to generate an interrupt whenever the TXI bit is set.

Note: All the bits in this register (REG 4) default to logic 0 upon power-up or after reset sequences are completed.

Bit	7	6	5	4	3	2	1	0
	TXI	RXI	RAMI	DPBUSY	Reserved	RTRND	CDET	RES

Table 12. REG5: Data Pump Status Register

SYMBOL	POSITION	NAME AND DESCRIPTION
RES	REG 5.0	Data Pump in RESET Mode. This bit is set whenever the data pump is in RESET mode due to a hardware reset or power-on. The data pump sets RES=0 when it completes reset.
CDET	REG 5.1	Carrier Detect. The data pump sets CDET=1 when it enters any data mode and is ready to transmit data. In V.29 receive, the data pump sets CDET=1 when it enters V.29 data mode and is ready to receive data. The data pump sets CDET=0 during retrains (see Reg5.RTRND) and when no signal is detected from the remote modem. See locations RLSDOnThresh and RLSDOffThresh for more information. CDET is inverted and reflected on the data pump's \overline{RLSD} pin, so if CDET=1, \overline{RLSD} is low (asserted). Upon any reset, or when the host sets Config.MODE=0 (standby), the data pump sets CDET=0.
RTRND	REG 5.2	Retrain Detect, 2400 bps (V.22bis data mode only). Retrain sequence detected when this bit is set. The data pump has detected a retrain request sequence from the remote modem.
DPBUSY	REG 5.4	Data Pump Busy. This bit is set whenever the data pump starts transmitting data and RTSP=1. When the link is to be terminated, setting RTSP to 0 will cause this bit to be reset after the data pump has finished transmitting the last of the data in its internal buffers. When this bit has been reset, it is safe to set Config.MODE to standby mode (0) and hang up the telephone, thus terminating the connection. It also indicates when digits are being dialed during timed dialing operation. Upon any reset, or when the host sets Config.MODE=0 (standby) the data pump sets DPBUSY=0. This bit is not valid during HDLC operation.
RAMI	REG 5.5	Data Pump RAM Interrupt Status. This bit is set when the data pump has processed a RAM read/write request.
RXI	REG 5.6	Receive Interrupt Status. This bit is set when the data pump is in parallel data transfer mode (TPDM=1) and the data pump has written a new octet to the DATAP register. A read from the DATAP register will clear this bit.
TXI	REG 5.7	Transmit Interrupt Status. This bit is set when the data pump is in parallel data transfer mode (TPDM=1) and the data pump has read the DATAP register. A write to the DATAP register will clear this bit.

Note: The RXI bit is set to logic 1 after the reset sequences. All other bits in this register (REG 5) default to logic 0 upon power up or after reset sequences are completed.

SOFTWARE INTERFACE (Continued)

Bit	7	6	5	4	3	2	1	0
	0	0	0	0	0	TEND	RXERR	EOF

Table 13. REG7: HDLC Register.

SYMBOL	POSITION	NAME AND DESCRIPTION
EOF	REG 7.0	Receive End of Frame. The data pump sets EOF=1 when an HDLC frame has been completely received, i.e., when frame data has been received and a closing HDLC flag or HDLC Abort condition is received. If the frame was correctly received, the data pump also sets Reg5.RXERROR=0, Reg5.RXI=1, and DATAP=7EH. See Reg7.RXERROR for a description of CRC errors and HDLC Aborts. EOF reflects whether the current register DATAP value indicates the end of receipt of an HDLC frame. When the first data byte of the next HDLC frame is received, or if an HDLC Abort condition is received when no HDLC frame data was being received, the data pump sets EOF=0. This may occur only 8 bit times after the data pump sets EOF=1.
RXERR	REG 7.1	Receive Error. If an HDLC frame contains a CRC error, or an HDLC Abort condition is received, the data pump sets RXERROR=1, Reg5.RXI=1, and DATAP=7EH or FFH. If the frame had a CRC error, DATAP=7EH. If an HDLC Abort condition was received, DATAP=FFH. RXERROR reflects whether the current register DataP contents indicate an error. When the first data byte of the next HDLC frame is received, the data pump sets RXERROR=0. This may occur only 8 bit times after the data pump set RXERROR =1.
TEND	REG 7.2	Transmit End of Frame. The data pump sets TEND=1 when it closes an HDLC frame being transmitted. The data pump sets TEND=0 after transmitting the CRC bytes, when it starts transmitting the closing flag of the HDLC frame. The data pump closes an HDLC frame when the host does not provide data to transmit (see DATAP) in time to be included in the HDLC frame.

Note: All the bits in this register (REG 7) default to logic 0 upon power up or after reset.

All undefined bits of this register are reserved. The host should write logical 0 to all reserved bit positions when writing this register. The host should ignore the reserved bits when reading this register.

Reg7 Data Pump Register 7 These bits represent the state of HDLC frames when the data pump is in the HDLC framing mode. These bits are valid only if Bufctrl.HDLC=1. The host should refrain from writing Reg7 to avoid changing the values of bit fields set by the data pump. Bits not defined above are reserved or not available for use.

The two CRC checksum bytes in received HDLC frames are provided to the host.

Upon any reset, or when the host sets Config.MODE=0 (standby) the data pump sets TEND=0, RXERROR=0 and EOF=0.

The host reads register Reg7 immediately before DATAP.

RAMI, RXI, AND TXI INTERRUPTS

The 3 most significant bits in the RAM Control and data pump Status Registers define the interrupt masks for RAMI, RXI, and TXI. The RAMIE, RXIE, and TXIE enable bits in the RAM Control Register are logically ANDed with its corresponding interrupt bits in the data pump Status Register. The outputs are then logically ORed and drive the $\overline{\text{HIRQ}}$ pin, which provides an interrupt to the host interrupt (See Figure 8).

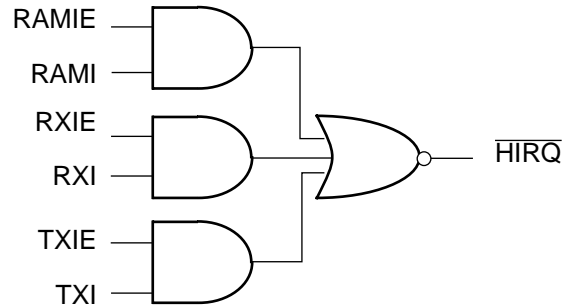

Figure 8. Host Interrupt Circuit Diagram

INTERFACE RAM

RAM locations are named <variable name>, <list field> For example, Config.MCUCTRL refers to the MCUCTRL bit in the variable Config.

The interface RAM is also used by the data pump for normal operations. Therefore all writes to the interface RAM should be of the form Read-Modify-Write where only the bits that need to be changed are changed. All undocumented bits are reserved and should be preserved.

Important Notes

1. Do not read or write data pump RAM more frequently than once every 2 msec.
2. Data pump RAM reads or writes requires approximately 0.1 msec to complete.

3. Data pump RAM writes take effect at different times depending upon the location being written to. In general, during data modes, writes take effect at the end of the next baud period. In general, during other modes of operation, writes take effect in 0.1 msec.
4. Writing Reg4, for example to set Reg4.TXIE=0 in an interrupt handler, while waiting for the data pump to set Reg4.RAMRQ=0 in the background may cause unwanted side effects. Setting Reg4.RAMRQ=1 may cause the data pump to repeat the read/write request if the data pump had just set Reg4.RAMRQ=0, whereas setting Reg4.RAMRQ=0 may abort the RAM read/write request.

DATA PUMP INTERFACE RAM ACCESS METHOD

To write to data pump RAM:

1. Write data to RAMDL & RAMDH.
2. Write the lower 8 bits of the address of the data pump RAM location to register RamAL.
3. With one write operation to register R4, set the high bit of the data pump RAM address in R4.RAMAH, set R4.RAMRW=1 and set R4.RAMRQ=1.
4. Wait until the data pump sets R4.RAMRQ=0.

To read from data pump RAM:

1. Write the lower 8 bits of the address of the data pump RAM location to register RamAL.
2. With one write operation to register R4, set the high bit of the data pump RAM address in R4.RAMAH, set R4.RAMRW=0 and set R4.RAMRQ=1.
3. Wait until RAMRQ is reset to 0 by the data pump or until RAMI=1.
4. Read data from RAMDL & RAMDH.

Reads and writes to the data pump RAM may take as much as 105us to complete.

MODEM DATA PUMP RAM MAP

Table 14. Modem Data Pump RAM Map

Mnemonic	Address (Hex)	Access Mode	Description
Config	01FF	R/W	Data Pump Configuration
Trnctrl	01FE	R/W	Training Control
Bufctrl	01FD	R/W	Buffer Control
ToneStatus	01FC	R/W	DTMF and Tone Control Status
Dpctrl	01FA	R/W	Data Pump Miscellaneous Controls
MStatus	01F7	R/W	Modem Control and Status
EQMMaxThresh	01F6	R/W	MSE Maximum Threshold
RLSDOffThresh	01F5	R/W	RLSD Off Threshold
RLSDOnThresh	01F4	R/W	RLSD On Threshold
CONN_Mode	01F0	R/W	Connection Speed After Handshake is Complete
DTMFh_lev	01A1	R/W	DTMF High Band Transmit Level
DTMFl_lev	01A0	R/W	DTMF Low Band Transmit Level
ToneGenA	0191	R/W	Tone Generator A
ToneGenB	0196	R/W	Tone Generator B
TxLevel	0185	R/W	Modem Transmit Level
Seq3Count	18E	R/W	Dial Timer Inter-Pulse Count
Seq2Count	18D	R/W	Dial Timer Off Count
Seq1Count	18C	R/W	Dial Timer On Count
BiquadA	0155–015E	R/W	Biquad A Coefficient
BiquadB	015F–0168	R/W	Biquad B Coefficient
DTD0–DTD15	0145–0154	R/W	Tone Detector Coefficients
EQMlev	092	R/W	Eye Quality Monitor Level
BiQuadOffThresh	052	R/W	Biquad Detectors Off Point
BiQuadOnThresh	051	R/W	Biquad Detectors On Point
DTD0Lev–DTD15Lev	026–035	R/W	Tone Detector Levels
DTDThresh	03	R/W	Tone Detector Threshold
DTDStatus	00	R/W	Discrete Tone Detector Status

INTERFACE RAM DEFINITIONS

Table 15. Modem Data Pump Word Definitions

Register & Address (hex)	Default Value	Function and Explanation
Config 01FF	0H	Data pump configuration register
	b15	Unused. Set this bit=0.
	b14	ORG (Set Originate Mode: all modes) If ORG=1, then the modem is in originate mode. Otherwise, it is in answer mode. Be sure to set ORG before or at the same time as Config.MODE, not afterwards.
	b13	ERROR (Data Pump Error: all modes) This bit is set to 1 when the data pump detects an internal error condition such as an invalid Config code. The host should reset the data pump.
	b12	ECHOPRTEN (Echo Protect Tone Enable: V.29) This bit controls the transmission of the Echo Protect Tone (EPT) during a V.29 transmit handshake. EPT is an unmodulated carrier set at -8 dBm relative to the transmit level (see TxLevel). If set, the data pump will transmit an EPT before transmitting the carrier.
	b11	ECHOPRTLEN (Echo Protect Tone Length: V.29) This bit controls the length of the EPT tone. 0 (default) selects a 30 ms EPT; 1 selects a 185 ms EPT.
	b10	MCUCTRL (Manual Handshake: V.22/V.22bis/B212A) This bit allows the host to control the handshake process in V.22bis. (See Manual Handshake Procedures for more information).
	b9	EXTSQLCH (Extended Squelch: V.29) Set this bit to extend segment 1 (transmitter squelch or Silence) in the V.29 training sequence from 20 ms to 140 ms.
	b8	SRESET (Soft Reset: all modes) Set this bit to soft reset the data pump. The data pump sets SRESET to 0 when the software reset completes.
	b7	Unused. Set this bit=0.

INTERFACE RAM DEFINITIONS (Continued)

Table 15. Modem Data Pump Word Definitions

Register & Address (hex)	Default Value	Function and Explanation																														
Config (continued)	b0..6	<p>MODE (Data Mode Configuration: selects a mode) Selects data pump operation mode, as follows. All modes unlisted below should be considered reserved. The host should read MODE once after writing it to allow the data pump enough time to begin operation in the new mode. Setting MODE=0 (standby) starts the idle mode of operation, not the power-saving sleep mode. The mode table follows:</p> <table border="1"> <thead> <tr> <th colspan="2">Data Mode Specified</th> </tr> </thead> <tbody> <tr><td>0</td><td>Standby</td></tr> <tr><td>1</td><td>Transmit tones using both generators simultaneously</td></tr> <tr><td>2</td><td>Detect tones/BiQuads using all discrete tone detectors and biquad tone detectors simultaneously</td></tr> <tr><td>3</td><td>Dial</td></tr> <tr><td>7</td><td>Sleep Mode</td></tr> <tr><td>8</td><td>V.22bis 2400 bps/1200 bps mode</td></tr> <tr><td>9</td><td>V.22 1200 bps mode</td></tr> <tr><td>B</td><td>Bell 212A 1200 bps mode</td></tr> <tr><td>10</td><td>V.21 300 bps mode</td></tr> <tr><td>11</td><td>Bell 103 300 bps mode</td></tr> <tr><td>13</td><td>V.23 1200 bps Tx/75 bps Rx mode</td></tr> <tr><td>14</td><td>V.23 75 bps Tx/1200 bps Rx mode</td></tr> <tr><td>20</td><td>V.29 and V.29 Quick Connect 9600 bps Data Mode</td></tr> <tr><td>21</td><td>V.29 and V.29 Quick Connect 7200 bps Data Mode</td></tr> </tbody> </table>	Data Mode Specified		0	Standby	1	Transmit tones using both generators simultaneously	2	Detect tones/BiQuads using all discrete tone detectors and biquad tone detectors simultaneously	3	Dial	7	Sleep Mode	8	V.22bis 2400 bps/1200 bps mode	9	V.22 1200 bps mode	B	Bell 212A 1200 bps mode	10	V.21 300 bps mode	11	Bell 103 300 bps mode	13	V.23 1200 bps Tx/75 bps Rx mode	14	V.23 75 bps Tx/1200 bps Rx mode	20	V.29 and V.29 Quick Connect 9600 bps Data Mode	21	V.29 and V.29 Quick Connect 7200 bps Data Mode
Data Mode Specified																																
0	Standby																															
1	Transmit tones using both generators simultaneously																															
2	Detect tones/BiQuads using all discrete tone detectors and biquad tone detectors simultaneously																															
3	Dial																															
7	Sleep Mode																															
8	V.22bis 2400 bps/1200 bps mode																															
9	V.22 1200 bps mode																															
B	Bell 212A 1200 bps mode																															
10	V.21 300 bps mode																															
11	Bell 103 300 bps mode																															
13	V.23 1200 bps Tx/75 bps Rx mode																															
14	V.23 75 bps Tx/1200 bps Rx mode																															
20	V.29 and V.29 Quick Connect 9600 bps Data Mode																															
21	V.29 and V.29 Quick Connect 7200 bps Data Mode																															

Table 15. Modem Data Pump Word Definitions

Register & Address (hex)	Default Value	Function and Explanation
Trnctrl	01FE	0H
Training Control Register		
The data pump sets this location to its default value upon any reset and when the host sets Config.MODE=0 or to any data mode. This RAM location controls the handshake process during a manual training process (see Manual Handshake Procedure for an example on the use of this interface). This RAM location has no effect once data mode is entered (Trnctrl=5 or 6).		
b7		SB1DET —Scrambled Binary 1 Detected (1200 bps or 2400 bps). Debounced through 30 ms.
b6		S1DET —S1 Detected: debounced through 27 ms
b5		USB1DET —Unscrambled Marks Detected (1200 bps)
b4		SB0DET —Scrambled Binary 0 Detected (1200 bps or 2400 bps)
b3		V22BIS Force 16 Way Decisions.
b0–2		TXCTRL Transmitter Control. Set TXCTRL to control the output of the data pump, using the following table as a guide. The default frequency for the transmitted tone (TXCTRL=7) is 2225 Hz, and may be changed after setting TXCTRL by changing ToneGenA appropriately. The tone level is controlled by TxLevel.
V.22/Bell 212A/V.22bis Sequence Transmitted		
Value		
0	Silence: squelch transmitter	
1	Transmit unscrambled binary 1 at 1200 bps	
2	Transmit S1 signal	
3	Transmit scrambled binary 1 at 1200 bps	
4	Transmit scrambled binary 1 at 2400 bps	
5	Begin V.22 1200 bps	
6	Begin 2400 bps data mode	
7	Transmit tone	
FSK Sequence Transmitted		
Value		
0	Silence: squelch transmitter	
1	Transmit marks (binary 1)	
2	Transmit spaces (binary 0)	
5	Begin FSK Data Mode	
7	Transmit tone	

INTERFACE RAM DEFINITIONS (Continued)

Table 15. Modem Data Pump Word Definitions

Register & Address (hex)	Default Value	Function and Explanation
Bufctrl 01FD	0H	Buffer Control Register
	b15..b8	Set these bits=0 when setting Bufctrl.HDLC=1.
	b7	HDLC (Set HDLC Mode: all data modes) Set HDLC mode. When parallel data transfer mode is selected (TPDM=1) and HDLC is set, the data pump will transfer data using the synchronous HDLC mode. In serial mode (TPDM=0), this bit has no effect. The host should set bits 8–15 to 0 when it sets this bit to 1.
	b3	SCRDIS (Scrambler Disable: V.22, V.22bis, Bell 212A, V.29) Set this bit to disable the transmitter scrambler. Takes precedence over TRNCTRL/TXCTRL.
	b2	TXMHL D (Hold Tx Output to Marks: all modes) Set this bit to force the data pump to transmit only marks to the remote modem, disregarding data received from the host.
	b1	DSCRDIS (Descrambler Disable: V.22, V.22bis, Bell 212A, V.29). Set this bit to disable the receiver descrambler.
	b0	RXMHL D (Hold Rx Output to Marks: all modes) Set RXMHL D=1 to cause the data pump to transmit only marks to the host, disregarding data received from the remote modem.

Table 15. Modem Data Pump Word Definitions

Register & Address (hex)	Default Value	Function and Explanation																																		
ToneStatus 01FC	080H	Biquad Tone Detector Control and Status, Dial Control The data pump sets this location to its default value upon any reset.																																		
	b15	TONEA (Tone A Detected) The tone frequency programmed in biquad detector A has been detected if this bit is set.																																		
	b14	TONEB (Tone B Detected) The tone frequency programmed in biquad detector B has been detected if this bit is set.																																		
	b13	Cascade Biquad Tone Detectors A & B The two 4th order biquad tone detectors can be cascaded to form a single 8th order biquad tone detector if this bit is set by the host. The result of the cascaded biquad tone detector is available in ToneStatus.TONEA.																																		
	b7	TONEDIAL (Use DTMF to Dial) This bit causes the data pump to use DTMF tone dialing when in dialing mode (Config.MODE=3).																																		
	b5	SQRDIS (Squarer Disable) Set SQRDIS=1 to cause the data pump to provide the output of biquad detector A directly to the input of biquad detector B, without first squaring it. SQRDIS is valid only when the biquad tone detectors are cascaded (see ToneStatus.CASCADE).																																		
	b4	TIMEDIAL (Timed Dialing) Set TIMEDIAL=1 to cause the data pump to generate timed DTMF tones or pulse dialing. If TIMEDIAL=0, continuous dialing is used.																																		
	b0–b3	DIAL DIGIT The DTMF digit to be dialed is set here before Config is set for DTMF transmit. See the following table to determine how to set this parameter. For pulse dialing, only digits 0 through 9 are valid:																																		
		<table border="1"> <thead> <tr> <th>Digit</th> <th>Value</th> </tr> </thead> <tbody> <tr><td>0</td><td>0</td></tr> <tr><td>1</td><td>1</td></tr> <tr><td>2</td><td>2</td></tr> <tr><td>3</td><td>3</td></tr> <tr><td>4</td><td>4</td></tr> <tr><td>5</td><td>5</td></tr> <tr><td>6</td><td>6</td></tr> <tr><td>7</td><td>7</td></tr> <tr><td>8</td><td>8</td></tr> <tr><td>9</td><td>9</td></tr> <tr><td>*</td><td>10</td></tr> <tr><td>#</td><td>11</td></tr> <tr><td>A</td><td>12</td></tr> <tr><td>B</td><td>13</td></tr> <tr><td>C</td><td>14</td></tr> <tr><td>D</td><td>15</td></tr> </tbody> </table>	Digit	Value	0	0	1	1	2	2	3	3	4	4	5	5	6	6	7	7	8	8	9	9	*	10	#	11	A	12	B	13	C	14	D	15
Digit	Value																																			
0	0																																			
1	1																																			
2	2																																			
3	3																																			
4	4																																			
5	5																																			
6	6																																			
7	7																																			
8	8																																			
9	9																																			
*	10																																			
#	11																																			
A	12																																			
B	13																																			
C	14																																			
D	15																																			

INTERFACE RAM DEFINITIONS (Continued)

Table 15. Modem Data Pump Word Definitions

Register & Address (hex)	Default Value	Function and Explanation
Dpctrl	01FA	0H
Data Pump Miscellaneous Controls		
Do not modify this location during automatic handshake or retrain. The data pump sets this location to its default value upon any reset.		
b15		TXSQLCH (Squelch Transmitter: all modes)
b14		AGCFRZ (Freeze Autogain Control: V.22/V.22bis/Bell 212A) Set to 1 to freeze AGC adaptation.
b13		TXSTRN (Set V.29 Transmit Short Train) Set to 1 to enable V.29 short train transmitter handshake sequence. The remote receiver must also be set for short train.
b12		RXSTRN (Set V.29 Receive Short Train) Set to 1 to enable V.29 short train receiver handshake sequence. The remote transmitter must also be set for short train.
b10–11		LEQTYPE (Link Equalizer Type) Set LEQTYPE to 0 for a flat line equalizer, or LEQTYPE to 1 for a 3002 line equalizer.
b9		GTEEN (Guard Tone Enable: V.22/V.22bis/Bell 212A) This bit controls whether a V.22/V.22bis/Bell 212A link is made with a guard tone or not. If it is set, a guard tone is transmitted along with the carrier. Must not be enabled in modes other than V.22, V.22bis, and Bell 212A! This bit must be set prior to selecting the mode in Config.
b8		GTSSEL (Guard Tone Select: V.22/V.22bis/Bell212A) This bit selects the guard tone frequency. 0=550 Hz, 1=1800 Hz. This bit must be set prior to selecting the mode in Config.
b4		EQE (EQMlev > EQMMaxThresh: V.22, V.22bis, V.29, BELL 212A)—The data pump sets EQE=1 when EQMlev exceeds the threshold set in EQMMaxThresh.
b3		EQFRZ (Freeze Equalizer: all modes) Set to 1 to freeze adaptive equalizer (AEQ) adaptation. AEQ coefficients are lost when a mode change (in Config) occurs.
b2		TSPACE (Select T-spaced vs. T/2-spaced Equalizer: V.29) This bit, when set, selects a T-spaced AEQ. When reset, it selects a T/2 spaced AEQ. V.22/V.22bis/Bell 212A modes always use a T/2-spaced equalizer.

Table 15. Modem Data Pump Word Definitions

Register & Address (hex)	Default Value	Function and Explanation
MStatus	01F7 0H	Modem Control and Status
	b11	RETRAIN (Force a Retrain: V.22bis) When set, this bit will force a retrain if the data pump has a V.22bis connection. The CDET (Register 5 bit 1) bit will be set to 0 when the retrain has begun. The CDET bit will be set to 1 when the retrain has been completed. The data pump sets RETRAIN=0 when retrain begins and when the host sets Config.MODE to any data mode.
	b2	OFFHOOK (Enable Off-hook Relay) The data pump sets the \overline{OH} signal to the inverted value of this bit. For example, when OFFHOOK=1, the data pump sets \overline{OH} low. When \overline{OH} is low, the off-hook relay should be closed so the signal from the telephone line is presented to the data pump. The data pump sets OFFHOOK to 1 when the host sets Config.MODE to 3 (dial), or to any data mode. The data pump sets OFFHOOK to 0 upon any reset. Modify OFFHOOK only when Config.MODE=0 (standby) to avoid interference with the data pump's use of this bit.
EQM MaxThresh	01F6 400H	EQM Maximum Threshold This is the upper acceptable limit for the Eye Quality Monitor (EQM). During V.22, V.22bis or Bell 212A data mode, when EQMlev exceeds EQMMaxThresh, the data pump sets Dpctrl.EQE to 1. The data pump sets this location to its default value upon any reset. Changes in value take effect at the end of the next baud period.
RLSOffThresh	01F5 -48 dBm	Received Line Signal Detect "off" Threshold
RLSOnThresh	01F4 -43 dBm	Received Line Signal Detect "on" Threshold The upper and lower thresholds of the received telephone line energy. If Reg5.CDET=1 and the telephone line energy falls below RLSOffThresh then the data pump sets Reg5.CDET=0. If Reg5.CDET=1 and the telephone line energy rises above RLSOnThresh then the data pump sets Reg5.CDET=1. These thresholds stabilize Reg5.CDET by hysteresis when RLSOffThresh is set to a lower value than RLSOnThresh. Use the formula
$RLSD_{val} = 10^{(thresh)/20} \cdot 32767$		
where thresh is specified in dBm and less or equal to 0. The data pump sets this location to its default value upon any reset. Changes in value take effect after the next baud period.		

INTERFACE RAM DEFINITIONS (Continued)

Table 15. Modem Data Pump Word Definitions

Register & Address (hex)	Default Value	Function and Explanation																				
CONN_Mode	01F0	—																				
		Connection Mode Register																				
		This RAM location reports the connection type and speed established after handshake is completed. The values for this location are the same as those for Config.MODE:																				
		<table border="1"> <thead> <tr> <th>Value</th> <th>Data mode specified</th> </tr> </thead> <tbody> <tr> <td>08</td> <td>V.22bis 2400 bps mode</td> </tr> <tr> <td>09</td> <td>V.22 1200 bps mode</td> </tr> <tr> <td>0B</td> <td>Bell 212A 1200 bps mode</td> </tr> <tr> <td>10</td> <td>V.21 300 bps mode</td> </tr> <tr> <td>11</td> <td>Bell 103 300 bps mode</td> </tr> <tr> <td>13</td> <td>V.23 1200 bps Tx/75 bps Rx mode</td> </tr> <tr> <td>14</td> <td>V.23 75 bps Tx/1200 bps Rx mode</td> </tr> <tr> <td>32</td> <td>V.29 Quick Connect 9600 bps mode</td> </tr> <tr> <td>33</td> <td>V.29 Quick Connect 7200 bps mode</td> </tr> </tbody> </table>	Value	Data mode specified	08	V.22bis 2400 bps mode	09	V.22 1200 bps mode	0B	Bell 212A 1200 bps mode	10	V.21 300 bps mode	11	Bell 103 300 bps mode	13	V.23 1200 bps Tx/75 bps Rx mode	14	V.23 75 bps Tx/1200 bps Rx mode	32	V.29 Quick Connect 9600 bps mode	33	V.29 Quick Connect 7200 bps mode
Value	Data mode specified																					
08	V.22bis 2400 bps mode																					
09	V.22 1200 bps mode																					
0B	Bell 212A 1200 bps mode																					
10	V.21 300 bps mode																					
11	Bell 103 300 bps mode																					
13	V.23 1200 bps Tx/75 bps Rx mode																					
14	V.23 75 bps Tx/1200 bps Rx mode																					
32	V.29 Quick Connect 9600 bps mode																					
33	V.29 Quick Connect 7200 bps mode																					
DTMFh_lev	01A1	−6 dBm																				
		DTMF Transmit Level — High Band																				
DTMFI_lev	01A0	−9 dBm																				
		DTMF Transmit Level — Low Band																				
		These are the transmit levels for the DTMF low band (DTMFI_lev) and DTMF high band (DTMFh_lev) frequencies. The levels are set by the formula:																				
		$\text{DTMFlev} = 10^{(\text{lev})/20} \cdot 32767$																				
		where lev is specified in dBm and less or equal to 0. Change in value takes effect in 0.1 msec. The data pump sets these locations to their default values upon any reset.																				

Table 15. Modem Data Pump Word Definitions

Register & Address (hex)		Default Value	Function and Explanation	
ToneGenA	0191	—	Tone Generator A	
ToneGenB	0196	—	Tone Generator B	
<p>The data pump has two independent tone generators, each simultaneously generating a pure tone with its own transmit level when Config.MODE=1 (transmit tones). The outputs of the tone generators are mixed together. The generated frequencies are set by writing a coefficient to location ToneGenA or ToneGenB. The coefficient is defined as:</p> $\text{coeff}_x = \frac{2\pi \cdot f}{9600} \cdot 4096$ <p>where f is the frequency of the tone to be generated. The transmit levels for tone generators A and B are set in locations DTMFI_lev and DTMFh_lev, respectively. See "Transmitting Tones" for more information including a description of setting the tone transmission levels.</p>				
TxLevel	0185	-10 dBm	Transmit Power Level	
<p>Sets the transmit power level. Use the formula</p> $\text{TxLevel} = 10^{(\text{power})/20} \cdot 2048$ <p>where power is specified in dBm and less than or equal to -6. Change in value takes effect at the end of the baud period.</p>				
Seq3Count	18E	None	Dial Timer Inter-Pulse Count	See Seq1Count
Seq2Count	18D	95 msec	Dial Timer Off Count	See Seq1count
Seq1Count	18C	95 msec	Dial Timer On Count	
<p>Seq1Count, Seq2Count and Seq3Count are timer counts in units of 1/9600 of a second, for DTMF and pulse dialing.</p> <p>For DTMF dialing, Seq1Count is the length of the digit on-time, and Seq2Count is the length of the digit off-time.</p> <p>For pulse dialing, Seq1Count is the length of the break period, Seq2Count is the length of the make period, and Seq3Count is the length of the pause after dialing a digit.</p> <p>The data pump sets these locations to their default values when the host sets Config.MODE=3 (dial).</p>				

INTERFACE RAM DEFINITIONS (Continued)

Table 15. Modem Data Pump Word Definitions

Register & Address (hex)	Default Value	Function and Explanation
Biquad A 0155–015E	—	Biquad A and B Coefficients
Biquad B 015F–0168	—	
		<p>These locations program the frequency range for the biquad tone detectors. The coefficients are in the following order: b2, b1, a3, a2, a1, B2, B1, A3, A2, A1.</p> <p>See the section on Call Progress Monitoring Using BiQuad Tone Detectors for more information.</p>
DTD0– DTD15	0145–0154	Tone Detector Coefficients
		<p>These locations set the tone detector coefficients for the 16 detectors in the system. The coefficients are set by using the following formula:</p> $\text{coeff}_{\text{tone}} = \cos\left(\frac{2\pi \cdot f_{\text{tone}}}{9600}\right) \cdot 32767$ <p>See the section on Tone Detectors for more information.</p>
EQMlev	092	Eye Quality Monitor (EQM)
		<p>Provides a measure of line quality during V.22, V.22bis, or Bell 212A, and is computed as a running average of the mean square error (MSE) of the received point and the decision point. When EQMlev exceeds EQMMaxThresh, Dpc-trl.EQE is set to 1; otherwise, it is set to 0.</p>

Table 15. Modem Data Pump Word Definitions

Register & Address (hex)	Default Value	Function and Explanation
BiQuadOffThresh 052	-42 dBm	<p>Biquad Tone Detectors “off” Point</p> <p>The data pump sets this location to its default value when Config.MODE is set to 2 by the host.</p> <p>This location can be used to set the off point for the Biquad tone detectors. If the power level is below this value, the detector will turn off the detection status bit.</p> <p>Use the following formula to set the threshold:</p> $\text{Threshold} = 10^{(\text{level})/20} \cdot 32767$ <p>where level is in dBm. The data pump sets this location to its default value when the host sets Config.MODE=2 (detect tones).</p>
BiQuadOnThresh 051	-35 dBm	<p>Biquad Tone Detectors “on” Point</p> <p>The data pump sets this location to its default value when Config.MODE is set to 2 by the host.</p> <p>This location can be used to set the on point for the Biquad tone detectors. If the power level is above this value, the detector will turn on the detection status bit.</p> <p>Use the following formula to set the threshold:</p> $\text{Threshold} = 10^{(\text{level})/20} \cdot 32767$ <p>where level is in dBm. The data pump sets this location to its default value when the host sets Config.MODE=2 (detect tones).</p>
DTD0Lev– DTD15Lev	26–35 —	<p>Discrete Tone Detector Levels</p> <p>These locations represent the tone detector levels when in Tone Detect mode (Config.MODE=02H). They may be used by the host to determine which tone is dominant if multiple tones are detected. These locations have no default.</p>
DTDThresh	03 -24 dBm	<p>Discrete Tone Detector Threshold</p> <p>This location programs the threshold for all discrete tone detectors. Any signal whose signal strength is above this threshold will turn on the detection bit for that tone. Any signal below this threshold will turn off the detection bit for that tone. This location can be programmed using the following formula:</p> $\text{Threshold} = 10^{(\text{level})/20} \cdot 32767$ <p>This location must be programmed after Config.MODE is set to detect tone (02H). This is because the data pump will reset this location to its default when Config.MODE is set to tone detect mode. See the section on Tone Detectors for more information.</p>

INTERFACE RAM DEFINITIONS (Continued)

Table 15. Modem Data Pump Word Definitions

Register & Address (hex)	Default Value	Function and Explanation
DTDStatus 00	—	<p>Discrete Tone Detector Status</p> <p>This location contains the status of the tone detectors when in tone detect mode (Config.MODE=02H). Bit 0 contains the status of detector 0, bit 1 the status of detector 1, and so on. This location is only valid when in tone detection mode.</p> <p>The response time of the tone detectors is dependent upon the frequency of the tone being detected and sampling rate of the data pump.</p> <p>When the host sets Config.MODE=0 (standby) or resets the data pump, the data pump writes its part number into this location.</p>

OPERATING NOTES

TRANSMITTING TONES

The data pump has two tone generators, each with their own transmit level. The outputs are mixed together. The frequency of the tones are programmed by writing coefficients to locations ToneGenA and ToneGenB. The transmit levels are programmed by writing values to locations DTMF_lev and DTMFh_lev. If only one tone is to be transmitted, set the other tone generator's transmit level to 0 to disable it.

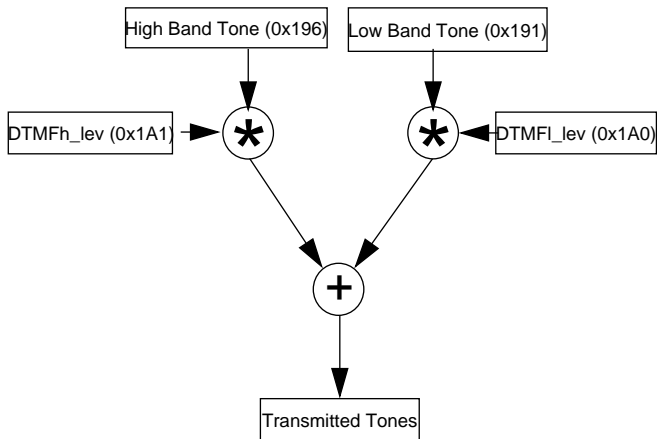

For example, to generate a 2100 Hz Answer Tone for 3.3 seconds at -10dBm:

1. Set location ToneGenA to 015FEH.
2. Set location DTMFI_lev to 0287H.
3. Set location DTMFh_lev to 0, disabling ToneGenB.
4. Set Config.MODE=1 (transmit tone).
5. Wait 3.3 seconds, then set Config.MODE=0 (standby).

STONE DETECTORS

There are 16 tone detectors in the data pump. They are programmed by setting up one word for each tone detectors. There is one global threshold setting for all 16 tone detectors. The address for the tone detectors are as follows:

- Tone Detector Coefficients—0145–0154H (Tone0–Tone15)
- Tone Detector Receive Levels—026H–035H (DTD0lev–DTD15lev)
- Tone Detector Threshold—03H
- Tone Detector Status—00H
- The tone coefficients are calculated as follows:

$$\text{coeff}_{\text{tone}} = \cos\left(\frac{2\pi \cdot f_{\text{tone}}}{9600}\right) \cdot 32767$$

- The default values on reset are:

Tone Detector	Frequency Detected (Hz)
0	697
1	770
2	852
3	941
4	1209
5	1336
6	1477
7	1633
8	1750
9	1800
10	1650
11	2225
12	2250
13	1300
14	2100
15	600

TONE DETECTORS (Continued)

- The threshold is calculated as follows:

$$\text{Threshold} = 10^{(\text{level})/20} \cdot 32767$$

where level is in dBm. The default value for the threshold is -24 dBm. This value is set every time Config.MODE is set up to detect tones. If the user wishes a different value, it should be reloaded *after* Config.MODE is set to detect tones.

To use the tone detectors, perform the following steps:

1. Set up the tone detector coefficients (0145–0154H).
- 2) Set Config.MODE to tone detect mode (02H). Note that this is the same mode for using the Biquad tone detectors. This is because both the Biquad tone detectors and the tone detectors run at the same time. This allows the host to look for individual answer tones as well as call progress tones.
2. Set up the tone detector threshold DTDThresh.
3. Inspect the tone detector status Tone Status for detected tones.
4. When the detection phase is complete, set Config.MODE to standby (00H).

The Detectors are set up as follows:

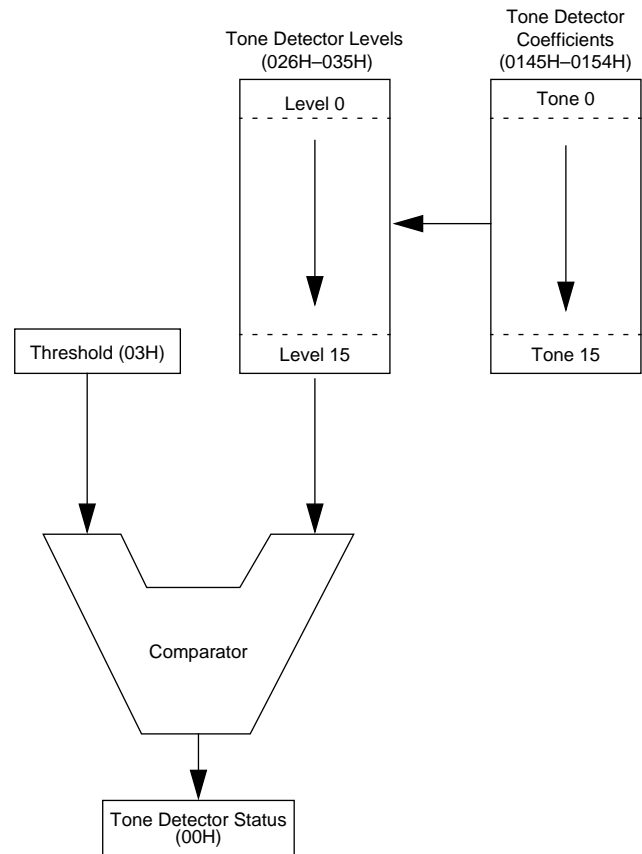

CALL PROGRESS MONITORING USING BIQUAD TONE DETECTORS

The data pump contains two biquad tone detectors that are capable of detecting energy in a frequency band. These detectors are useful for call progress monitoring where the exact frequency of the incoming signal is not known. Each biquad tone detector is composed of two cascaded, independently programmable biquad sections. The order of biquad coefficients in RAM is:

b2, b1, a3, a2, a1, B2, B1, A3, A2, A1

The addresses for the coefficients for the two sections start at 0155H (TONEA) and 015FH (TONEB). The sample rate is 9600 Hz.

The transfer equation for each section of the biquad tone detector is of the form:

$$H_n = \frac{2(a_1 + a_2Z^{-1} + a_3Z^{-2})}{(1 - 2b_1Z^{-1} - 2b_2Z^{-2})}$$

There are two threshold settings affecting both biquad tone detectors. The locations BiQuadOffThresh and BiQuadOnThresh define the on and off hysteresis points:

- BiQuadOffThresh–052H–Off point.
- BiQuadOnThresh–051H–On point.

Use the following formula to set the thresholds:

$$\text{Threshold} = 10^{(\text{level})/20} \cdot 32767$$

where level is in dBm. The default values are –35 dBm (BiQuadOnThresh) and –42dBm (BiQuadOffThresh).

The biquad tone detector status is contained in ToneStatus.TONEA and ToneStatus.TONEB. The response time of the biquad tone detectors depends on the coefficients and the input signal frequency.

The biquad tone detectors can be cascaded to form one tone detector with 4 biquad sections (an 8th order IIR filter) by setting ToneStatus.CASCADE. In this case ToneStatus.TONEA contains the status of the cascaded tone detector, and ToneStatus.SQRDIS controls whether the output of biquad tone detector B is squared before being input to biquad tone detector A.

The default settings for the biquad tone detector coefficients are shown in the tables below, where the first row is TONEA and the second row is TONEB. The data pump sets the biquad tone detector coefficients to their default settings upon any reset.

Biquad Section 1 Coefficients (Hex)

Band (Hz)	b2	b1	a3	a2	a1
245–650	C63E	6FE1	F8EA	0000	0716
360–440	C7CD	7438	01AA	FEBC	01AA

Biquad Section 2 Coefficients (Hex)

Band (Hz)	B2	B1	A3	A2	A1
245–650	C774	7601	0716	F5FB	0716
360–440	C148	7A66	FF5C	0000	00A4

To use the Biquad tone detectors to do Call Progress Monitoring, do the following:

1. Set the coefficients. Coefficients which are changed remain valid until the next reset.
2. Set Config.MODE=2 (detect tones). The biquad tone detectors and the discrete tone detectors operate simultaneously to allow the host to look for call progress tones and individual answer tones at the same time.
3. Set the BiquadOnThresh and BiquadOffThresh values.
4. If the two biquad tone detectors are to be cascaded, set ToneStatus.CASCADE=1. Then if desired, set ToneStatus.SQRDIS=1 to disable the squarer when the tone detectors are cascaded.
5. Inspect ToneStatus.TONEA and ToneStatus.TONEB for the detection status. If ToneStatus.CASCADE is set, only inspect ToneStatus.TONEA.
6. Time the on time and the off time of the tone(s). This gives you the cadence, which is used to identify the type of call progress tone detected. For example, 0.5 second on, 0.5 second off is usually a BUSY tone.
7. After call progress monitoring is complete, set Config.MODE=0 (standby).

DIALING

The data pump may be programmed to dial using either DTMF tones, or make/break pulses. By default, the data pump is configured for tone (DTMF) dialing.

Tone Dialing

Tone dialing may be either continuous or timed. Continuous dialing generates the desired tone until the host specifically shuts it off. Timed dialing allows the host to specify the on/off timing of the digit dialed.

This example assumes the host controls the data pump's RTS through Reg4.RTSP. To perform tone dialing:

1. Set Reg4.RTSP=0, ToneStatus.TIMEDIAL=1 for timed dialing or=0 for continuous dialing. Then set Config.MODE=3 (dial). Then, if timed dialing is required, set the timer locations Seq1Count and Seq2Count.
2. Control the twist by setting locations DTMFh_lev and DTMFl_lev to specify the transmit levels of the high tone and the low tone respectively.
3. Set up the digit to be dialed in ToneStatus.DIGIT bits 0–3 according to the following table:

Digit	Value
0	0
1	1
2	2
3	3
4	4
5	5
6	6
7	7
8	8
9	9
*	10
#	11
A	12
B	13
C	14
D	15

4. For continuous operation, set Reg4.RTSP=1 to start transmitting the DTMF tone and=0 to stop.
5. For timed operation, set Reg4.RTSP=1 to dial the digit. The data pump sets Reg5.DPBUSY=1 while it dials the digit. Set Reg4.RTSP=0 after the digit has been dialed. The data pump sets Reg5.DPBUSY=0 when the dial sequence is completed.
6. To dial additional digits, repeat the procedure starting at step 3.
7. When dialing is complete, set Config.MODE=0 (standby).

Pulse Dialing

Pulse dialing is very similar to timed dialing, with the exception that the "tone" generated is a cadence of pulses output on the \overline{OH} pin and mirrored in RAM location MStatus.OFFHOOK. To implement pulse dialing, follow the instructions for timed tone dialing, except:

1. Select pulse instead of tone dial mode by setting location ToneStatus. TONEDIAL=0 ToneStatus.TIMEDIAL has no effect. Pulse dialing is always timed.
2. After setting Config.MODE=3 (dial), set Seq1Count and Seq2Count and Seq3Count to the desired break and make times, and the pause after each digit is dialed. For North American applications requiring a 100 msec cadence, a 39%/61% make/break ratio, and a 0.75 second pause, set locations Seq1Count=024AH, Seq2Count=0176H, and Seq3Count=01C20H.

MANUAL HANDSHAKE PROCEDURES

The V.22bis data pump software allows the host to control every aspect of the handshake procedure. The host instructs the data pump which signal to send at which time. The data pump sets status bits when it receives signals from the remote modem.

The host begins a manual handshake by setting Config.MCUCTRL=1 to prevent the data pump from transmitting its own handshake signals.

The host monitors the receive signal status bits in location Trnctrl and transmits its own responding signals by setting Trnctrl.TXCTRL to the following values:

Trnctrl Value	Signal Transmitted
0	Silence
1	1200 bps Unscrambled Binary 1
2	S1
3	1200 bps Scrambled Binary 1
4	2400 bps Scrambled Binary 1
5	1200 bps data mode or FSK
6	2400 bps data mode
7	2225 Hz tone

In the following section certain acronyms shall be used to denote the various V.22bis handshake signals. These are:

Name	Meaning
USB1	Unscrambled Binary 1
SB1	Scrambled Binary 1
S1	S1 Signal

Originating modem

- Take the telephone line off-hook and dial.
- Program the discrete tone detectors and the biquad tone detectors for answer tones (2100 Hz) and call progress tones (200–600 Hz). Look for the answer tone and also call progress tones (such as busy tones, ring back and so on).
- Upon receiving the 2100 Hz answer tone, set Config=4409H (V.22, V.22bis originate, manual handshake).
- Wait for Trnctrl.USB1DET=1 (USB1 detected) continuously for 155 msec.
- Wait for 456 msec.
- Set Trnctrl.TXCTRL=2 (transmit S1 signal) for 100 msec.
- Set Trnctrl.TXCTRL=3 (transmit SB1) and inspect Trnctrl.S1DET and Trnctrl.SB1DET repeatedly for either a received S1 signal or SB1. If SB1 is received for 270 msec, proceed to step 11. If S1 is received, wait for the S1 to end. Then wait for an additional 450 msec.
- Set Trnctrl.V22BIS=1 (force a 16 way receive decision). Wait for 150 msec.
- Set Trnctrl.TXCTRL=4 (transmit SB1 at 2400 bps). Wait for 200 msec.
- Set Trnctrl.TXCTRL=6 (2400 bps data mode). Data is now being transmitted and received at 2400 bps.
- In step 7, if SB1 is detected instead of the S1 signal, wait for 765 msec, then set Trnctrl.TXCTRL=5 (1200 bps data mode). Data is now being transmitted and received at 1200 bps.

Answering Modem

- Upon a ring signal or a command from the host, take the phone off-hook and transmit silence for 1.8 to 2.5 seconds.
- If desired, use the tone generators to transmit a 2100 Hz tone for 2.6 to 4 seconds. This is the V.25 answer tone.
- Set Config.MODE=0 (standby) and transmit silence for 75 msec.
- Set Config=8 (answer mode, manual handshake). After setting Config, the host should be prepared to receive data from the remote modem. The data pump holds the received data to marks (i.e., receives nothing) until the modem is able to receive data from the remote modem.
- Set Trnctrl.TXCTRL=1 (transmit USB1).
- Inspect Trnctrl.S1DET and Trnctrl.SB1DET repeatedly for either a received S1 signal or SB1. If SB1 is received continuously for 270 msec, proceed to step 12. If an S1 signal is received (Trnctrl.S1DET=1) wait for the S1 to end.
- Set Trnctrl.TXCTRL=2 (transmit S1 signal) for 100 msec.
- Set Trnctrl.TXCTRL=3 (transmit SB1) for 350 msec.
- Set Trnctrl.V22BIS=1 (force 16 way receive decisions). Wait for 150 msec.

MANUAL HANDSHAKE PROCEDURES (Continued)

10. Set Trnctrl.TXCTRL=4 (transmit SB1 at 2400 bps). Wait for 200 msec.
11. Set Trnctrl.TXCTRL=6 (2400 bps data mode). Data is now being transmitted and received at 2400 bps.
12. If in step 6., SB1 is received instead of an S1 signal, set Trnctrl.TXCTRL=3 (transmit SB1) for 765 msec, then set Trnctrl.TXCTRL=5 (1200 bps data mode). Data is now being transmitted and received at 1200 bps.

MAKING A V.22BIS CONNECTION

In the following example, all timing is performed by the host.

Originating Modem

1. Take the telephone line off-hook and dial.
2. Program the discrete tone detectors and the biquad tone detectors for answer tones (2100 Hz) and call progress tones (200–600 Hz). Look for the answer tone and call progress tones (busy tones, ring back, etc.)
3. Upon receiving the 2100 Hz answer tone, set Config=4008H (V.22bis originate). After setting Config, the host should be prepared to receive data from the remote modem. The data pump holds the received data to marks (i.e., receives nothing) until the modem is able to receive data from the remote modem.
4. When the data pump establishes a V.22bis connection and is ready to transmit data to the remote modem, it sets Reg5.CDET=1. Data may now be transmitted or received between the modems.

Answering Modem

1. Upon a ring signal or command from the terminal, take the phone off-hook and transmit silence for 1.8–2.5 seconds.

2. If desired, use the tone generators to transmit a 2100 Hz tone for 2.6–4 seconds. This is the V.25 answer tone.
3. Set Config.MODE=0 (standby) and transmit silence for 75 msec.
4. Set Config=8 (V.22bis answer). After setting Config, the host should be prepared to receive data from the remote modem. The data pump holds the received data to marks (i.e., receives nothing) until the modem is able to receive data from the remote modem.
5. When the data pump establishes a V.22bis connection and is ready to transmit data to the remote modem, it sets Reg5.CDET=1. Data may now be transmitted or received between the modems.

Important notes

- a. The data pump sets Reg5.CDET=0 during carrier dropouts, retrains, and when the remote modem hangs up the telephone line. Depending on the data mode, the host may use Reg5.CDET, Reg5.RTRND, Dpctrl.EQE, EQMlev and EQMMaxThresh to determine when the remote modem has initiated a retrain, or has hung up the telephone line.
- b. During 2400 bps V.22bis data mode, the host may use Dpctrl.EQE and EQMMaxThresh or EQMlev to determine when to initiate a retrain (see MStatus.RETRAIN) to improve the quality of the connection.

USING HDLC

The data pump includes HDLC firmware operating in all data modes. The HDLC firmware performs all the necessary operations to frame host-supplied data into HDLC format, including automatic opening and closing flag generation, zero insertion and deletion, flag and abort detection, and CRC checksum computation and checking.

HDLC Operation

During HDLC operation the data pump frames host-supplied asynchronous data into a synchronous data stream in the transmitter, and extracts the same asynchronous data from the received synchronous data stream in the receiver. The inclusion of 16-bit cyclic redundancy check (CRC) information in the frames allows the receiving host to check whether the data has been correctly received.

HDLC data is sent in frames. A frame consists of a number of bytes, each composed of 8 data bits. A frame contains an opening flag, frame data bytes, two CRC checksum bytes and a closing flag, in this order. Opening flags and closing flags indicate the start and the end of a frame, respectively.

A flag, byte value 07EH, is one of two HDLC control symbols. The other is an abort, which is any sequence of consecutive binary 1s more than six bits long. If the frames do not use the bandwidth of the data mode (for example, when there is no host data to transmit), the modem fills the remaining bandwidth by sending flags between frames.

Frame data bytes for transmission are supplied by the host to the data pump's DATAP register. These bytes are modified by the data pump to ensure that no more than five consecutive binary 1 bits are sent. To do this, the transmitting modem inserts a single 0 bit after every five consecutive binary 1 bits in the host supplied data. This zero insertion process allows the receiving modem's data pump to distinguish between frame data, flags and aborts. The receiving modem's data pump uses a zero deletion process to remove each inserted 0 bit before returning the data to the receiving modem's host.

When a frame is to be closed, the frame's two CRC checksum bytes are sent immediately following the frame data. The CRC checksum is computed without the inserted zeroes. The frame's closing flag is transmitted following the CRC. This flag may also serve as the opening flag of the next frame, saving bandwidth.

Enabling HDLC Operation

The data pump's HDLC firmware is disabled upon power-up and any reset, and can be enabled only in parallel mode (Reg4.TPDM=1). To enable HDLC, set Bufctrl.HDLC to 1, and bits 8..15 of Bufctrl to 0 prior to beginning data mode operation. The host should also read register DATAP just before starting data mode to clear DATAP.

These examples demonstrate the use of the data pump in parallel mode to transmit and receive HDLC data frames. The examples assume that the data pump has just been put in data mode, and HDLC operation is enabled. The data to be sent or received is the sequence of N bytes {Byte1..ByteN}, where Byte1 is sent (or received) first.

Transmitting

1. When Reg5.TXI=1, write Byte1 to DATAP. Repeat this step for each byte to be transmitted. If Reg4.TXIE=1, the data pump generates an interrupt when it is ready to transmit the next byte, i.e. when it sets Reg5.TXI=1.
2. When the last byte, ByteN, has been sent, wait for the data pump to set Reg7.TEND=1. This indicates the data pump has closed the current frame. The data pump now computes and transmits the CRC checksum and closing flag for the frame. The data pump does not set Reg7.TEND=1 until at least 8 bit times after it has set Reg4.TXI=1 indicating the data pump is ready to transmit another data byte. To transmit another frame, repeat steps 1-2.
3. When the data pump begins sending the frame's closing flag, it sets Reg7.TEND=0. Transmission of the frame is complete 8 bit times after the data pump sets Reg7.TEND=0.

Receiving

1. Prepare to receive a new frame.
2. When Reg5.RXI=1 the data pump has received a byte. First read register Reg7, then DATAP. Register Reg7 is read first because the data pump may change it any time after DATAP is read. If Reg4.RXIE=1, the data pump generates an interrupt when it sets Reg5.RXI=1.
3. Act on the value of Reg7 read in step 2 as follows: (a) If RXERROR=0 and EOF=0 the DATAP value read in step 2 is an HDLC frame byte. Repeat step 2 to receive all remaining frame bytes. (b) If RXERROR=0 and EOF=1 an HDLC frame with a correct checksum has been received. If bytes Byte1..ByteN+3 have been read, with ByteN+3 being the DATAP value just read, then the two previous bytes, ByteN+1 and ByteN+2, are the frame checksum bytes, and the remaining bytes, Byte1..ByteN, are the frame data bytes. Continue from step 1 to receive the next frame. If RXERROR=1 discard any received frame bytes and continue from step 1 to receive the next frame. (c) If DATAP was 07EH, an HDLC abort sequence was received. If DATAP was 07EH, an HDLC frame with an incorrect checksum was received.

GETTING THE DATA PUMP FIRMWARE VERSION NUMBER AND PART NUMBER

The data pump code version can be obtained any time RAM location Config.MODE is set to 0. The data pump will write the part number to data pump RAM location 0 and the code version number to the DATAP register. To obtain the version and part number from the data pump, the following steps must be performed:

1. Set Config.MODE to 0 (standby), then read location Config to give the data pump enough time to begin standby operation.
2. Read the DATAP register. This will return the code release version number (an 8 bit value, e.g., 030H indicates version 30).
3. Read RAM location 0. This will return the part number (e.g., 02922H for a Z02922 part).

SLEEP MODE

The data pump incorporates a low power sleep mode. In this mode the data pump clock is shut down, effectively stopping the part. To enter sleep mode, the controller can set Config to mode 7. To exit sleep mode, the controller

can either reset the data pump (asserting the RESET signal) or write any value to the DATAP register. The host should then wait at least 2 msec before accessing the data pump registers.

V.29 QUICK CONNECT HANDSHAKE

The data pump provides a V.29 Quick Connect mode. This is a half duplex synchronous 9600 bps modulation scheme allowing the host to change the direction of the data flow quickly. When used with a suitable host data transfer protocol, it can provide a fast pseudo full duplex channel.

The data pump characterizes the telephone line connection by performing a long training sequence before the first exchange of data in each direction. Subsequent training sequences are quicker because they make use of characteristics determined during the last long training sequence.

V.29 Quick Connect is a half duplex mode. Only one modem transmits a carrier at any given point in time. Whenever training is performed, both modems must be set to perform the same type of train, i.e., long or short.

This example assumes that a telephone connection has been established, that the host is using parallel mode, and that the host controls the data pump's RTS through Reg4.RTSP. The description of register Reg4.RTSP explains the host's options for controlling the data pump's RTS signal.

To Transmit

1. Before transmitting for the first time in each direction (i.e., in each modem) after a telephone connection has been established, set Dpctrl.TXSTRN=0 for a long train. For subsequent trains, set Dpctrl.TXSTRN=1 for a short train. Then set Config.MODE=020H (9600 bps V.29) or 021H (7200 bps V.29). Then set Reg4.RTSP=1 to cause the data pump to begin transmission.

2. Set Config.ECHOPRTEN and Config.ECHOPRTLEN at the same time as Config.MODE to transmit an echo protect tone if desired.
3. Inspect Reg5.CDET. When Reg5.CDET=1 the host may begin transmitting data. If parallel mode transmit interrupts are desired, set Reg5.TXIE=1.
4. When desired, set Reg4.RTSP=0 to end transmission. Wait for Reg5.DPBUSY=0 to indicate the data pump has completed transmission before beginning receiving or hanging up the telephone line.

To Receive

1. Before receiving for the first time in each direction (i.e., in each modem) after a telephone connection has been established, set Dpctrl.RXSTRN=0. Then set Config.MODE=020H (9600 bps V.29) or 021H (7200 bps V.29). Set Reg4.RTSP=0 to cause the data pump to begin reception.
2. Inspect Reg5.CDET. When Reg5.CDET=1 the host may begin transmitting data. If parallel mode transmit interrupts are desired, set Reg5.TXIE=1.
3. Receive data for at least 50 msec, then set Dpctrl.RXSTRN=1 to cause the data pump to receive a shortened train sequence for subsequent trains. Do not set Dpctrl.RXSTRN=0 between trains or another long train must be executed even if Dpctrl.RXSTRN is restored to 1 before the next train.

4. When the data pump loses carrier, it sets Reg5.CDET=0. Wait for Reg5.CDET continuously for at least 50 msec before assuming reception has

ended. Once reception has ended, the host may switch the data pump to begin transmitting, or hang up the telephone line.

TYPICAL PERFORMANCE DATA

The Bit Error Rate (BER) and Block Error Rate (BLER) curves in Figure 10 and 11 represent typical performance over a variety of signal to noise conditions (SNR). Note that modems will usually exhibit lower bit error rates receiving in the low band as opposed to the high band. One analog link was made, after which the Adaptive Equalizer (AEQ) was frozen. The noise level was then increased without making new links. These tests were conducted using a Consultronics TCS500 Telephone Line Simulator

and a Hewlett Packard 4951B protocol analyzer/BERT tester, under the following conditions:

Line Simulation	Flat
Transmit Level	-10 dBm
Receive Level	-16.0 dBm
Data Transmitted	511 pseudo-random pattern
Number of Bits Sent	1,000,000
Number of Blocks Sent	1,000
Bits per Block	1,000
AEQ	Frozen after link establishment
Noise Calibration	C-message

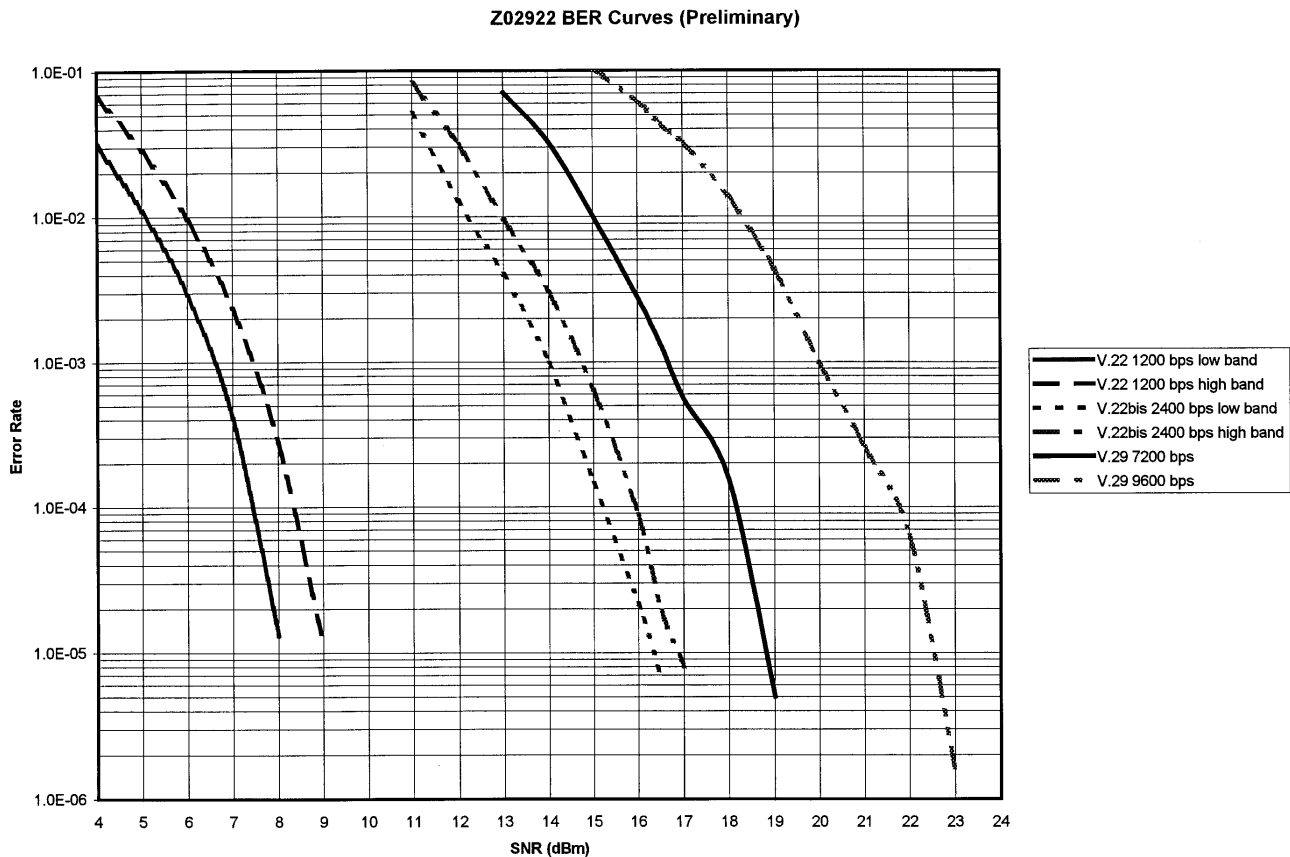

Figure 9. Typical Performance Data

TYPICAL PERFORMANCE DATA (Continued)

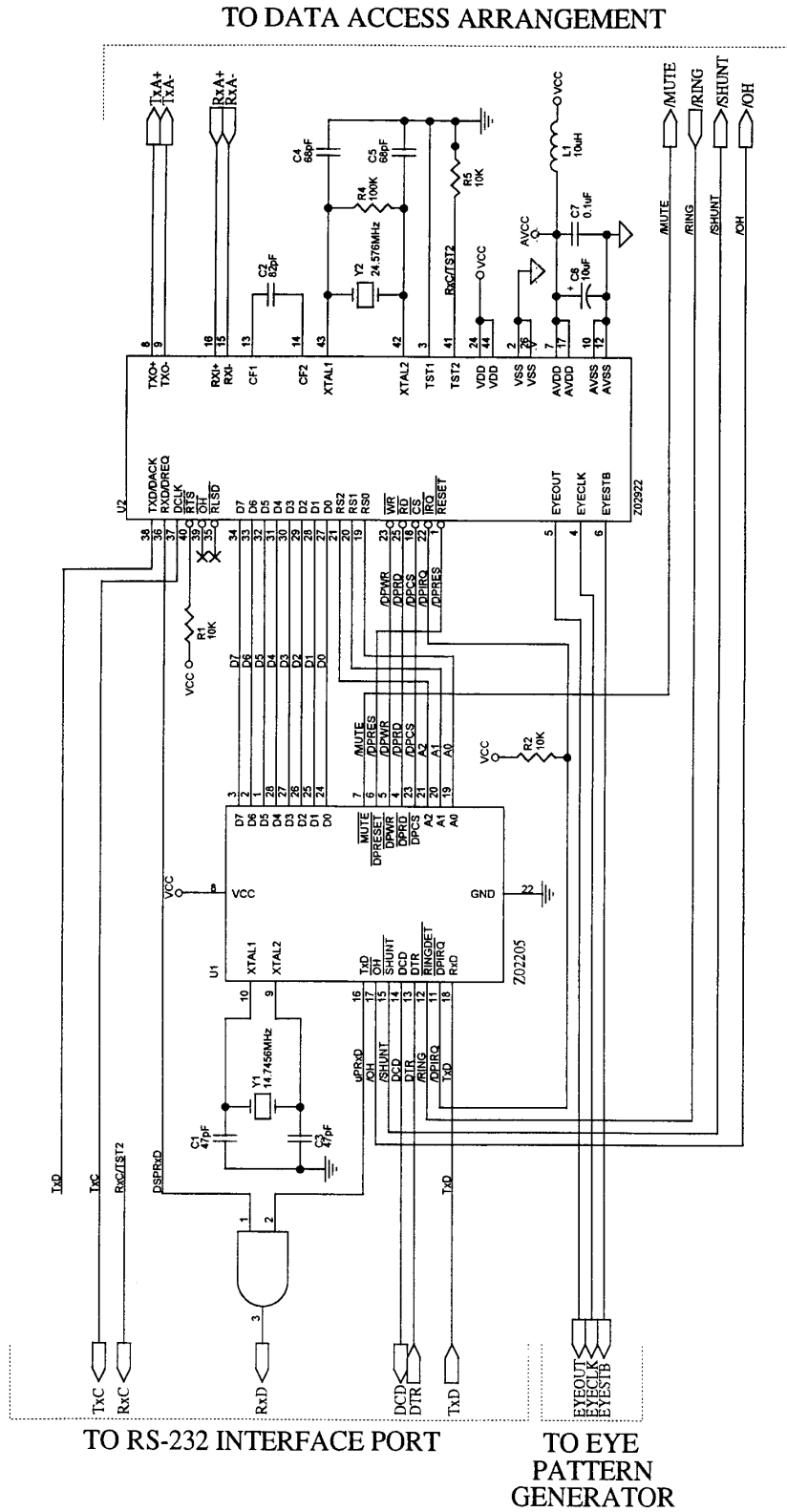

Figure 10. Typical Modem Using Z02922

EXAMPLE DAA

Figure 11 shows an example DAA configuration for North America. Isolation transformer T1 couples the primary (line) and secondary (modem) sides, while providing high voltage isolation. This "wet" transformer (allowing DC current) simplifies the circuit and reduces the cost of the DAA.

On the Secondary side, the transmit (TxA+ and TxA-) and receive (RxA+ and RxA-) are combined in the 4-wire to 2-wire hybrid circuit. This hybrid can be either passive or active. The more complex active hybrid allows operation to lower signal levels, since it cancels out most of the transmit signal from the receive signal.

On the Primary side, the off-hook relay switches the phone line between a local handset (PHONE) or the modem. The ring detect circuit consists of DC blocking capacitor C4, current limiting resistor R2, zener diodes CR3 and CR4, optocoupler U3 and its reverse protection diode D3. Protection elements RV1, F1, C1, and C2 (and transformer T1's isolation) will provide higher voltage capability for approval in some foreign markets. C1 and C2, for example, may need to be replaced by Metal Oxide Varistors (MOVs) or Gas Discharge Tubes (GDTs). The shunt relay reduces the DAA impedance during pulse dialing. This is required for certain country approvals.

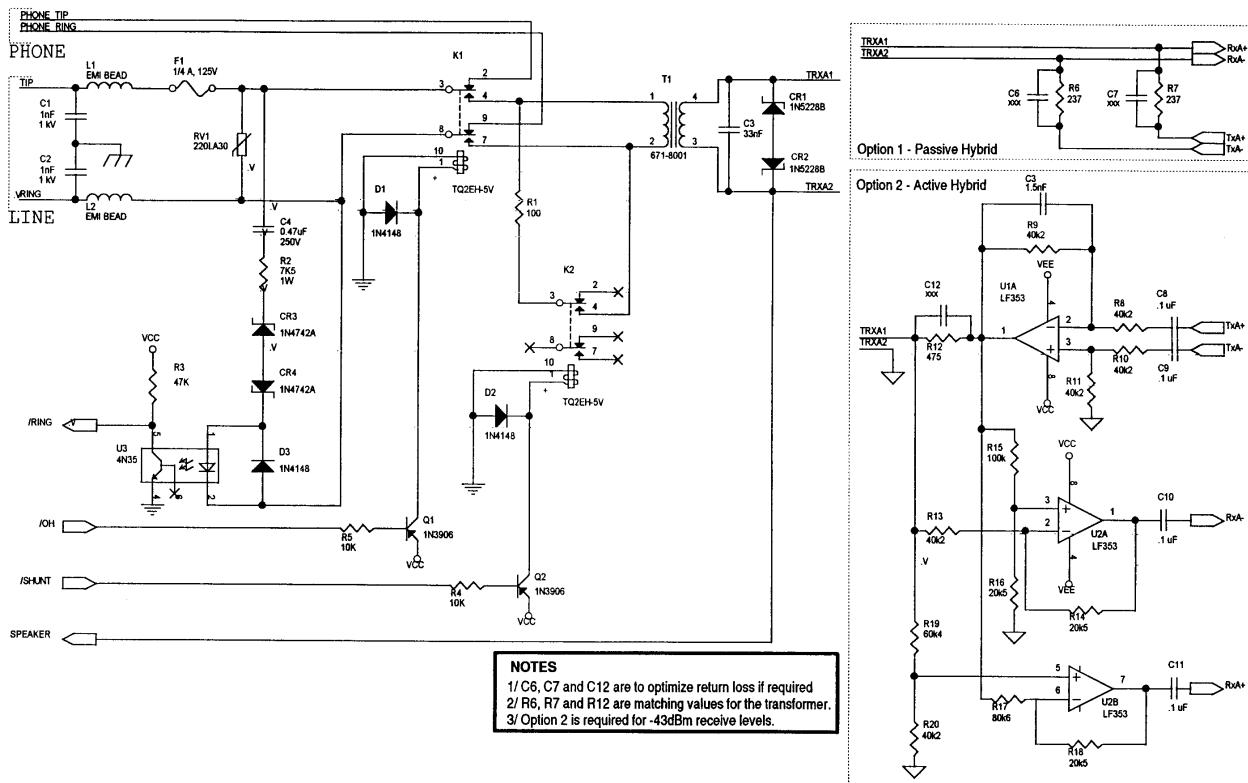

Figure 11. Example DAA

EYE PATTERN CIRCUIT

Figure 12 is the eye pattern circuitry used on the Z0220100ZCO modem evaluation board, and can be used with modem components such as the Zilog Z02201 and Z02922 that have an eye pattern interface. The Z02201 Eye Pattern port consists of 3 signals:

Data (EYEOUT): The most significant and least significant bytes of this 16 bit word are the X and Y coordinates respectively for the eye pattern display. Each byte is most significant bit first.

Clock (EYECLK): Data is set on the rising edge of the EYECLK, and should be read on the falling edge.

Strobe ($\overline{\text{EYESTB}}$): This signal is active low when the data is valid.

Data is shifted through a pair of 8 bit serial-in parallel-out shift registers (74HC594) in response to the falling edge of EYECLK, then latched into a pair of 8 bit DACs on the rising edge of EYESTB. The output of these DACs can be viewed on an oscilloscope in X-Y mode to see the received signal quality.

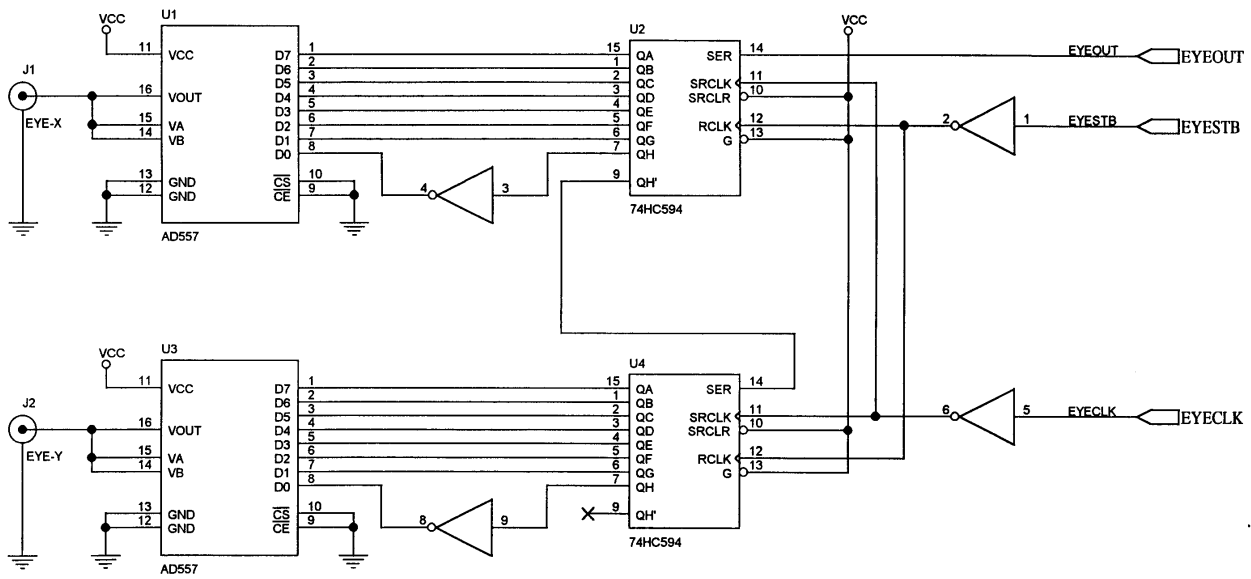

Figure 12. Eye Pattern Circuit

PACKAGE INFORMATION

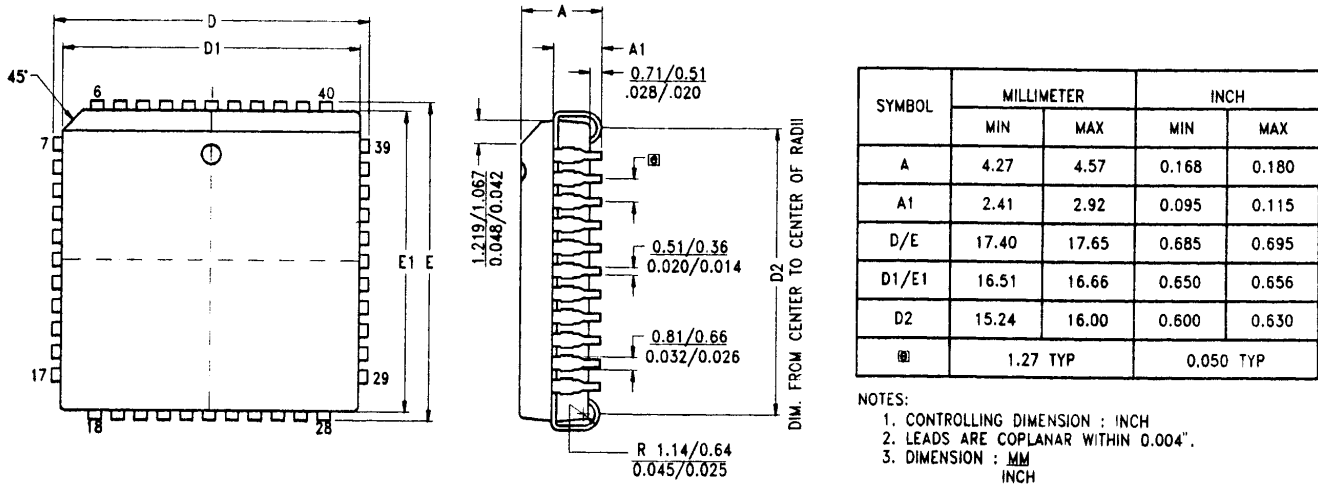

Figure 13. 44-Lead PLCC Package Diagram

ORDERING INFORMATION

Z02922
12 MHz
44-Pin PLCC
Z0292212VSC
Z0292212VEC

For fast results, contact your local Zilog sales office for assistance in ordering the part desired.

CODES

Speed

12=12 MHz

Package

V=Plastic Leaded Chip Carrier

Temperature

S=0°C to +70°C

E=-40°C to +85°C

Environmental

C=Plastic Standard

Example

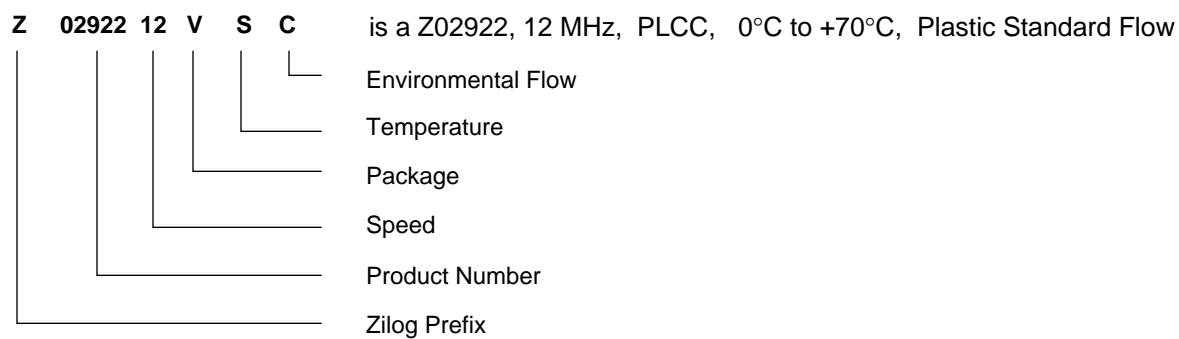

© 1998 by Zilog, Inc. All rights reserved. No part of this document may be copied or reproduced in any form or by any means without the prior written consent of Zilog, Inc. The information in this document is subject to change without notice. Devices sold by Zilog, Inc. are covered by warranty and patent indemnification provisions appearing in Zilog, Inc. Terms and Conditions of Sale only. Zilog, Inc. makes no warranty, express, statutory, implied or by description, regarding the information set forth herein or regarding the freedom of the described devices from intellectual property infringement. Zilog, Inc. makes no warranty of merchantability or fitness for any purpose. Zilog, Inc. shall not be responsible for any errors that may appear in this document. Zilog, Inc. makes no commitment to update or keep current the information contained in this document.

Zilog's products are not authorized for use as critical components in life support devices or systems unless a specific written agreement pertaining to such intended use is executed between the customer and Zilog prior to use. Life support devices or systems are those which are intended for surgical implantation into the body, or which sustains life whose failure to perform, when properly used in accordance with instructions for use provided in the labeling, can be reasonably expected to result in significant injury to the user.

Zilog, Inc. 210 East Hacienda Ave.
Campbell, CA 95008-6600
Telephone (408) 370-8000
FAX 408 370-8056
Internet: <http://www.zilog.com>

