

SN54S135, SN74S135 QUADRUPLE EXCLUSIVE-OR/NOR GATES

DECEMBER 1972—REVISED MARCH 1988

- Fully Compatible with Most TTL and TTL MSI Circuits
- Fully Schottky Clamping Reduces Delay Times . . . 8 ns Typical
- Can Operate as Exclusive-OR Gate (C Input Low) or as Exclusive-NOR Gate (C Input High)

SN54S135 . . . J OR W PACKAGE
SN74S135 . . . D OR N PACKAGE

(TOP VIEW)

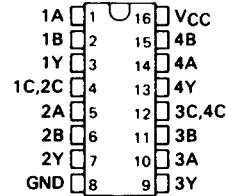

SN54S135 . . . FK PACKAGE

(TOP VIEW)

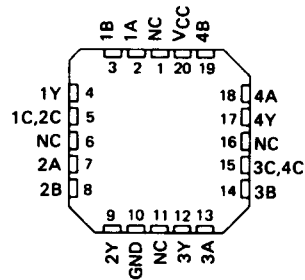

NC - No internal connection

FUNCTION TABLE			
INPUTS			OUTPUT
A	B	C	Y
L	L	L	L
L	H	L	H
H	L	L	H
H	H	L	L
L	L	H	H
L	H	H	L
H	L	H	L
H	H	H	H

H = high level, L = low level

logic diagram (one half)

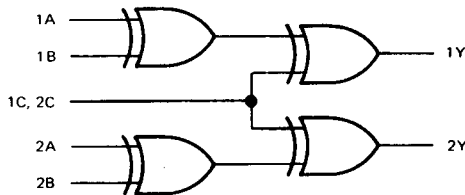

positive logic

$$Y = A \oplus B \oplus C = \overline{A} \overline{B} C + \overline{A} B \overline{C} + A \overline{B} \overline{C} + ABC$$

logic symbol[†]

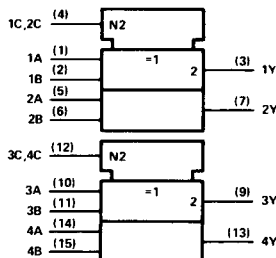

[†]This symbol is in accordance with ANSI/IEEE Std. 91-1984 and IEC Publication 617-12. Pin numbers are for D, J, N, and W packages.

schematics of inputs and outputs

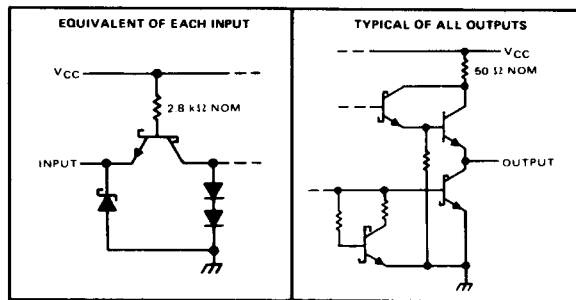

Resistor values shown are nominal.

2

TTL Devices

PRODUCTION DATA documents contain information current as of publication date. Products conform to specifications per the terms of Texas Instruments standard warranty. Production processing does not necessarily include testing of all parameters.

TEXAS
INSTRUMENTS

POST OFFICE BOX 655012 • DALLAS, TEXAS 75265

2-415

SN54S135, SN74S135 QUADRUPLE EXCLUSIVE-OR/NOR GATES

absolute maximum ratings over operating free-air temperature range (unless otherwise noted)

Supply voltage, V_{CC} (see Note 1)	7 V
Input voltage	5.5 V
Operating free-air temperature range: SN54S135	-55°C to 125°C
SN74S135	0°C to 70°C
Storage temperature range	-65°C to 150°C

NOTE 1: Voltage values are with respect to network ground terminal.

recommended operating conditions

	SN54S135			SN74S135			UNIT
	MIN	NOM	MAX	MIN	NOM	MAX	
Supply voltage, V_{CC}	4.5	5	5.5	4.75	5	5.25	V
High-level output current, I_{OH}			-1			-1	mA
Low-level output current, I_{OL}			20			20	mA
Operating free-air temperature, T_A	-55		125	0		70	°C

electrical characteristics over recommended operating free-air temperature range (unless otherwise noted)

PARAMETER	TEST CONDITIONS†	MIN	TYP‡	MAX	UNIT	
V_{IH} High-level input voltage		2			V	
V_{IL} Low-level input voltage				0.8	V	
V_{IK} input clamp voltage				-1.2	V	
V_{OH} High-level output voltage	$V_{CC} = \text{MIN}, I_I = -18 \text{ mA}$ $V_{CC} = \text{MIN}, V_{IH} = 2 \text{ V},$ $V_{IL} = 0.8 \text{ V}, I_{OH} = -1 \text{ mA}$	SN54S'	2.5 3.4		V	
V_{OL} Low-level output voltage	$V_{CC} = \text{MIN}, V_{IH} = 2 \text{ V},$ $V_{IL} = 0.8 \text{ V}, I_{OL} = 20 \text{ mA}$			0.5	V	
I_I Input current at maximum input voltage	$V_{CC} = \text{MAX}, V_I = 5.5 \text{ V}$			1	mA	
I_{IH} High-level input current	$V_{CC} = \text{MAX}, V_I = 2.7 \text{ V}$			50	µA	
I_{IL} Low-level input current	$V_{CC} = \text{MAX}, V_I = 0.5 \text{ V}$			-2	mA	
I_{OS} Short-circuit output current§	$V_{CC} = \text{MAX}$			-40	-100	mA
I_{CC} Supply current	$V_{CC} = \text{MAX}, \text{ See Note 2}$			65	99	mA

† For conditions shown as MIN or MAX, use the appropriate value specified under recommended operating conditions for the applicable type.

‡ All typical values are at $V_{CC} = 5 \text{ V}, T_A = 25^\circ \text{C}$.

§ Not more than one output should be shorted at a time and duration of the short circuit should not exceed one second.

NOTE 2: I_{CC} is measured with the inputs grounded and the outputs open.

switching characteristics, $V_{CC} = 5 \text{ V}, T_A = 25^\circ \text{C}$

PARAMETER	FROM (INPUT)	TEST CONDITIONS	MIN	TYP	MAX	UNIT
t_{PLH}	A or B	B or A = L, C = L	8.5	13	ns	
t_{PHL}			11	15		
t_{PLH}	A or B	B or A = H, C = L	8	12	ns	
t_{PHL}			9	13.5		
t_{PLH}	A or B	B or A = L, C = H	10	15	ns	
t_{PHL}			6.5	10		
t_{PLH}	A or B	B or A = H, C = H	8.5	12	ns	
t_{PHL}			7	13		
t_{PLH}	C	A = B	8	12	ns	
t_{PHL}			9.5	14.5		
t_{PLH}	C	A ≠ B	7.5	11.5	ns	
t_{PHL}			8	12		

NOTE 3: Load circuits and voltage waveforms are shown in Section 1.