

**Rockwell**

## RC144ACF and RC144ATF Integrated High Speed Data/Fax/Voice Single Device Modem for Desktop Applications

### INTRODUCTION

The Rockwell RC144ACF and RC144ATF integrated data/fax/voice modem device supports high speed data and high speed fax modem operation in the US or worldwide over a dial-up telephone line. (Table 1 lists the models).

Packaged in a single 68-pin PLCC device, this modem is optimized for desktop applications and provides maximum integration and functionality with minimum supporting component design.

The modem operates at line speeds up to 14400 bps and supports fax Group 3 send and receive and T.30 protocol.

RC144ATF models require no external RAM or ROM. Models are available to support either a parallel 16550A UART-compatible interface host or a serial EIA/TIA-232-E logic-compatible DTE interface.

RC144ACF models perform error correction and data compression (ECC) in the modem using 32k bytes of external RAM. ECC increases data throughput typically by a factor of four.

RC144ATF models support ECC performed by the host CPU and communications software for Windows using the enhanced Rockwell Windows Protocol Interface (RPI+™) and WinRPI host software module.

RC144ATFW and RC144ACFW models use an external EPROM to support single country (8k bytes) or multiple countries (128k bytes).

In voice mode, enhanced ADPCM coding and decoding supports efficient digital storage of voice using 2-bit or 4-bit compression and decompression at 7200 bps. Coder silence deletion and decoder silence interpolation is available to significantly increase compression rates.

Voice models operating with the parallel host bus support business audio and the Integrated Communications System (ICS) program. These models support applications such as digital answering machine, voice annotation, audio file play/record, and text-to-speech conversion.

In voice/business audio mode and in data modem modes, the modem supports data throughput in excess of 176 kbps utilizing the Rockwell High Speed Interface (RHSI). RHSI allows slower PCs such as 16 MHz 386-based computers to sustain data rates of 115.2 kbps and higher.

AccelerATOR kits and reference designs are available to minimize application design time and costs.

### FEATURES

- Data modem throughput up to 57.6 kbps
  - V.32 bis, V.32, V.22 bis, V.22A/B, V.23, and V.21; Bell 212A and 103
- RC144ACF performs ECC in the modem
  - V.42 LAPM and MNP 2-4 error correction
  - V.42 bis and MNP 5 data compression
  - MNP 10 data throughput enhancement
- RC144ATF supports ECC performed in the host
  - V.42 LAPM and MNP 2-4 error correction
  - V.42 bis and MNP 5 data compression
- Enhanced Rockwell Protocol Interface (RPI+) supported by WinRPI host software module
- Backward compatible with software that supports RPI
- Hayes AutoSync (option)
- Fax modem send and receive rates up to 14400 bps
  - V.17, V.29, V.27 ter, and V.21 channel 2
- Voice mode (option)
  - Enhanced ADPCM compression/decompression
  - Tone detection/generation and call discrimination
  - Concurrent DTMF detection
- Business audio mode (with parallel bus interface)
  - Record or playback mono data using 8-bit or 16-bit audio data encoding at 11.025 kHz or 7200 Hz
  - Concurrent DTMF/tone detection
- VoiceView alternating voice and data (AVD) (option)
- Rockwell High Speed Interface (RHSI)
- World-class operation (option)
  - Call progress, blacklisting, multiple countries
- AT, fax class 1, and voice/audio commands
- NVRAM directory and stored profiles
- Built-in DTE interfaces (DTE speed to 57.6 kbps)
  - Parallel 16550A UART interface
  - Serial CCITT V.24 (EIA/TIA-232-E)
  - Fax and RPI data buffers
- Automatic format/speed sensing to 57.6 kbps
- Flow control and speed buffering
- Asynchronous data
- Auto dial and auto answer; tone and pulse dialing
- Calling Number Delivery (Caller ID) detect
- Single 68-pin PLCC package
- +5V operation
- Typical power consumption: 850 mW

**Table 1. Modem Models and Functions**

Model	ECC	Supported Functions						External Memory Required	
		Fax	MNP 10	Voice/ Business Audio	VoiceView	W-Class	Country Support	32k-Byte RAM	ROM
RC144ACFD-x	Modem	-	S	-	-	-	US/Canada	Y	N
RC144ACF(/A)-x	Modem	S	S	-	-	-	US/Canada	Y	N
RCV144ACF(/A)-x	Modem	S	S	S	S	-	US/Canada	Y	N
RC144ACFWD-x	Modem	-	S	-	-	S	Multiple	Y	128k-byte
RC144ACFW-x	Modem	S	S	-	-	S	Multiple	Y	128k-byte
RCV144ACFW-x	Modem	S	S	S	S	S	Multiple	Y	128k-byte
RC144ACFWD-x	Modem	-	S	-	-	S	Single	Y	8k-byte
RC144ACFW-x	Modem	S	S	-	-	S	Single	Y	8k-byte
RCV144ACFW-x	Modem	S	S	S	S	S	Single	Y	8k-byte
RC144ATFD-x	Host	-	-	-	-	-	US/Canada	N	N
RC144ATF-x	Host	S	-	-	-	-	US/Canada	N	N
RCV144ATF-x	Host	S	-	S	-	-	US/Canada	N	N
RC144ATFWD-x	Host	-	-	-	-	S	Multiple	N	128k-byte
RC144ATFW-x	Host	S	-	-	-	S	Multiple	N	128k-byte
RCV144ATFW-x	Host	S	-	S	-	S	Multiple	N	128k-byte
RC144ATFWD-x	Host	-	-	-	-	S	Single	N	8k-byte
RC144ATFW-x	Host	S	-	-	-	S	Single	N	8k-byte
RCV144ATFW-x	Host	S	-	S	-	S	Single	N	8k-byte

**Notes:**

1. ECC

Host                   ECC performed by host CPU and commercially available windows software.  
 Modem                ECC performed by the modem MCU hardware and firmware.

2. Model options:

x                        Host/DTE interface (P = Parallel host; S = Serial DTE)  
 (/A)                   Optional Hayes AutoSync.  
 D                       Data only (no fax).  
 V                       Voice (including business audio for parallel interface)  
 W                       World class support.

3. Supported functions (S = Supported; - = Not supported):

Fax                     Fax class 1 command functions.  
 Voice                  Voice and business audio command functions.  
 VoiceView            VoiceView alternating voice and data (AVD)  
 W-Class               World class functions supporting multiple country requirements.

RPI+ and ConfigurACE are trademarks of Rockwell International.  
 MNP is a trademark of Microcom, Inc.  
 VoiceView is a registered trademark of Radish Communications, Inc.  
 Hayes is a trademark of Hayes Microcomputer Products, Inc.

## TECHNICAL SPECIFICATIONS

### GENERAL DESCRIPTION

The single device modem provides the processing core for a complete modem design. The OEM adds a crystal, discrete components, and a digital access arrangement (DAA) circuit to complete the modem system.

The modem is the full-featured, self-contained data/fax/voice/business audio solution shown in Figure 1. No external microcontroller for data or fax control functions is required. Dialing, call progress, and telephone line interface functions are fully supported and controlled through the AT command set.

The modem connects to the DTE via a V.24 (EIA/TIA-232-E) serial interface or to a host via a parallel microcomputer bus depending on modem model.

#### Data Modem

As a data modem, the modem can operate in 2-wire, full-duplex, asynchronous modes at line rates up to 14400 bps. Data modes perform complete handshake and data rate negotiations. All tone and pattern detection required by the applicable CCITT or Bell standard are supported.

#### Fax Modem

As a fax modem, the MDP fully supports Group 3 facsimile send and receive speeds of 14400, 12000, 9600, 7200, 4800, or 2400 bps. Fax data transmission and reception performed by the modem is controlled and monitored through the fax EIA-578 Class 1 command interface. Full HDLC formatting, zero insertion/deletion, and CRC generation/checking is provided.

Both transmit and receive fax data are buffered within the modem. Data transfer to and from the DTE is flow controlled by XON/XOFF.

#### Modem Firmware

Modem firmware in internal ROM performs processing of general modem control and command sets. Separate modem models support parallel host interface or serial DTE interface operation.

### SUPPORTED INTERFACES

The major hardware signal interfaces of the modem device set are illustrated in Figure 1.

#### Parallel Host Bus Interface

A 16550A UART-compatible parallel interface is provided in the parallel interface version. Eight data lines, three address lines, four control/status lines, and a reset line are supported.

In addition, a 512-byte fax data buffer and a 256-byte RPI data buffer are used to provide reliable performance in a multi-tasking environment.

#### DTE Serial/Indicator Interface

A V.24/EIA/TIA-232-E logic-compatible DTE serial interface is provided in the serial interface version. One serial data input and one serial data output are supported. Two control inputs and five status outputs are supported.

#### NVRAM Interface

A serial interface to an optional OEM-supplied non-volatile RAM (NVRAM) is provided. Data stored in NVRAM can take precedence over the factory default settings. A 256-byte NVRAM can store up to two user-selectable configurations and can store up to four 35-digit dial strings.

#### Speaker Interface

A speaker output, controlled by AT commands, is provided for an optional OEM-supplied speaker circuit.

#### External Bus Interface

The external bus is not used in ATF models.

For ACF and ACFW models, the external bus connects to OEM-supplied 32k-byte, 70 ns RAM. For ACFW and ATF models, the external bus also connects to OEM-supplied 8k-byte (single country support) or 128k-byte (multiple country support), 70 ns ROM. This non-multiplexed bus supports eight bidirectional data lines and 17 address output lines. Read enable, write enable, and ROM and RAM chip select outputs are also supported.

#### Telephone Line Interface

A receive analog input, two transmit analog outputs, five relay driver outputs, and a ring signal input are supported. The relay outputs may be used to control relays such as off-hook, pulse, Caller ID, voice, .mute, A/A1, earth, and talk/data relays. A line current sense input is also supported.

#### Microsoft Windows Interfac

**Rockwell High Speed Interface (RHSI).** Business audio operation features data rates in excess of 115.2 kbps and requires higher DTE/DCE throughput than can be supported by the standard communications driver supplied with Microsoft Windows. The Rockwell High Speed Interface (RHSI) host software is provided to overcome these predefined communication port speed limitations and enables business audio operation. The Rockwell RHSICOMM.DRV driver replaces and is downward compatible with the standard Microsoft Windows communications driver COMM.DRV.

**Enhanced Rockwell Protocol Interface (RPI+) and WinRPI Host Software Module.** The RC144ATF modem incorporates the enhanced Rockwell Protocol Interface (RPI+) and provides error correction and data compression (ECC) in conjunction with a provided host software module (WinRPI).

WinRPI allows implementation of high performance PC-based error correction and data compression with full compatibility to existing Windows-based communications applications.

The RC144ATF with RPI+ is also backwards compatible to applications software currently shipping with Rockwell's host-based ECC module based upon the original version of the Rockwell Protocol Interface (RPI).

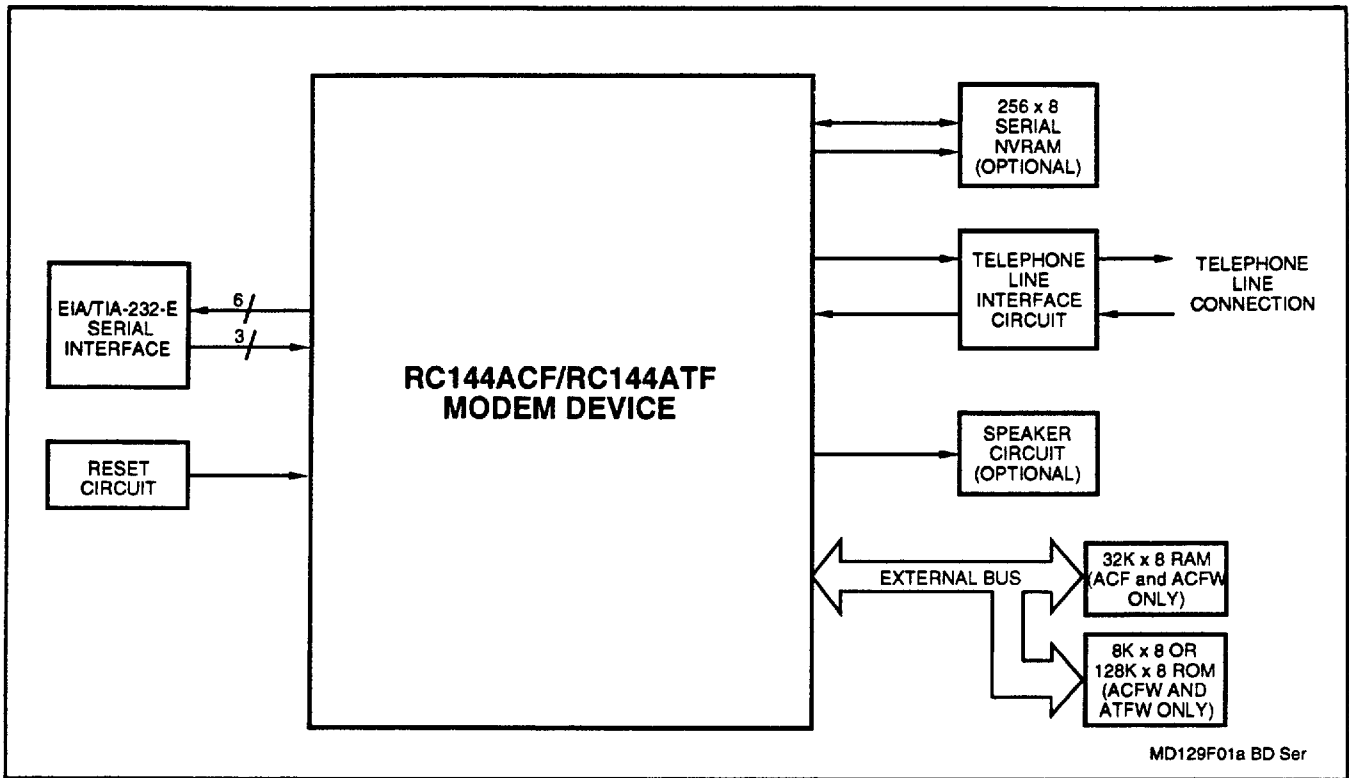

Figure 1a. Block Diagram - Serial Interface

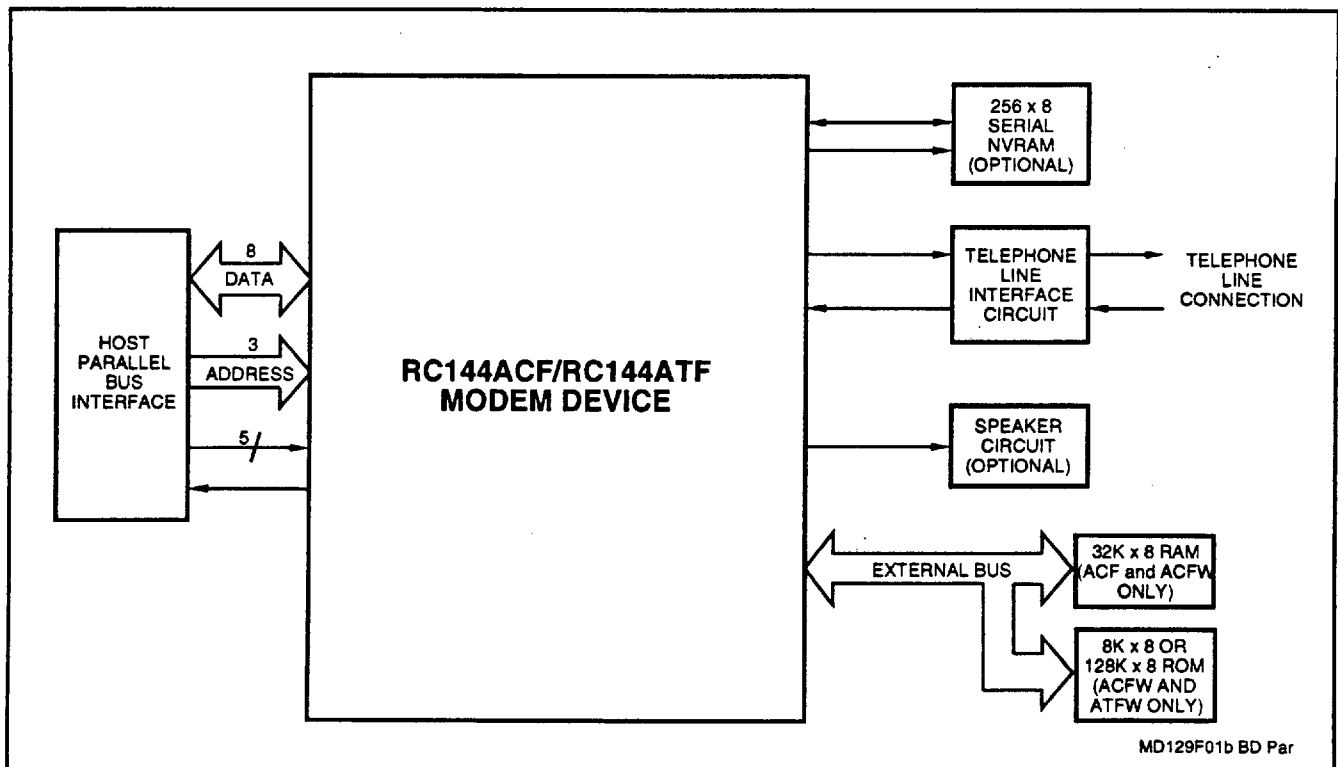

Figure 1b. Block Diagram - Parallel Interface

**COMMANDS**

The modem supports data modem, fax class 1 modem, voice/audio, and VoiceView commands, and S Registers in accordance with modem model options (see Tables 2 and 3, respectively).

**Data Modem Operation.** Data modem functions operate in response to the AT commands when +FCLASS=0. Default parameters support US/Canada operation.

**MNP 10 Operation.** MNP 10 functions operate in response to MNP 10 commands.

**AutoSync Operation.** AutoSync operates in response to the &Q4 command.

**Fax Modem Operation.** Fax modem functions operate in response to fax class 1 commands when +FCLASS=1 or #CLS=1.

**Voice Operation.** Voice mode functions operate in response to voice/audio commands when #CLS=8 and either #VBS=2 or #VBS=4 is selected.

**Audio Operation.** Audio mode functions operate in response to voice/audio commands when #CLS=8 and either #VBS=8 or #VBS=16 is selected.

**World Class (W-Class) Operation.** Models supporting W-class functions operate in response to W-class AT commands.

**VoiceView Operation.** VoiceView alternating voice and data functions operate in response to VoiceView commands.

**Table 2. AT Commands**

Command	Function	ACF/ACFD/ ACFW/ACFWD	ATF/ATFD/ ATFW/ATFWD
<b>Basic Commands</b>			
A/	Re-execute command	X	X
A	Answer a call	X	X
Bn	Set CCITT or Bell Mode	X	X
Cn	Carrier control	X	X
Dn	Dial (originate a call)	X	X
E	Command echo	X	X
Fn	Select line modulation	X	X
Hn	Disconnect (hang-up)	X	X
In	Identification	X	X
Ln	Speaker volume	X	X
Mn	Speaker control	X	X
Nn	Automode enable	X	X
On	Return to on-line data mode	X	X
P	Set pulse dial default	X	X
Qn	Quiet results codes control	X	X
Sn=x	Write to S Register	X	X
Sn?	Read S Register	X	X
T	Set tone dial default	X	X
Vn	Result code form	X	X
Wn	Error correction message control	X	X
Xn	Extended result codes	X	X
Yn	Long space disconnect	X	X
Zn	Soft reset and restore profile	X	X

Table 2 AT Commands (Cont'd)

Command	Function	ACF/ACFD/ ACFW/ACFWD	ATF/ATFD/ ATFW/ATFWD
&Cn	RLSD (DCD) option	X	X
&Dn	DTR option	X	X
&F	Restore factory configuration (profile)	X	X
&Gn	Select guard tone	X	X
&Jn	Telephone jack control	X	X
&Kn	Flow control	X	X
&Mn	Asynchronous/ mode selection	X	X
&Pn	Select pulse dial make/break ratio	X	X
&Qn	Asynchronous mode selection	X	X
&Rn	RTS/CTS option	X	X
&Sn	DSR override	X	X
&Tn	Test and diagnostic	X	X
&V	Display current configuration & profiles	X	X
&Wn	Store current configuration	X	X
&Xn	Select synchronous clock source	X	X
&Yn	Designate a default reset profile	X	X
&Zn=x	Store phone number	X	X
%En	Enable/disable line quality monitor	X	X
%L	Report line signal level	X	X
%Q	Report line signal quality	X	X
%TTn	PTT testing utilities	X	X
\Kn	Break control	X	X
\Nn	Operating mode	X	X
#CID	Caller ID detection and reporting	X	X
+Hn	Enable/disable RPI and DTE speed	X	X
**	Download to flash memory	X	X
T	EC <sup>2</sup> Commands		
%C	Select data compression	X	X
\An	Maximum MNP block size	X	-
\Bn	Transmit BREAK to remote	X	-
	MNP 10 Commands		
)Mn	Enable/disable cellular power level adjust	X	-
*Hn	Set link negotiation speed	X	-
-Kn	MNP extended services	X	-
-Qn	Enable fallback to V.22 bis/V.22	X	-
@Mn	Select initial transmit level	X	-
:E	Compromise equalizer enable	X	-
	W-Class Commands		
*B	Display blacklisted numbers	W only	W only
*D	Display delayed numbers	W only	W only
*NCnn	Country select	W only	W only

Table 2. AT Commands (Cont'd)

Command	Function	ACF/ACFD/ ACFW/ACFWD	ATF/ATFD/ ATFW/ATFWD
<b>Fax Class 1 Commands</b>			
+FCLASS=n	Service class	X (except D)	X (except D)
+FAE	Data/fax auto answer	X (except D)	X (except D)
+FTS=n	Stop transmission and wait	X (except D)	X (except D)
+FRS=n	Receive silence	X (except D)	X (except D)
+FTM=n	Transmit data	X (except D)	X (except D)
+FRM=n	Receive data	X (except D)	X (except D)
+FTH=n	Transmit data with HDLC framing	X (except D)	X (except D)
+FRH=n	Receive data with HDLC framing	X (except D)	X (except D)
<b>Voice Commands</b>			
#BDR	Select baud rate	V only	V only
#CLS	Select data, fax, or voice	V only	V only
#MDL?	Identify model	V only	V only
#MFR?	Identify manufacturer	V only	V only
#REV?	Identify revision level	V only	V only
#VBQ?	Query buffer size	V only	V only
#VBS	Bits per sample	V only	V only
#VBT	Beep tone timer	V only	V only
#VCI?	Identify compression method	V only	V only
#VLS	Voice line select	V only	V only
#VRA	Ringback goes away timer (originate)	V only	V only
#VRN	Ringback never came timer (originate)	V only	V only
#VRX	Voice receive mode	V only	V only
#VSD	Enable silence deletion	V only	V only
#VSK	Buffer skid setting	V only	V only
#VSP	Silence detection period (voice receive)	V only	V only
#VSR	Sampling rate selection	V only	V only
#VSS	Silence detection tuner (voice receive)	V only	V only
#VTD	DTMF/tone reporting	V only	V only
#VTS	Generate tone signals	V only	V only
#VTX	Voice transmit mode	V only	V only
<b>VoiceView Commands</b>			
+FCLASS=n	Service class	V only	-
-SVV	Originate VoiceView data mode	V only	-
-SAC	Accept data mode request	V only	-
-SIP	Initialize VoiceView parameters	V only	-
-SIC	Reset capabilities data to default setting	V only	-
-SSQ	Initiate capabilities query	V only	-
-SDA	Originate modem data mode	V only	-
-SFX	Originate FAX data mode	V only	-
-SMT	Mute telephone	V only	-
-SDS	Disable switchhook status monitoring	V only	-
-SQR	Capabilities query response control	V only	-
-SCD	Capabilities data	V only	-
-SER?	Error status (read only)	V only	-
-SSP	VoiceView transmission speed	V only	-
-SSR	Start sequence response control	V only	-
+FLO	Flow control select	V only	-
+FPR	Serial port rate control	V only	-
-SSV	VoiceView data mode start sequence event	V only	-
-SFA	Facsimile data mode start sequence event	V only	-
-SMD	Modem data mode start sequence event	V only	-
-SRA	Receive ADSI response event	V only	-
-SRQ	Receive capabilities query event	V only	-
-SRC	Receive capabilities information event	V only	-
-STO	Talk-off event	V only	-

Table 3. S Registers

Register	Function	ACF/ACFD/ ACFW/ACFWD	ATF/ATFD/ ATFW/ATFWD
S0	Rings to auto-answer	X	X
S1	Ring counter	X	X
S2	Escape character	X	X
S3	Carriage return character	X	X
S4	Line feed character	X	X
S5	Backspace character	X	X
S6	Maximum time to wait for dial tone	X	X
S7	Wait for carrier	X	X
S8	Pause time for dial delay modifier	X	X
S9	Carrier detect response time	X	X
S10	Carrier loss disconnect time	X	X
S11	DTMF tone duration	X	X
S12	Escape code guard time	X	X
S13	Reserved	X	X
S14	General bit mapped options	X	X
S15	Reserved	X	X
S16	Test mode bit mapped options (&T)	X	X
S17	Reserved	X	X
S18	Test timer	X	X
S19	AutoSync Bit Mapped Options	/A or W Only	/A or W Only
S20	AutoSync HDLC Addr or BSC Sync Char	/A or W Only	/A or W Only
S21	V24/general bit mapped options	X	X
S22	Speaker/results bit mapped options	X	X
S23	General bit mapped options	X	X
S24	Reserved	-	-
S25	Delay to DTR (CT108) off	X	X
S26	RTS-to-CTS (CT105-to-CT106) delay	X	X
S27	General bit mapped options	X	X
S28	General bit-mapped options	X	X
S29	Flash modifier time	X	X
S30	Inactivity timer	X	X
S31	General bit-mapped options	X	X
S32	XON character	X	X
S33	XOFF character	X	X
S34-S35	Reserved	X	X
S37	Line connection speed	X	X
S38	Delay before forced hangup	X	X
S39	Flow control	X	X
S40	General bit-mapped options	X	X
S41	General bit-mapped options	X	X
S42-S45	Reserved	X	X
S91	PSTN transmit attenuation level	X	X
S92	Fax transmit attenuation level	X	X
S95	Result code messages control	X	X
	<b>ECC S Registers</b>		
S36	LAPM failure control	X	X
S46	Data compression control	X	X
S48	V.42 negotiation control	X	X
S82	Break handling control	X	-
S86	Call failure reason code	X	-
	<b>Cellular Registers</b>		
S201	Cellular transmit level	X	-

**DTE SERIAL INTERFACE OPERATION**

**Command Mode and Data Modem Mode - Automatic Speed/Format Sensing.** The modem can automatically determine the speed and format of the data sent from the DTE. The modem can sense speeds of 300, 600, 1200, 2400, 4800, 7200, 9600, 12000, 14400, 19200, 38400, and 57600 bps and the following data formats:

Parity	Data Length (No. of Bits)	No. of Stop Bits	Character Length (No. of Bits)
None	7	2	10
Odd	7	1	10
Even	7	1	10
None	8	1	10
Odd	8	1	11*
Even	8	1	11*

\* 11-bit characters are sensed, but the parity bits are stripped off during data transmission in Normal and Error Correction modes. Direct mode does not strip off the parity bits.

The modem can speed sense data with mark or space parity and configures itself as follows:

DTE Configuration	Modem Configuration
7 mark	7 none
7 space	8 none
8 mark	8 none
8 space	8 even

**Fax Modem Mode.** The DTE to modem data rate is 19200 bps.

**HOST PARALLEL BUS INTERFACE OPERATION**

**Command Mode and Data Modem Mode.** The modem can operate at rates up to 57600 bps by programming the Divisor Latch in the parallel interface registers.

**Fax Modem Mode.** The host to modem data rate is 19200 bps.

**ESTABLISHING DATA MODEM CONNECTIONS**

**Telephone Number Directory**

The modem supports four telephone number entries in a directory that can be saved in a serial NVRAM. Each telephone number can be up to 35 characters in length. A telephone number can be saved using the &Zn=x command, and a saved telephone number can be dialed using the DS=n command.

**Dialing**

**DTMF Dialing.** DTMF dialing using DTMF tone pairs is supported in accordance with CCITT Q.23. The transmit tone level complies with Bell Publication 47001.

**Pulse Dialing.** Pulse dialing is supported in accordance with EIA/TIA-496-A.

**Blind Dialing.** The modem can blind dial in the absence of a dial tone if enabled by the X0, X1, or X3 command.

**Modem Handshaking Protocol**

If a tone is not detected within the time specified in the S7 register after the last digit is dialed, the modem aborts the call attempt.

**Call Progress Tone Detection**

Ringback, equipment busy, and progress tones can be detected in accordance with the applicable standard.

**Answer Tone Detection**

Answer tone can be detected over the frequency range of 2100 ± 40 Hz in CCITT modes and 2225 ± 40 Hz in Bell modes.

**Ring Detection**

A ring signal can be detected from a TTL-compatible 15.3 Hz to 68 Hz square wave input.

**Billing Protection**

When the modem goes off-hook to answer an incoming call, both transmission and reception of data are prevented for 2 seconds (data modem) or 4 seconds (fax adaptive answer) to allow transmission of the billing signal.

**Connection Speeds**

The possible data connection modes/speeds are in Table 4.

Two methods of establishing a connection are supported: use of the F command and use of N command, speed sense, and S37 register combination.

**Table 4. Connection Speed Options**

Configuration	Rate (bps)
V.32 bis	14400 (RC144ACL/ATF), 12000 (RC144ACF/ATF), 9600, 7200, or 4800
V.32	9600 or 4800
V.22 bis	2400 or 1200
V.22	1200
V.23	1200Tx/75Rx or 75TX/1200Rx
V.21	0-300
Bell 212A	1200
Bell 103	0-300

**Automode**

Automode detection can be enabled by the N1 or F0 commands to allow the modem to connect to a remote modem in accordance with EIA/TIA-PN2330.

**DATA MODE**

Data mode exists when a telephone line connection has been established between modems and all handshaking has been completed.

**Speed Buffering (Normal Mode)**

Speed buffering allows a DTE to send data to, and receive data from, a modem at a speed different than the line speed. The modem supports speed buffering at all line speeds.

**Flow Control**

**DTE-to-Modem Flow Control.** If the modem-to-line speed is less than the DTE-to-modem speed, the modem supports XOFF/XON or RTS/CTS flow control with the DTE to ensure data integrity.

### Escape Sequence Detection

The "+++  
escape sequence can be used to return control to the command mode from the data mode. Escape sequence detection is disabled by an S2 Register value greater than 127. Escape sequence detection is disabled in synchronous mode.

### BREAK Detection

The modem can detect a BREAK signal from either the DTE or the remote modem. The \Kn command determines the modem response to a received BREAK signal.

### Telephone Line Monitoring

**GSTN Cleardown (V.32 bis, V.32).** Upon receiving GSTN Cleardown from the remote modem in a non-error correcting mode, the modem cleanly terminates the call.

**Loss of Carrier.** If carrier is lost for a time greater than specified by the S10 register, the modem disconnects.

**Receive Space Disconnect.** If selected by the Y1 command in non-error-correction mode, the modem disconnects after receiving  $1.6 \pm 10\%$  seconds of continuous SPACE.

### Send SPACE on Disconnect

If selected by the Y1 command in non-error-correction mode, the modem sends  $4 \pm 10\%$  seconds of continuous SPACE when a locally commanded hang-up is issued by the &Dn or H command.

### Fall Forward/Fallback (V.32 bis/V.32)

During initial handshake, the modem will fallback to the optimal line connection within V.32 bis/V.32 mode depending upon signal quality if automode is enabled by the N1 command.

When connected in V.32 bis/V.32 mode, the modem will fall forward or fallback to the optimal line speed within V.32 bis/V.32 mode depending upon signal quality if fall forward/fallback is enabled by the %E2 command.

### Retrain

The modem may lose synchronization with the received line signal under poor line conditions. If this occurs, retraining may be initiated to attempt recovery depending on the type of connection.

The modem initiates a retrain if line quality becomes unacceptable if enabled by the %E command. The modem continues to retrain until an acceptable connection is achieved, or until 30 seconds elapse resulting in line disconnect.

### Programmable Inactivity Timer

The modem disconnects from the line if data is not sent or received for a specified length of time. In normal or error-correction mode, this inactivity timer is reset when data is received from either the DTE or from the line. This timer can be set to a value between 0 and 2550 seconds by using register S30. A value of 0 disables the inactivity timer.

### Direct Mode (Serial Interface Only)

The Direct mode allows data to be transmitted and received directly from the DTE and remote modem. The Direct mode is selected with the &Q0 or \N1 command. In Direct mode, no flow control characters are recognized or transmitted, the modem cannot execute error correction, and the inactivity timer is not used.

### DTE Signal Monitoring (Serial Interface Only)

**-DTR.** When -DTR is asserted, the modem responds in accordance with the &Dn and &Qn commands.

**-RTS.** -RTS is used for flow control if enabled by the &K command in normal or error-correction mode.

## ERROR CORRECTION AND DATA COMPRESSION (RC144ACF MODELS ONLY)

### V.42 Error Correction

V.42 supports two methods of error correction: LAPM and, as a fallback, MNP 4. The modem provides a detection and negotiation technique for determining and establishing the best method of error correction between two modems.

### MNP 2-4 Error Correction

MNP 2-4 is a data link protocol that uses error correction algorithms to ensure data integrity. Supporting stream mode, the modem sends data frames in varying lengths depending on the amount of time between characters coming from the DTE.

### V.42 bis Data Compression

V.42 bis data compression mode, enabled by the %Cn command or S46 register, operates when a LAPM or MNP 10 connection is established.

The V.42 bis data compression employs a "string learning" algorithm in which a string of characters from the DTE is encoded as a fixed length codeword. Two 2k-byte dictionaries are used to store the strings. These dictionaries are dynamically updated during normal operation.

### MNP 5 Data Compression

MNP 5 data compression mode, enabled by the %Cn command, operates during an MNP connection.

In MNP 5, the modem increases its throughput by compressing data into tokens before transmitting it to the remote modem, and by decompressing encoded received data before sending it to the DTE.

## MNP 10 DATA THROUGHPUT ENHANCEMENT (ACF AND ACFW ONLY)

MNP 10 protocol, cellular functionality, and MNP Extended Services enhance performance under adverse channel conditions such as those found in rural, long distance, or cellular environments. An MNP 10 connection is established when an MNP 2-4 connection is negotiated with a remote modem supporting MNP 10. MNP 10 functions include:

**Robust Auto-Reliability.** A higher connection success rate is achieved by attempting to overcome channel interference during the modem negotiation phase while maintaining backward compatibility with non-MNP 10 modems.

**Negotiated Speed Upshift.** Initial connection and MNP handshake is performed at the most dependable speed, then the connection upshifts to the highest supported modem/channel speed. This function is particularly useful for channel conditions with high connection failure rates.

**Aggressive Adaptive Packet Assembly.** Frame size is dynamically changed to quickly adapt to varying levels of interference.

**Dynamic Speed Shifting.** Connection speed is shifted upward or downward to optimize data throughput for the channel conditions by continuously monitoring the line quality and link performance.

**Dynamic Transmit Level Adjustment (DTLA).** When enabled by the )M1 command, transmit level is dynamically adjusted to adapt to the varying cellular network environment, and to prevent "clipping" which causes data corruption due to the Preemphasis and Compander effect.

**MNP Extended Services.** The modem can revert from V.42 bis/LAPM operation to MNP operation when MNP extended services is enabled by the local and remote modems.

## AUTOSYNC

Hayes AutoSync mode, when used with communications software incorporating the Hayes Synchronous Interface (HSI), provides synchronous communication capabilities from an asynchronous data terminal. In AutoSync, the modem places the call asynchronously then automatically switches to synchronous operation once the telephone connection has been established. AutoSync allows communication from an asynchronous DTE (typically a personal computer) to synchronous DTE (typically a mainframe computer or minicomputer).

## FAX CLASS 1 OPERATION

The modem operates as a facsimile (fax) DCE whenever the +FCLASS=1 command is active. In the fax mode, the on-line behavior of the modem is different from the data (non-fax) mode. After dialing, modem operation is controlled by fax commands. Some AT commands are still valid but may operate differently than in data modem mode.

Calling tone is generated in accordance with T.30.

## VOICE/AUDIO MODE

Voice and audio functions are supported by the Voice Mode. Voice Mode includes three submodes: Online Voice Command Mode, Voice Receive Mode, and Voice Transmit Mode (Table 2).

**Online Voice Command Mode.** This mode results from the connection to the telephone line or a voice/audio I/O device (e.g., microphone, speaker, or handset) through the use of the #CLS=8 and #VLS commands. After mode entry, AT commands can be entered without aborting the connection.

**Voice Receive Mode.** This mode is entered when the #VRX command is active in order to record voice or audio data input at the RXA pin, typically from a microphone/handset or the telephone line.

Received analog voice samples are converted to digital form and compressed for reading by the host. AT commands control the codec bits-per-sample rate and, optionally, select silence deletion including silence detection period adjustment.

Received analog mono audio samples are converted to digital form and formatted into 8-bit unsigned linear PCM or 16-bit signed linear PCM format for reading by the host. AT commands control the bit length and sampling rate. Concurrent DTMF/tone detection is available at the 7200 Hz sample rate.

**Voice Transmit Mode.** This mode is entered when the #VTX command is active in order to playback voice or audio data to the TXA1/TXA2 output pins, typically to a speaker/handset or to the telephone line.

Digitized voice data is decompressed and converted to analog form at the original compression quantization sample-per-bits rate then output to the TXA1/TXA2 pins. Optional silence interpolation is enabled if silence deletion was selected for voice compression.

Digitized audio data is converted to analog form then output to the TXA1/TXA2 pins.

## VOICEVIEW

Voice and data can alternately sent and received in a time-multiplexed fashion over the telephone line whenever the +FCLASS=80 command is active. This command and other VoiceView commands embedded in host communications software control modem operation. Most VoiceView commands use an extended syntax starting with the characters "-S", which signifies the capability to switch between voice and data.

## CALLER ID

Caller ID can be enabled/disabled using the #CID command. When enabled, caller ID information (date, time, caller code, and name) can be passed to the DTE in formatted or unformatted form. Inquiry support allows the current caller ID mode and mode capabilities of the modem to be retrieved from the modem.

## WORLD CLASS COUNTRY SUPPORT (RC144ATFW AND RC144ACFW MODELS ONLY)

The W-class models include functions which support modem operation in multiple countries. The following capabilities are provided in addition the data modem functions previously described. Country dependent parameters are all programmable by ConfigurACE.

### Dialing

**Dial Tone Detection.** Dial tone detection levels and frequency ranges are programmable by ConfigurACE.

**DTMF Dialing.** Transmit output level, DTMF signal duration, and DTMF interdigit interval parameters are programmable by ConfigurACE.

**Pulse Dialing.** Parameters such as make/break times, set/clear times, and dial codes are programmable by ConfigurACE.

**Ring Detection.** The frequency range is programmable by ConfigurACE.

**Blind Dialing.** Blind dialing may be disabled by ConfigurACE.

### Carrier Transmit Level

The carrier transmit level can be programmed through S91 for data and S92 for fax. The maximum, minimum, and default values can be defined by ConfigurACE to match specific country and DAA requirements.

### Calling Tone

Calling tone is generated in accordance with V.25. Calling tone may be toggled (enabled/disabled) by inclusion of a "A" character in a dial string. It may also be disabled by programming a country specific parameter using ConfigurACE.

### Call Progress Tone Detection

Frequency and cadence of tones for busy, ringback, congested, dial tone 1, and dial tone 2 are programmable by ConfigurACE.

### Answer Tone Detection

The answer tone detection period is programmable by ConfigurACE.

### Blacklist Parameters

The modem can operate in accordance with requirements of individual countries to prevent misuse of the network by limiting repeated calls to the same number when previous call attempts have failed. Call failure can be detected for reasons such as no dial tone, number busy, no answer, no ringback detected, voice (rather than modem) detected, and key abort (dial attempt aborted by user). Actions resulting from such failures can include specification of minimum inter-call delay, extended delay between calls, and maximum numbers of retries before the number is permanently forbidden ("blacklisted"). Up to six such numbers may be tabulated. The blacklist parameters are established by ConfigurACE.

### Relay Control

On-hook/off-hook, make/break, and set/clear relay control parameters are programmable by ConfigurACE.

## DIAGNOSTICS

### Commanded Tests

Diagnostics are performed in response to &T commands.

**Analog Loopback (&T1 Command).** Data from the local DTE is sent to the modem, which loops the data back to the local DTE.

**Analog Loopback with Self Test (&T8 Command).** An internally generated test pattern of alternating 1s and 0s (reversals) is sent to the modem. An error detector within the modem checks for errors in the string of reversals.

**Remote Digital Loopback (RDL) (&T6 Command).** Data from the local DTE is sent to the remote modem which loops the data back to the local DTE.

**Remote Digital Loopback with Self Test (&T7 Command).** An internally generated pattern is sent from the local modem to the remote modem, which loops the data back to the local modem.

**Local Digital Loopback (&T3 Command).** When local digital loop is requested by the local DTE, two data paths are set up in the local modem. Data from the local DTE is looped back to the local DTE (path 1) and data received from the remote modem is looped back to the remote modem (path 2).

### Power On Reset Tests

Upon power on or receipt of the Z command, the modem performs tests of modem functions.

If a test fails, the DCD bit in the parallel interface register is pulsed (parallel interface version) as follows:

RAM test fails: One pulse every two seconds.

ROM test fails: Two pulses every two seconds.

Other: Three pulses every two seconds.

If the NVRAM test fails (due to NVRAM failure or if NVRAM is not installed), the test failure is reported by AT commands that normally use the NVRAM, e.g., the &V command.

### **CONFIGURACE UTILITY PROGRAM**

The PC-based ConfigurACE utility program allows the OEM to customize the modem firmware for external ROM to suit specific application and country requirements. ConfigurACE allows programming of functions such as:

- Loading of multiple sets of country parameters
- Loading of NVRAM factory profiles
- Call progress and blacklisting parameters
- Entry of S register maximum/minimum values
- Limitation of transmit levels
- Modification of result codes
- Modification of factory default values
- Customization of the AT14 response
- Customization of fax OEM messages

This program modifies the hex object code which can be programmed directly into the system EPROM. Lists of the generated parameters can be displayed or printed.

Rockwell-provided country parameter files allow a complete set of country-specific call progress and blacklisting parameters to be selected.

### **ADDITIONAL INFORMATION**

Additional information is described in the RC144ACF and RC144ATF Designer's Guide (Order No. 1055) and in the AT Command Reference Manual (Order No. 883).

### **HARDWARE INTERFACES**

The modem hardware interface signals for the DTE serial interface is shown in Figure 2.

The modem hardware interface signals for the host parallel interface is shown in Figure 3.

The pin assignments for DTE serial interface operation are shown in Figure 4 are listed in Table 5.

The pin assignments for host parallel interface operation are shown in Figure 5 are listed in Table 6.

The hardware interface signals are defined in Table 7.

The digital electrical characteristics for the hardware interface signals are listed in Table 8.

The analog electrical characteristics for the hardware interface signals are listed in Table 9.

The current and power requirements are listed in Table 10.

The absolute maximum ratings are listed in Table 11.

Table 12 shows the parallel interface registers and the corresponding bit assignments.

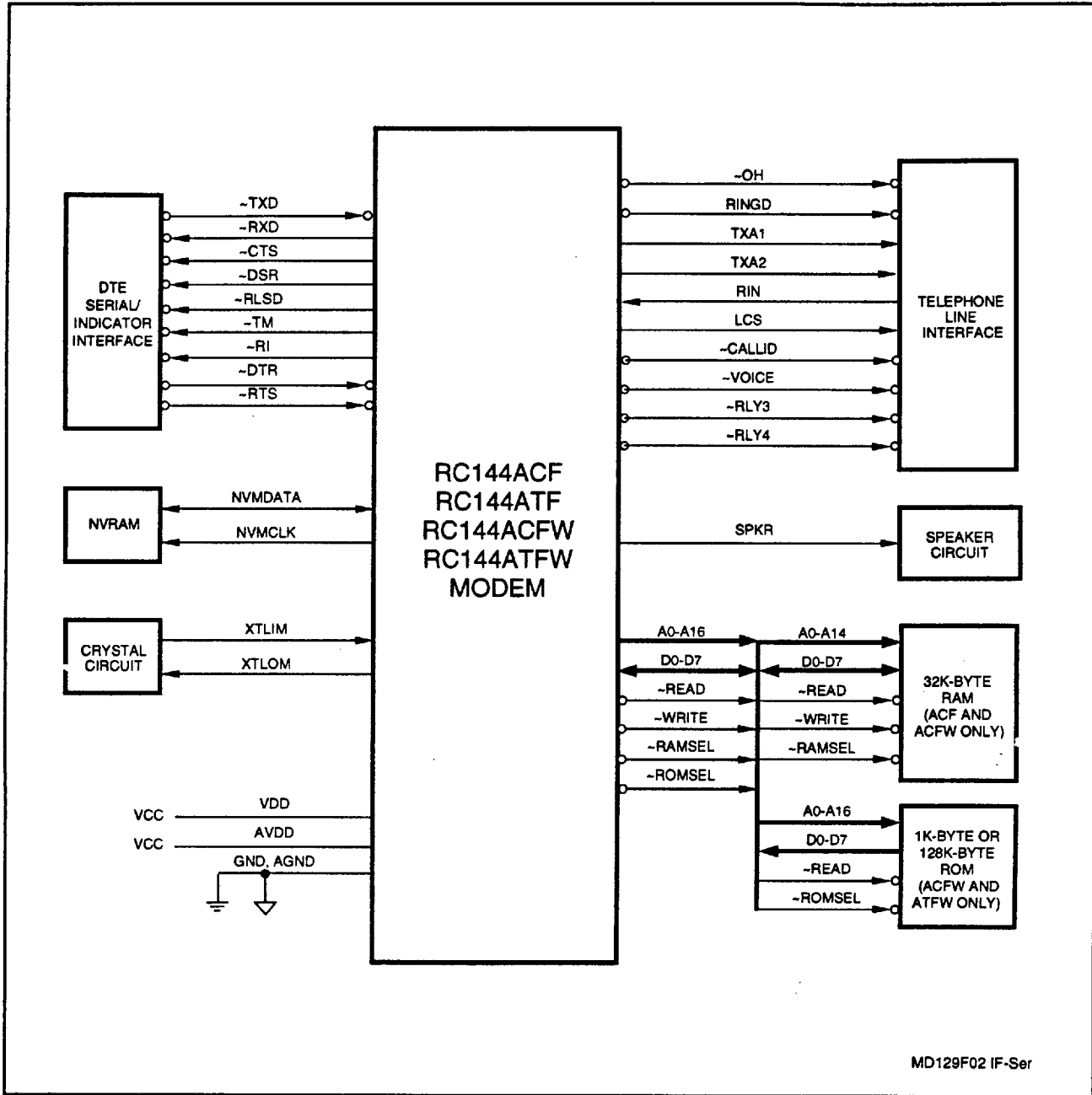

Figure 2. Hardware Interface Signals - Serial Interface

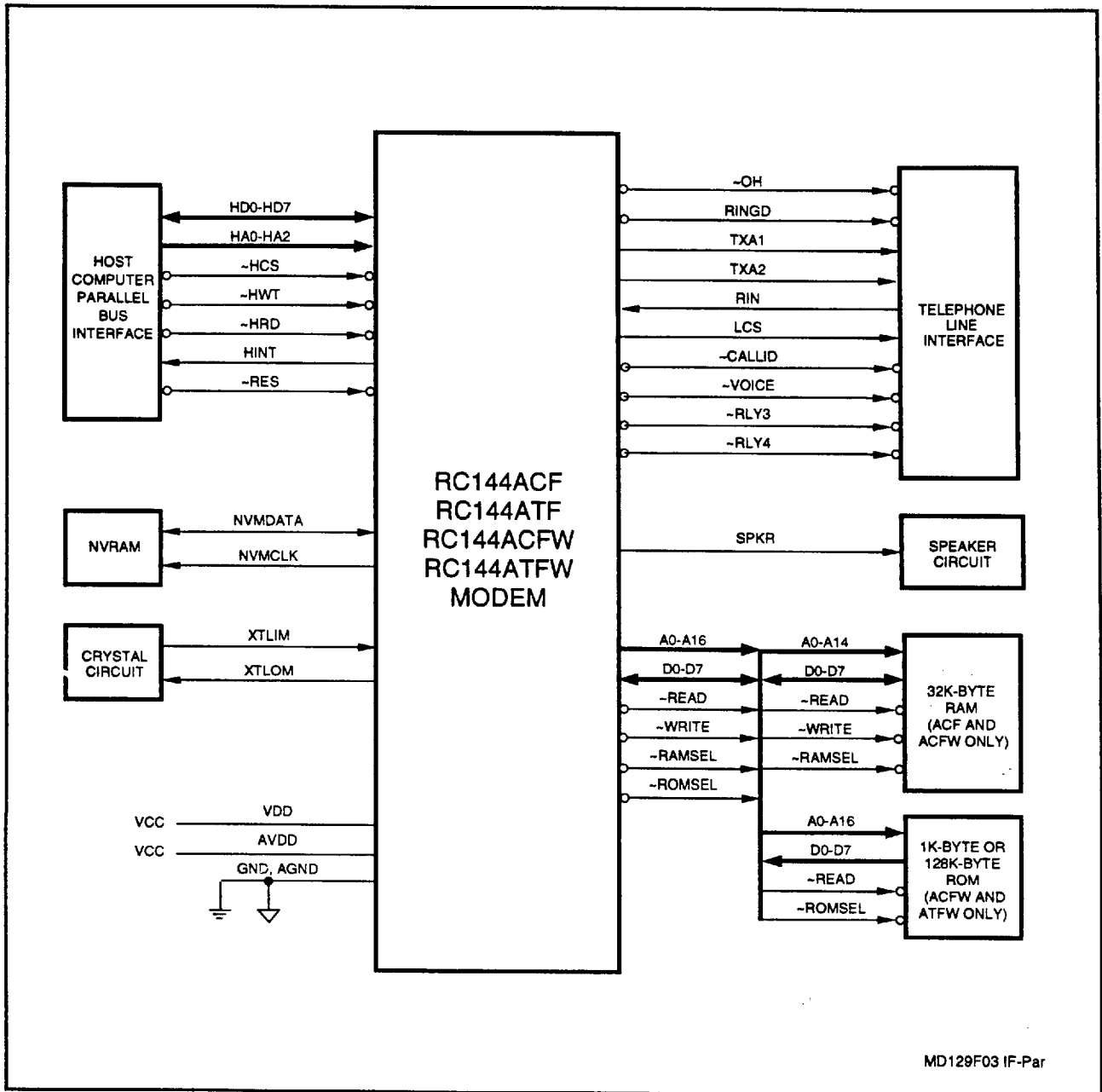

Figure 3. Hardware Interface Signals - Parallel Interface

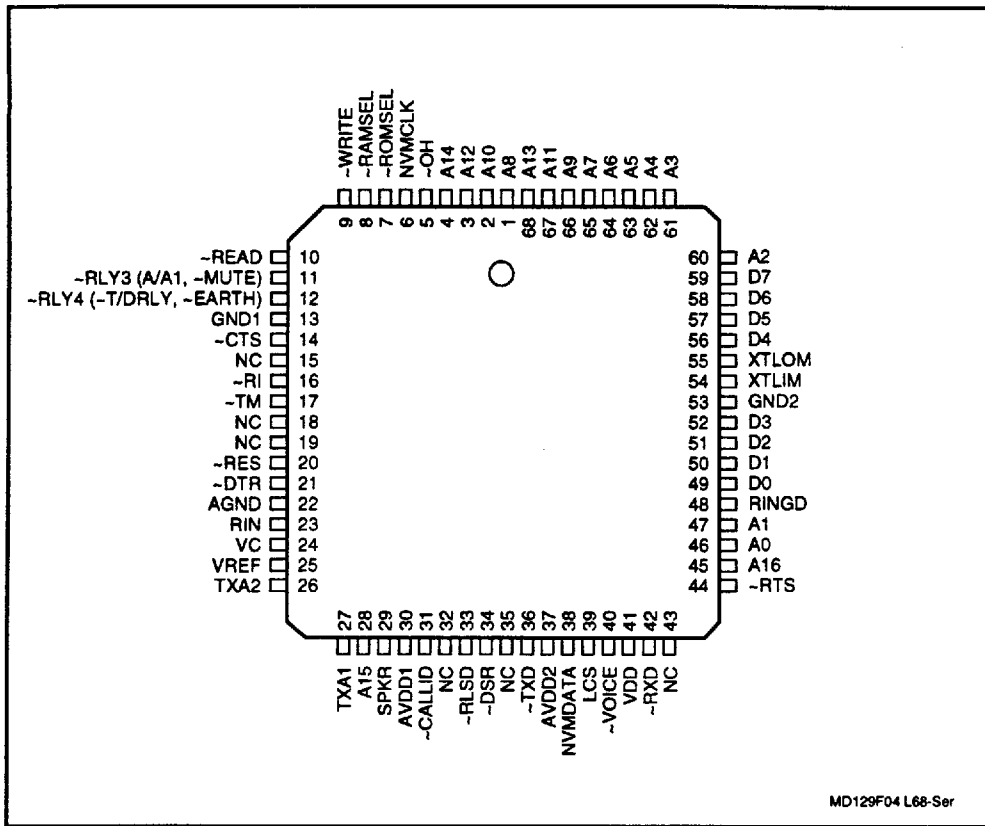

Figure 4. Pin Signals - 68-Pin PLCC - Serial Interface

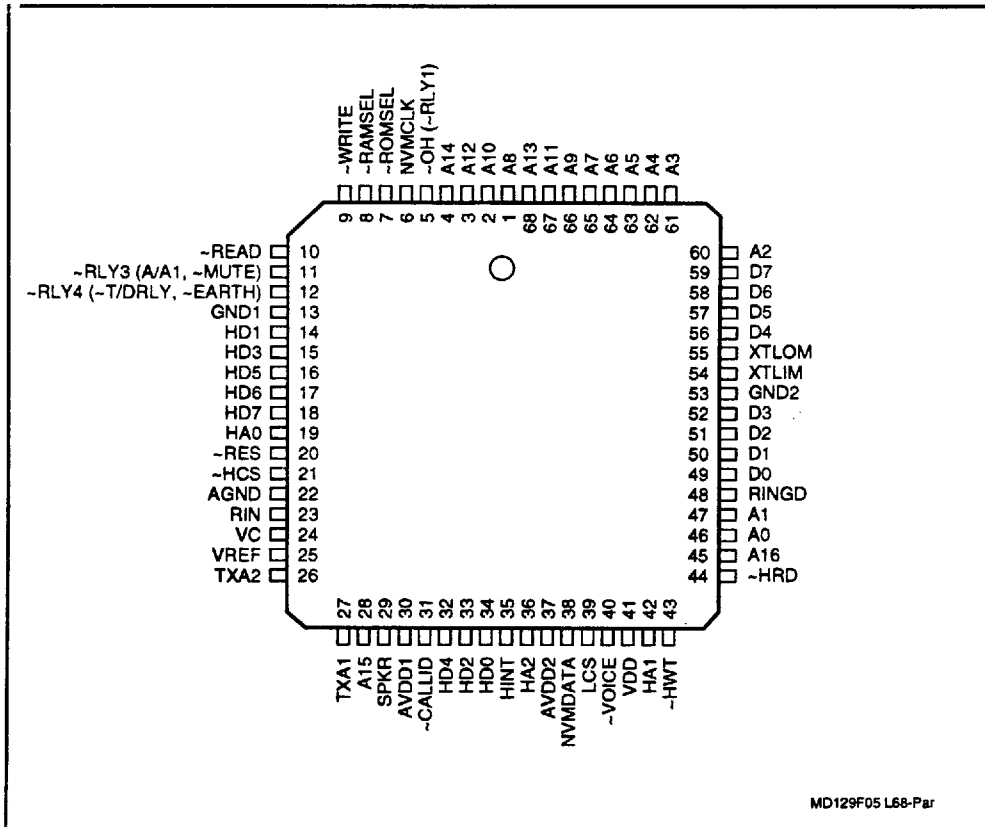

Figure 5. Pin Signals - 68-Pin PLCC - Parallel Interface

**Table 5. Pin Signals - 68-Pin PLCC - Serial Interface**

Pin	Signal Label	I/O Type	Interface	Pin	Signal Label	I/O Type	Interface
1	A8	OA	EB: A8	35	(PB7) NC		NC
2	A10	OA	EB: A10	36	(PD2) -TXD	IA	DTE: -TXD
3	A12	OA	EB: A12	37	AVDD2	PWR	VCC through power decoupling circuit
4	A14	OA	EB: A14	38	(PA1) NVMDATA <sup>4</sup>	IA/OA	NVRAM: SDA
5	(PE0) -OH (-RLY1)	OA	DAA: -OH	39	(PE4) LCS	IA	DAA: LCS <sup>5</sup>
6	(PA7) NVMCLK	OA	NVRAM: SCL	40	-VOICE	OD	DAA: -VOICE
7	(PB2) -ROMSEL	OA	ROM: -CE	41	VDD	PWR	VCC through power decoupling circuit
8	(PB3) -RAMSEL	OA	RAM: -CS	42	(PD1) -RXD	OA	DTE: -RXD
9	-WRITE	OA	EB: -WRITE	43	(PD5) NC		NC
10	-READ	OA	EB: -READ	44	(PD6) -RTS	IA	DTE: -RTS
11	(PE2) -RLY3	OA	DAA: A/A1, -MUTE	45	A16	OA	EB: A16
12	(PE3) -RLY4	OA	DAA: -T/DRLY, -EARTH	46	A0	OA	EB: A0
13	GND1	GND		47	A1	OA	EB: A1
14	(PC1) -CTS	OA	DTE: -CTS	48	(PA0) RINGD	IA	DAA: RINGD
15	(PC3) NC		NC	49	D0	IA/OA	EB: D0
16	(PC5) -RI	OA	DTE: -RI	50	D1	IA/OA	EB: D1
17	(PC6) -TM	OA	DTE: -TM	51	D2	IA/OA	EB: D2
18	(PC7) NC		NC	52	D3	IA/OA	EB: D3
19	(PD0) NC		NC	53	GND2	GND	GND
20	-RES	IC	Reset Circuit	54	XTLIM	I	Crystal Circuit
21	(PD4) -DTR	IA	DTE: -DTR	55	XTL0M	O	Crystal Circuit
22	AGND	GND	GND	56	D4	IA/OA	EB: D4
23	RIN	I(DA)	DAA: RIN	57	D5	IA/OA	EB: D5
24	VC	MI	AGND through capacitors	58	D6	IA/OA	EB: D6
25	VREF	MI	VC through capacitors	59	D7	IA/OA	EB: D7
26	TXA2	O(DD)	DAA: TXA2	60	A2	OA	EB: A2
27	TXA1	O(DD)	DAA: TXA1	61	A3	OA	EB: A3
28	A15	OA	EB: A15	62	A4	OA	EB: A4
29	SPKR	O(DF)	Speaker Circuit	63	A5	OA	EB: A5
30	AVDD1	PWR	VCC through power decoupling circuit	64	A6	OA	EB: A6
31	-CALLID	OD	DAA: -CALLID	65	A7	OA	EB: A7
32	(PC4) NC		NC	66	A9	OA	EB: A9
33	(PC2) -RLSD	OA	DTE: -RLSD	67	A11	OA	EB: A11
34	(PC0) -DSR	OA	DTE: -DSR	68	A13	OA	EB: A13

**Notes:**

- I/O types:  
 MI = Modem interconnect.  
 IA, IB = Digital input.  
 OA, OB, OD = Digital output.  
 I(DA) = Analog input.  
 O(DD), O(DF) = Analog output.
- NC = No external connection allowed.
- NU = Not used; connect as noted.
- Connect to VCC through 20K ohms.
- Connect to GND through 20K ohms.

Table 6. Pin Signals- 68-Pin PLCC - Parallel Interface

Pin	Signal Label	I/O Type	Interface	Pin	Signal Label	I/O Type	Interface
1	A8	OA	EB: A8	35	(PB7) HINT	OA	HB: HINT
2	A10	OA	EB: A10	36	(PD2) HA2	IA	HB: HA2
3	A12	OA	EB: A12	37	AVDD2	PWR	VCC through power decoupling circuit
4	A14	OA	EB: A14	38	(PA1) NVMDATA <sup>4</sup>	IA/OA	NVRAM: SDA
5	(PE0) -OH (-RLY1)	OA	DAA: -OH	39	(PE4) LCS	IA	DAA: LCS <sup>5</sup>
6	(PA7) NVMCLK	OA	NVRAM: SCL	40	-VOICE	OD	DAA: -VOICE
7	(PB2) -ROMSEL	OA	ROM: -CE	41	VDD	PWR	VCC through power decoupling circuit
8	(PB3) -RAMSEL	OA	RAM: -CS	42	(PD1) HA1	IA	HB: HA1
9	-WRITE	OA	EB: -WRITE	43	(PD5) -HWT	IA	HB: -HWT
10	-READ	OA	EB: -READ	44	(PD6) -HRD	IA	HB: -HRD
11	(PE2) -RLY3	OA	DAA: A/A1, -MUTE	45	A16	OA	EB: A16
12	(PE3) -RLY4	OA	DAA: -T/DRLY, -EARTH	46	A0	OA	EB: A0
13	GND1	GND	GND	47	A1	OA	EB: A1
14	(PC1) HD1	IA/OA	HB: HD1	48	(PA0) RINGD	IA	DAA: RINGD
15	(PC3) HD3	IA/OA	HB: HD3	49	D0	IA/OA	EB: D0
16	(PC5) HD5	IA/OA	HB: HD5	50	D1	IA/OA	EB: D1
17	(PC6) HD6	IA/OA	HB: HD6	51	D2	IA/OA	EB: D2
18	(PC7) HD7	IA/OA	HB: HD7	52	D3	IA/OA	EB: D3
19	(PD0) HA0	IA	HB: HA0	53	GND2	GND	GND
20	-RES	IC	HB: RESET through inverter	54	XTLIM	I	Crystal Circuit
21	(PD4) -HCS	IA	HB: -CS	55	XTLOM	O	Crystal Circuit
22	AGND	GND	GND	56	D4	IA/OA	EB: D4
23	RIN	I(DA)	DAA: RIN	57	D5	IA/OA	EB: D5
24	VC	MI	AGND through capacitors	58	D6	IA/OA	EB: D6
25	VREF	MI	VC through capacitors	59	D7	IA/OA	EB: D7
26	TXA2	O(DD)	DAA: TXA2	60	A2	OA	EB: A2
27	TXA1	O(DD)	DAA: TXA1	61	A3	OA	EB: A3
28	A15	OA	EB: A15	62	A4	OA	EB: A4
29	SPKR	O(DF)	Speaker Circuit	63	A5	OA	EB: A5
30	AVDD1	PWR	VCC through power decoupling circuit	64	A6	OA	EB: A6
31	-CALLID	OD	DAA: -CALLID	65	A7	OA	EB: A7
32	(PC4) HD4	IA/OA	HB: HD4	66	A9	OA	EB: A9
33	(PC2) HD2	IA/OA	HB: HD2	67	A11	OA	EB: A11
34	(PC0) HD0	IA/OA	HB: HD0	68	A13	OA	EB: A13

**Notes:**

## 1. I/O types:

MI = Modem interconnect.

IA, IB = Digital input.

OA, OB, OD = Digital output.

I(DA) = Analog input.

O(DD), O(DF) = Analog output.

## 2. NC = No external connection allowed.

## 3. NU = Not used; connect as noted.

## 4. Connect to VCC through 20K ohms.

## 5. Connect to GND through 20K ohms.

Table 7. Signal Definitions

Label	I/O Type	Signal Name/Description
<b>SYSTEM OVERHEAD</b>		
XTLIM, XTLOM	I, O	<b>Modem Data Pump Crystal In and Crystal Out.</b> Connect to an external crystal circuit consisting of a 35.251200 MHz crystal, three capacitors, and an inductor, or to a square wave generator/sine wave oscillator.
~RES	IC	<b>MCU Reset.</b> The active low ~RES input resets the MCU logic, and restores the saved configuration from NVRAM or returns the modem to the factory default values if NVRAM is not present. For serial Interface, the ~RES input is typically connected to a reset switch circuit. For parallel Interface, the ~RES input is typically connected to the host bus RESET line through an inverter. ~RESET low holds the modem in the reset state. ~RESET going high releases the modem from the reset state and initiates normal operation using power turn-on (default) values. ~RESET must be held low for at least 3 $\mu$ s. The modem is ready to use 400 ms after the low-to-high transition of ~RESET.
VCC	PWR	<b>+ 5V Digital Supply.</b> +5V $\pm$ 5%.
AVDD1	PWR	<b>IA Digital Circuits Voltage 1.</b> Connect to VCC.
AVDD2	PWR	<b>IA Digital Circuits Voltage 2</b> Connect to VCC through RC filter.
VC	MI	<b>Centerpoint Voltage.</b> Connect to analog ground through 10 $\mu$ F (polarized, + terminal to VC) and 0.1 $\mu$ F (ceramic) in parallel.
VREF	MI	<b>Voltage Reference.</b> Connect to VC through 10 $\mu$ F (polarized, + terminal to VREF) and 0.1 $\mu$ F (ceramic) in parallel.
GND1-GND2	GND	<b>Digital Ground.</b> Connect to ground.
AGND	GND	<b>Analog Ground.</b> Connect to ground.
<b>EXTERNAL MEMORY BUS INTERFACE</b>		
A0-A16	OA	<b>Address Lines 0-16.</b> A0-A16 are the external memory bus address lines.
D0-D7	IA/OA	<b>Data Line 0-7.</b> D0-D7 are the external memory bus bidirectional data lines.
~READ	OA	<b>Read Enable.</b> ~RD output low enables data transfer from the selected device to the D0-D7 lines.
~WRITE	OA	<b>Write Enable.</b> ~WRITE output low enables data transfer from the D0-D7 lines to the selected device.
~RAMSEL	OA	<b>RAM Select.</b> ~RAMSEL output low selects the external 128k-byte RAM.
~ROMSEL	OA	<b>ROM Select.</b> ~ROMSEL output low selects an external 128k-byte ROM or flash ROM.
<b>NVRAM INTERFACE</b>		
NVMCLK	OA	<b>NVRAM Clock.</b> NVMCLK output high enables the NVRAM.
NVMDATA	IA/OA	<b>NVRAM Data.</b> The NVMDATA pin supplies a serial data interface to the NVRAM.

Table 7. Signal Definitions (Cont'd)

Label	I/O Type	Signal Name/Description
<b>TELEPHONE LINE INTERFACE</b>		
TXA1, TXA2	O(DF)	<b>Transmit Analog 1 and 2.</b> The TXA1 and TXA2 outputs are differential outputs 180 degrees out of phase with each other. Each output can drive a 300 $\Omega$ load.
RIN	I(DA)	<b>Receive Analog.</b> RIN is a single-ended receive data input from the telephone line interface or an optional external hybrid circuit.
RINGD	IA	<b>Ring Detect.</b> The RINGD input is monitored for pulses in the range of 15 Hz to 68 Hz. The circuit driving RINGD should be a 4N35 optoisolator or equivalent. The circuit driving RINGD should not respond to bursts or less than 40 VRMS (15 Hz to 68 Hz) across TIP and RING. Detected ring signals are reflected on the $\sim$ RI output signal as well as the RI bit.
$\sim$ OH	OA	<b>Off-Hook Relay Control.</b> The active low $\sim$ OH output can be used to control the normally open off-hook relay. The $\sim$ PULSE function can alternatively be provided on this line in addition to the $\sim$ OH function for single $\sim$ OH/ $\sim$ PULSE relay application.
LCS	IA	<b>Loop Current Sense.</b> LCS is an active high input that indicates a handset off-hook status.
$\sim$ CALLID	OD	<b>Caller ID Relay Control.</b> For Caller ID application, the $\sim$ CALLID output is connected to the normally closed Caller ID relay (DPDT). When Caller ID is enabled, the modem will assert this output to open the Caller ID relay and close the off-hook relay in order to detect Caller ID information between the first and second rings.  The $\sim$ CALLID output can each directly drive a +5V reed relay coil with a minimum resistance of 360 ohms and having a must-operate voltage of no greater than 4.0 Vdc. A clamp diode, such as a 1N4148, should be installed across the relay coil. An external transistor, such as an MPSA20, can be used to drive heavier loads (e.g., electro-mechanical relays).
$\sim$ VOICE	OD	<b>Voice Relay Control.</b> For voice application, the $\sim$ VOICE output is connected to the normally open Voice relay (DPDT). In voice mode, $\sim$ VOICE active closes the relay to switch the handset from the telephone line to a current source to power the handset so it can be used as a microphone and speaker interface to the modem.  The $\sim$ VOICE output can each directly drive a +5V reed relay coil with a minimum resistance of 360 ohms and having a must-operate voltage of no greater than 4.0 Vdc. A clamp diode, such as a 1N4148, should be installed across the relay coil. An external transistor, such as an MPSA20, can be used to drive heavier loads (e.g., electro-mechanical relays).
$\sim$ RLY3	OA	<b>Relay 3 Control (<math>\sim</math>A/A1, <math>\sim</math>MUTE).</b> The active low $\sim$ RLY3 output can be used to control the normally open key telephone hold indicator (A/A1) relay. In W-class, $\sim$ RLY3 output can be used to control the normally open mute relay.
$\sim$ RLY4	OA	<b>Relay 4 Control (<math>\sim</math>T/DRLY, <math>\sim</math>EARTH).</b> The active low $\sim$ RLY4 output can be used to control the normally closed talk/data relay. In W-class, $\sim$ RLY4 output can be used to control the normally open earthing relay.
<b>SPEAKER INTERFACE</b>		
SPKR	O(DF)	<b>Speaker Analog Output.</b> The SPKR output reflects the received analog input signal. The SPKR is controlled by the ATMn command. The SPKR output can drive an impedance as low as 300 ohms. In a typical application, the SPKR output is an input to an external LM386 audio power amplifier.

**Table 7. Signal Definitions (Cont'd)**

Label	I/O Type	Signal Name/Description
<b>PARALLEL HOST INTERFACE (PARALLEL INTERFACE VERSION)</b>		
The parallel interface emulates a 16550A UART interface. The parallel interface is compatible with communications software designed to operate with a 16550A interface.		
HA0-HA2	IA	<b>Host Bus Address Lines 0-2.</b> During a host read or write operation with $\sim$ HCS low, HA0-HA2 select an internal MCU 16550A-compatible register.
HD0-HD7	IA/OA	<b>Host Bus Data Lines 0-7.</b> HD0-HD7 are comprised of eight three-state input/output lines providing bidirectional communication between the host and the MCU. Data, control words, and status information are transferred over HD0-HD7.
$\sim$ HCS	IA	<b>Host Bus Chip Select.</b> $\sim$ HCS input low selects the host bus.
$\sim$ HRD	IA	<b>Host Bus Read.</b> $\sim$ HRD is an active low, read control input. When $\sim$ HCS is low, $\sim$ HRD low allows the host to read status information or data from a selected MCU register.
$\sim$ HWT	IA	<b>Host Bus Write.</b> $\sim$ HWT is an active low, write control input. When $\sim$ HCS is low, $\sim$ HWT low allows the host to write data or control words into a selected MCU register.
HINT	OA	<b>Host Bus Interrupt.</b> HINT output is set high when the receiver error flag, received data available, transmitter holding register empty, or modem status interrupt is asserted. HINT is reset low upon the appropriate interrupt service or master reset operation.
<b>V.24 (EIA-232-D) SERIAL INTERFACE AND INDICATOR CIRCUIT (SERIAL INTERFACE VERSION)</b>		
These signals correspond functionally to V.24/EIA/TIA-232-E signals with TTL levels and are inverted from V.24/EIA/TIA-232-E levels.		
$\sim$ TXD	IA	<b>Transmitted Data (EIA BA/CCITT CT103).</b> The DTE uses the $\sim$ TXD line to send data to the modem for transmission over the telephone line or to transmit commands to the modem.
$\sim$ RXD	OA	<b>Received Data (EIA BB/CCITT CT 104).</b> The modem uses the $\sim$ RXD line to send data received from the telephone line to the DTE and to send modem responses to the DTE. During command mode, $\sim$ RXD data represents the modem responses to the DTE.
$\sim$ CTS	OA	<b>Clear To Send (EIA CB/CCITT CT106).</b> $\sim$ CTS output ON (low) indicates that the DTE is ready to accept data from the DTE. In asynchronous operation, in error correction or normal mode, $\sim$ CTS is always ON (low) unless RTS/CTS flow control is selected by the &Kn command.
$\sim$ DSR	OA	<b>Data Set Ready (EIA CC/CCITT CT107).</b> $\sim$ DSR indicates modem status to the DTE. $\sim$ DSR OFF (high) indicates that the DTE is to disregard all signals appearing on the interchange circuits except Ring Indicator ( $\sim$ RI). $\sim$ DSR output is controlled by the AT&Sn command.
$\sim$ RLSD	OA	<b>Received Line Signal Detector (EIA CF/CCITT CT109).</b> When AT&C0 command is not in effect, $\sim$ RLSD output is ON when a carrier is detected on the telephone line or OFF when carrier is not detected.
$\sim$ TM	OA	<b>Test Mode Indicate (EIA TM/CCITT CT142).</b> The $\sim$ TM output indicates the modem is in test mode (low) or in any other mode (high).
$\sim$ RI	OA	<b>Ring Indicator (EIA CE/CCITT CT125).</b> $\sim$ RI output ON (low) indicates the presence of an ON segment of a ring signal on the telephone line.
$\sim$ DTR	IA	<b>Data Terminal Ready (EIA CD/CCITT CT108).</b> The $\sim$ DTR input is turned ON (low) by the DTE when the DTE is ready to transmit or receive data. $\sim$ DTR ON prepares the modem to be connected to the telephone line, and maintains the connection established by the DTE (manual answering) or internally (automatic answering). $\sim$ DTR OFF places the modem in the disconnect state under control of the &Dn and &Qn commands.
$\sim$ RTS	IA	<b>Request To Send (EIA CA/CCITT CT105).</b> $\sim$ RTS input ON (low) indicates that the DTE is ready to accept data from the modem. In the command state, the modem ignores $\sim$ RTS. In asynchronous operation, the modem ignores $\sim$ RTS unless RTS/CTS flow control is selected by the &Kn command.

Table 8. Digital Electrical Characteristics

Parameter	Symbol	Min.	Typ.	Max.	Units	Test Conditions <sup>1</sup>
Input High Voltage	$V_{IH}$				VDC	
Type IA		2.0	–	$V_{CC}$		
Type IC		$0.7 V_{CC}$	–	$V_{CC} + 0.3$		
Type IE		–	4.0	–		Note 2.
Input Low Voltage	$V_{IL}$				VDC	
Type IA and 1C		–0.3		0.8		
Type IE		–	1.0	–		Note 2.
Input High Current	$I_{IH}$			40	$\mu A$	$V_{IN} = 5.25V, V_{CC} = 5.25V,$
Input Low Current	$I_{IL}$			400	$\mu A$	$V_{CC} = 5.25V$
Input Leakage Current	$I_{IN}$				$\mu ADC$	$V_{IN} = 0$ to $5V, V_{CC} = 5.25V$
–RES and PD0-PD7		–	–	$\pm 2.5$		
Type OA and OB		2.4	–	–		$I_{LOAD} = -100 \mu A$
Type OD		–	–	$V_{CC}$		$I_{LOAD} = 0 mA$
Type OE						Note 3.
Output Low Voltage	$V_{OL}$				VDC	
Type OA		–	–	0.4		$I_{LOAD} = 1.6 mA$
Type OB		–	–	0.4		$I_{LOAD} = 0.8 mA$
Type OD		–	–	0.75		$I_{LOAD} = 15 mA$
Three-State (Off) Current	$I_{TSI}$			$\pm 10$	$\mu ADC$	$V_{IN} = 0 V$ to $V_{CC}$

**Notes:**

- Test Conditions:  $V_{CC} = 5V \pm 5\%$   
 $T_A = 0^\circ C$  to  $70^\circ C$ , (unless otherwise stated).  
Output loads: Data bus (D0-D7), address bus (A0-A15), chip selects,  
–READ, and –WRITE loads =  $70 pF$  + one TTL load.  
Other =  $50 pF$  + one TTL load.
- Type IE inputs are centered approximately  $2.5 V$  and swing  $1.5 V_{PEAK}$  in each direction.
- Type OE outputs provide oscillator feedback when operating with an external crystal.

Table 9. Analog Electrical Characteristics

Name	Type	Characteristic	Value
RIN	I (DA)	Input Impedance AC Input Voltage Range Reference Voltage	$> 70K \Omega$ $1.1 VP-P^{**}$ $+2.5 VDC$
TXA1, TXA2	O (DD)	Minimum Load Maximum Capacitive Load Output Impedance AC Output Voltage Range Reference Voltage DC Offset Voltage	$300 \Omega$ $0 \mu F$ $10 \Omega$ $2.2 VP-P$ $+2.5 VDC$ $\pm 200 mV$
SPKR	O (DF)	Minimum Load Maximum Capacitive Load Output Impedance AC Output Voltage Range Reference Voltage DC Offset Voltage	$300 \Omega$ $0.01 \mu F$ $10 \Omega$ $1.1 VP-P$ $+2.5 VDC$ $\pm 20 mV$

\* Reference Voltage provided internal to the modem.

\*\* Corresponds to  $2.2 VP-P$  at Tip and Ring.

Table 10. Current and Power Requirements

Mode	Current (ID)			Power (PD)			Notes
	Typical Current @ 25°C (mA)	Maximum Current @ 0°C (mA)	Maximum Current @ -40°C <sup>1</sup> (mA)	Typical Power @ 25°C (mW)	Maximum Power @ 0°C (mW)	Maximum Power @ -40°C <sup>1</sup> (mW)	
Normal mode	170	210	235	850	1105	1135	

Notes:  
 1. Maximum power @ -40°C specified only for extended temperature range parts.  
 2. Test conditions: VCC = 5.0 VDC for typical values; VCC = 5.25 VDC for maximum values.

Table 11. Absolute Maximum Ratings

Parameter	Symbol	Limits	Units
Supply Voltage	V <sub>DD</sub>	-0.5 to +7.0	V
Input Voltage	V <sub>IN</sub>	-0.5 to (+5V <sub>D</sub> +0.5)	V
Operating Temperature Range	T <sub>A</sub>		°C
Commercial		-0 to +70	
Extended		-40 to +85	
Storage Temperature Range	T <sub>STG</sub>	-55 to +125	°C
Analog Inputs	V <sub>IN</sub>	-0.3 to (+5V <sub>A</sub> + 0.3)	V
Voltage Applied to Outputs in High Impedance (Off) State	V <sub>HZ</sub>	-0.5 to (+5V <sub>D</sub> + 0.5)	V
DC Input Clamp Current	I <sub>IK</sub>	±20	mA
DC Output Clamp Current	I <sub>OK</sub>	±20	mA
Static Discharge Voltage (25°C)	V <sub>ESD</sub>	±2500	V
Latch-up Current (25°C)	I <sub>TRIG</sub>	±200	mA

Table 12. Parallel Interface Registers

Register No.	Register Name	Bit No.							
		7	6	5	4	3	2	1	0
7	Scratch Register (SCR)	Scratch Register							
6	Modem Status Register (MSR)	Data Carrier Detect (DCD)	Ring Indicator (RI)	Data Set Ready (DSR)	Clear to Send (CTS)	Delta Data Carrier Detect (DDCD)	Trailing Edge of Ring Indicator (TERI)	Delta Data Set Ready (DDSR)	Delta Clear to Send (DCTS)
5	Line Status Register (LSR)	RX FIFO Error	Transmitter Empty (TEMT)	Transmitter Buffer Register Empty (THRE)	Break Interrupt (BI)	Framing Error (FE)	Parity Error (PE)	Overrun Error (OE)	Receiver Data Ready (DR)
4	Modem Control Register (MCR)	0	0	0	Local Loopback	Out 2	Out 1	Request to Send (RTS)	Data Terminal Ready (DTR)
3	Line Control Register (LCR)	Divisor Latch Access Bit (DLAB)	Set Break	Stick Parity	Even Parity Select (EPS)	Parity Enable (PEN)	Number of Stop Bits (STB)	Word Length Select Bit 1 (WLS1)	Word Length Select Bit 0 (WLS0)
2	Interrupt Identify Register (IIR) (Read Only)	FIFOs Enabled	FIFOs Enabled	0	0	Pending Interrupt ID Bit 2	Pending Interrupt ID Bit 1	Pending Interrupt ID Bit 0	"0" if Interrupt Pending
2	FIFO Control Register (FCR) (Write Only)	Receiver Trigger MSB	Receiver Trigger LSB	Reserved	Reserved	DMA Mode Select	TX FIFO Reset	RX FIFO Reset	FIFO Enable
1 (DLAB = 0)	Interrupt Enable Register (IER)	0	0	0	0	Enable Modem Status Interrupt (EDSSI)	Enable Receiver Line Status Interrupt (ELSI)	Enable Transmitter Holding Register Empty Interrupt (ETBEI)	Enable Received Data Available Interrupt (ERBFI)
0 (DLAB = 0)	Transmitter Buffer Register (THR)	Transmitter FIFO Buffer Register (Write Only)							
0 (DLAB = 0)	Receiver Buffer Register (RBR)	Receiver FIFO Buffer Register (Read Only)							
1 (DLAB = 1)	Divisor Latch MSB Register (DLM)	Divisor Latch MSB							
0 (DLAB = 1)	Divisor Latch LSB Register (DLL)	Divisor Latch LSB							

**SCHEMATICS**

A typical interface schematic to the serial DTE interface is shown in Figure 6.

A typical interface schematic to the parallel host interface is shown in Figure 7.

A schematic for a typical line interface circuit is shown in Figure 8.

Figure 9 is a schematic of a typical external hybrid circuit.

A schematic for a typical speaker circuit connected to the SPKR output is shown in Figure 10.

Consult applicable AccelerATor Kits or Reference Designs for full schematics of typical applications.

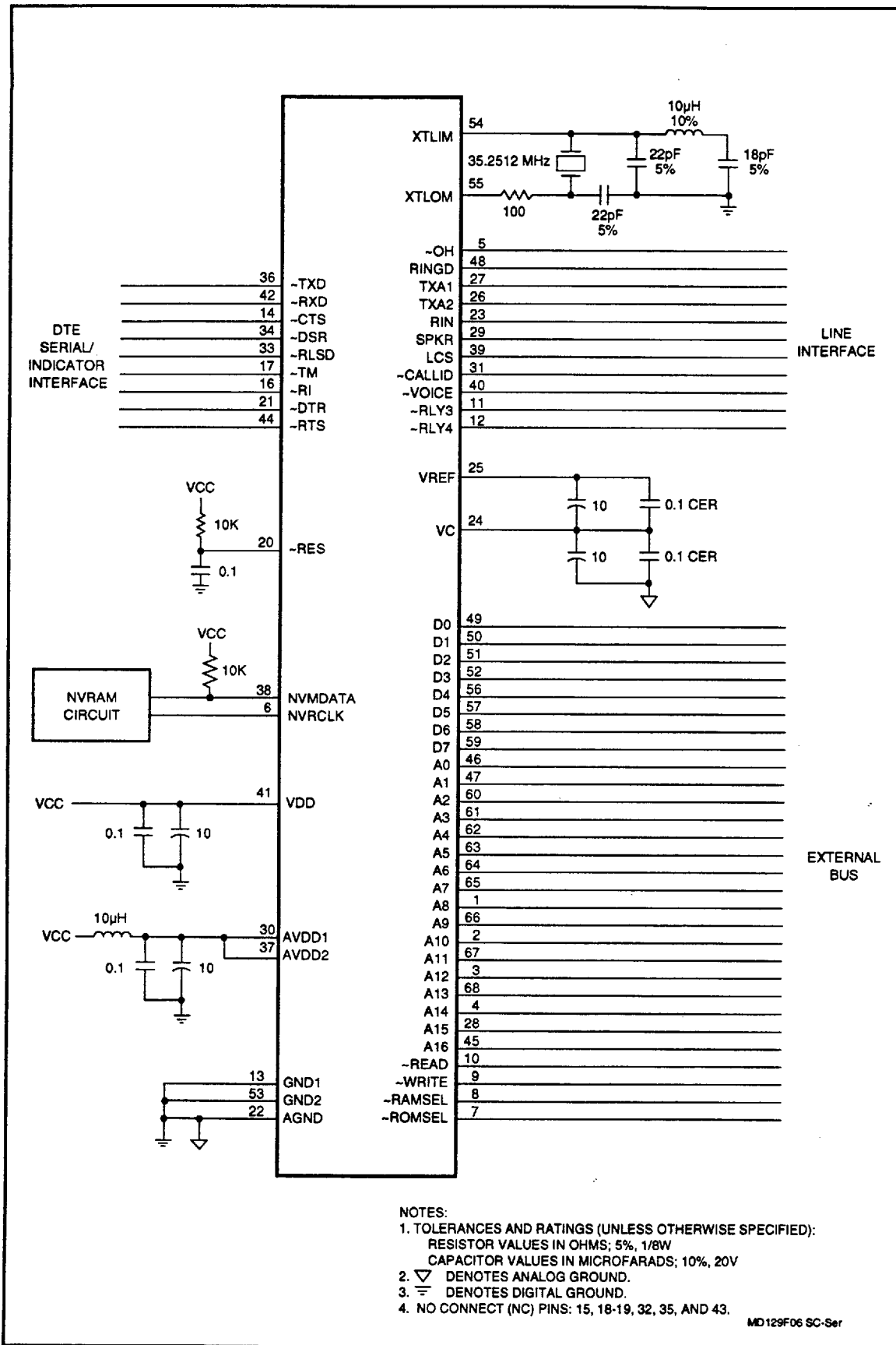

Figure 6. Interface Schematic - Serial DTE Interface

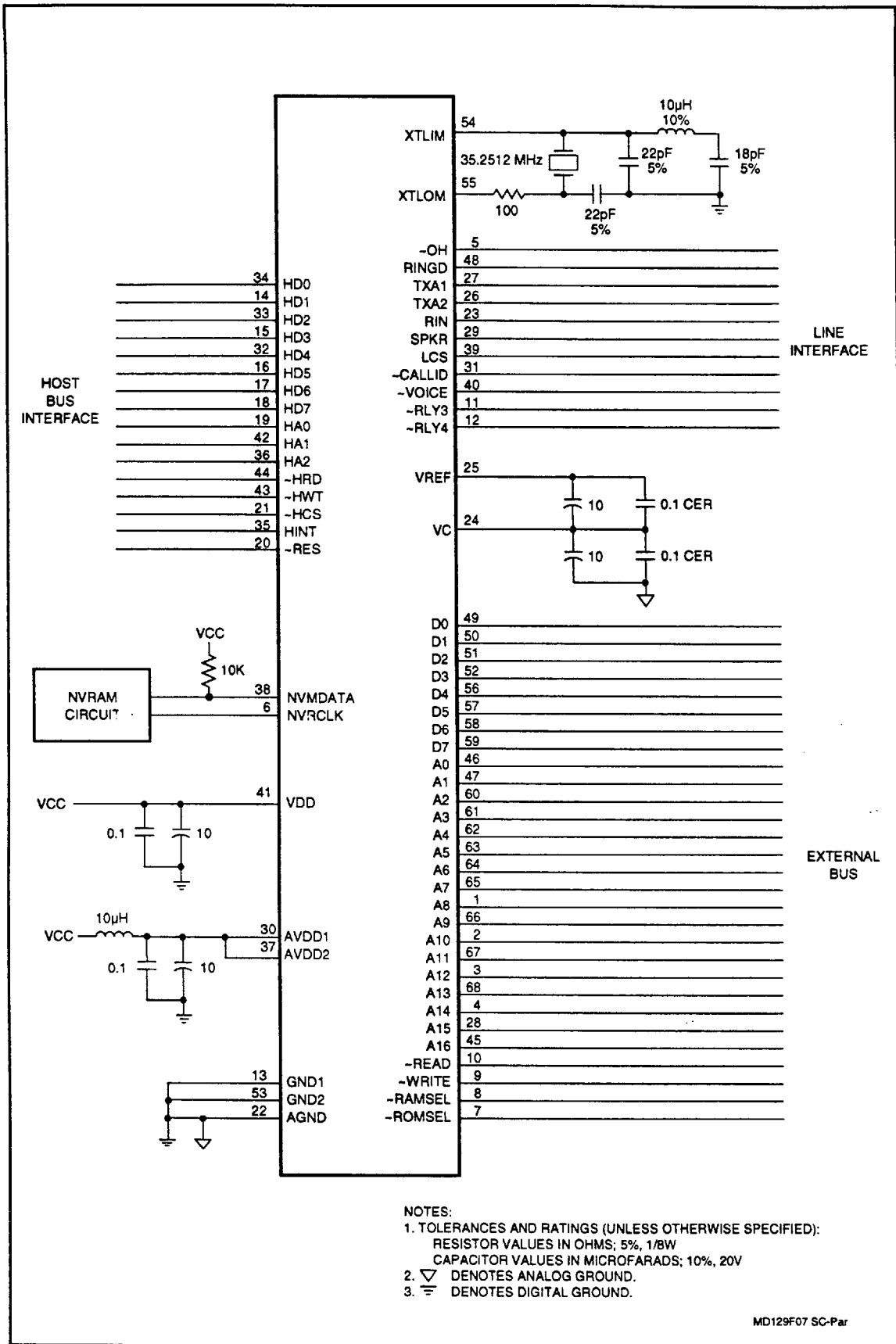

Figure 7. Interface Schematic - Parallel Host Interface

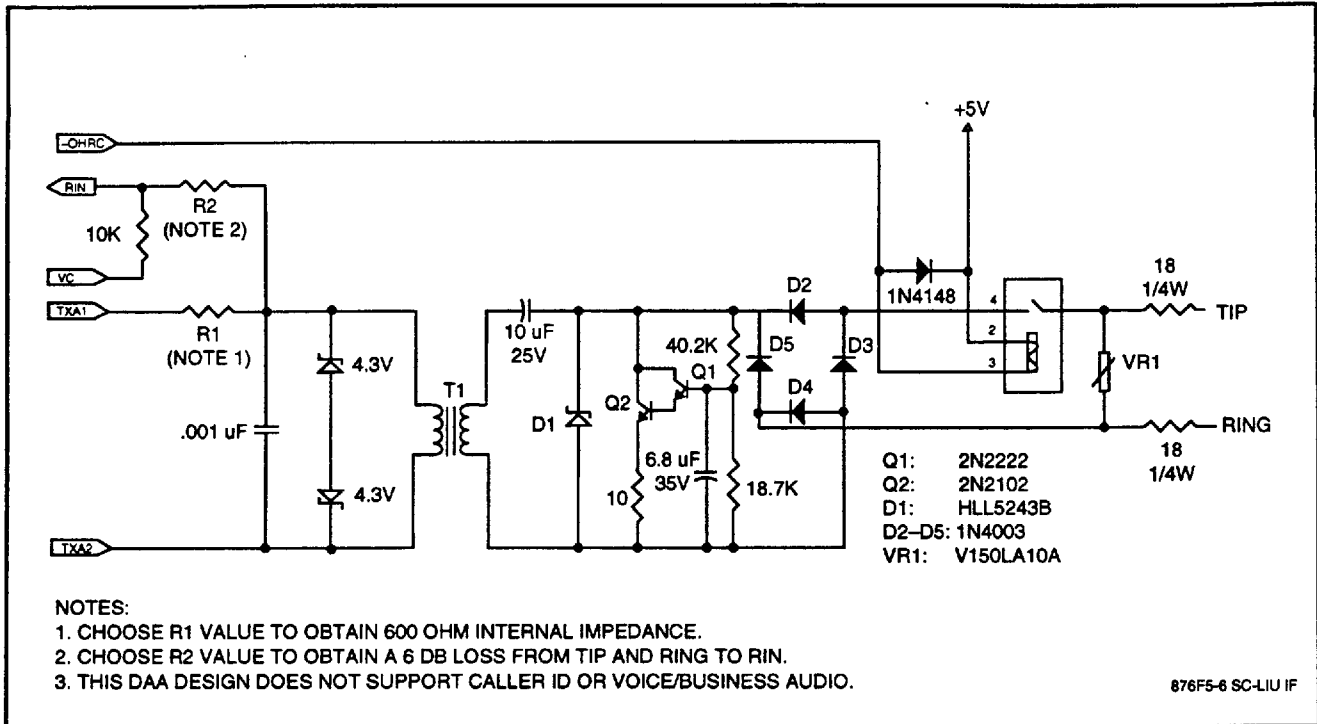

Figure 8. Typical Line Interface

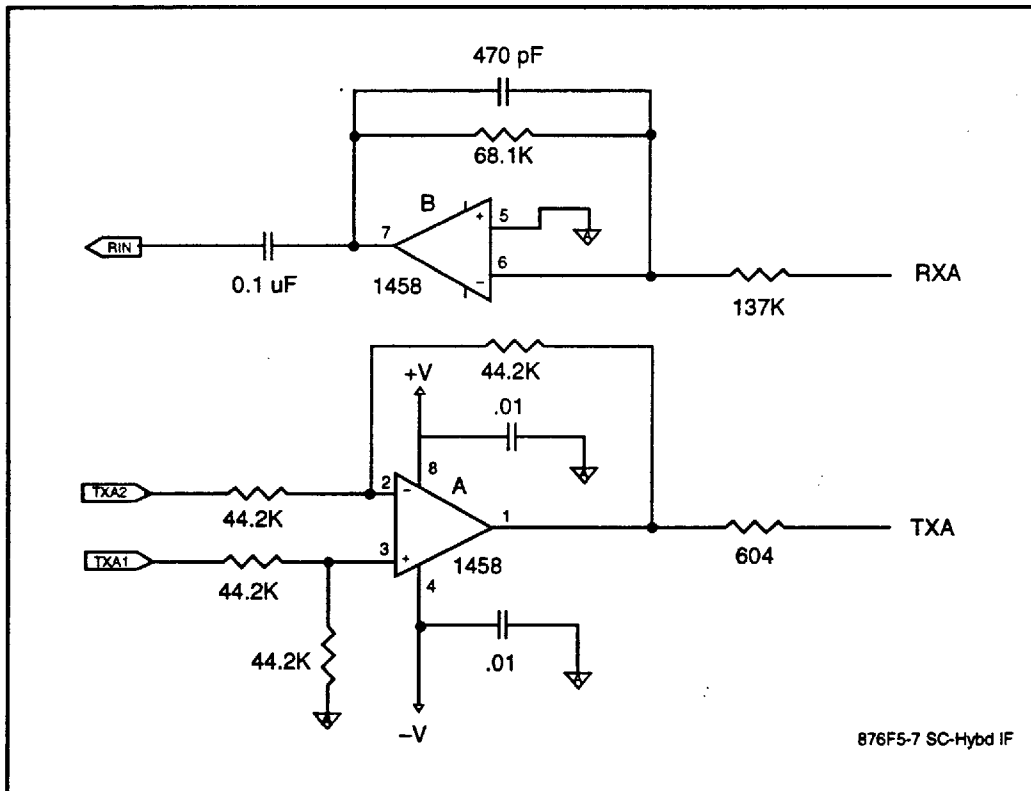

Figure 9. Typical Interface to External Hybrid

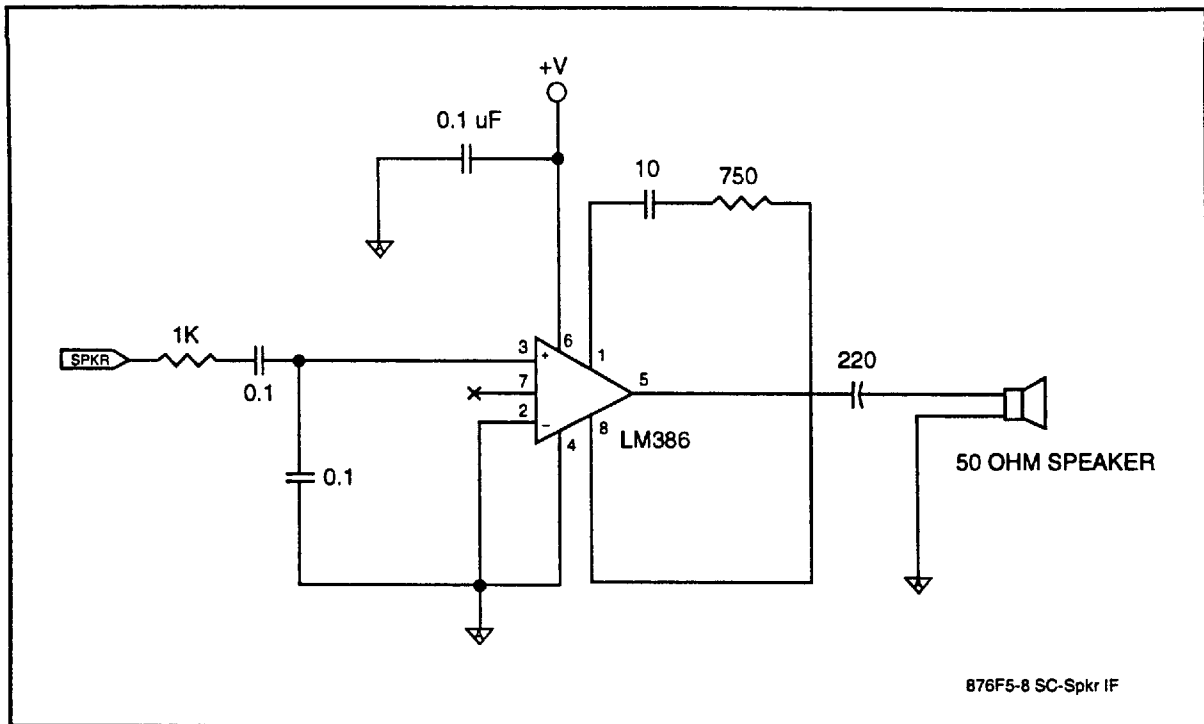

Figure 10. Typical External Speaker Circuit

**PACKAGE DIMENSIONS**

The package dimensions are shown in Figure 11.

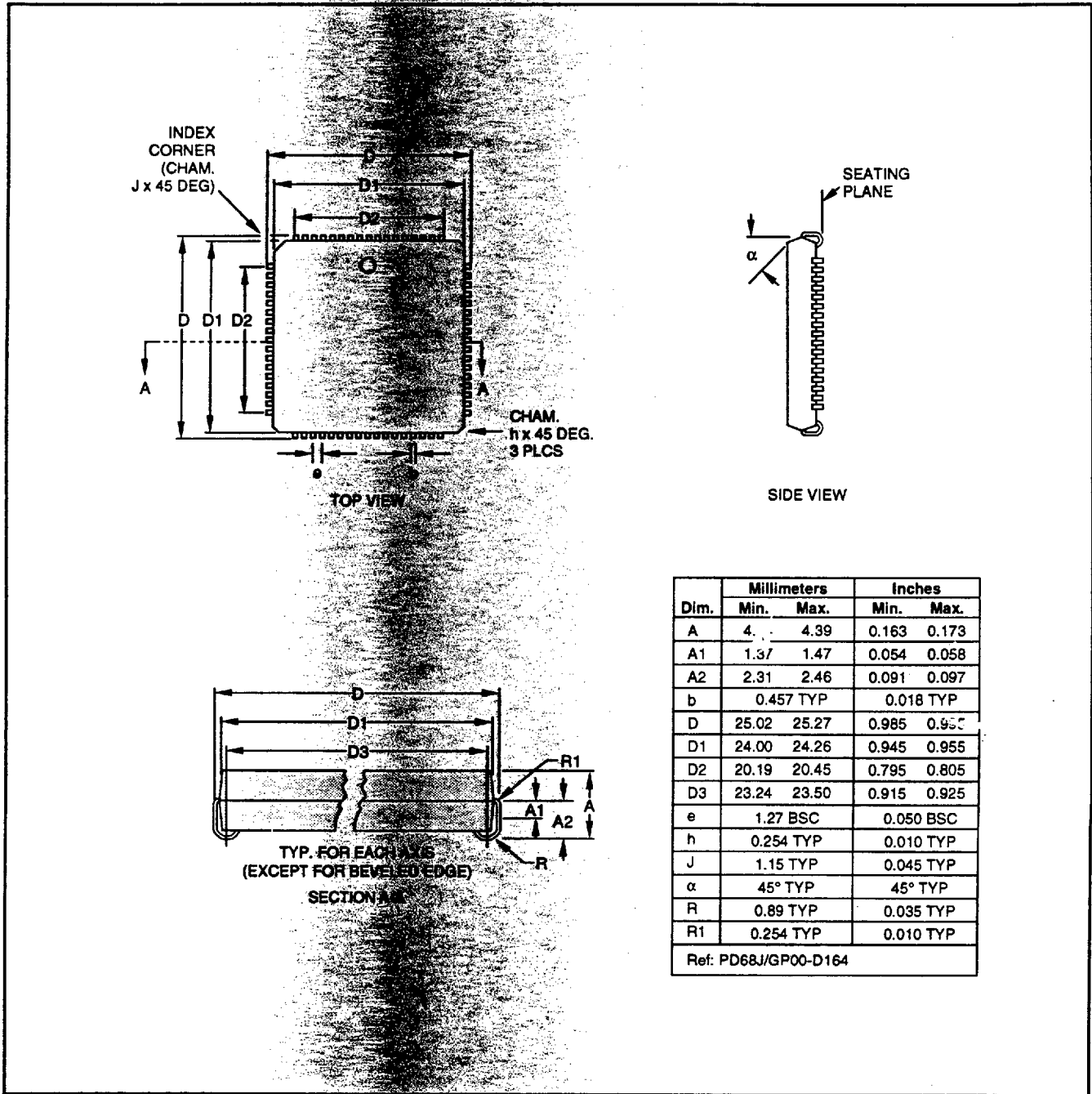

Figure 11. Package Dimensions - 68-Pin PLCC