

ML2281, ML2282, ML2284, ML2288

Serial I/O 8-Bit A/D Converters with Multiplexer Options

GENERAL DESCRIPTION

The ML2281 family are 8-bit successive approximation A/D converters with serial I/O and configurable input multiplexers with up to 8 input channels.

All errors of the sample-and-hold, incorporated on the ML2281 family are accounted for in the analog-to-digital converters accuracy specification.

The voltage reference can be externally set to any value between GND and V_{CC} , thus allowing a full conversion over a relatively small voltage span if desired.

The ML2281 family is an enhanced double polysilicon CMOS pin compatible second source for the ADC0831, ADC0832, ADC0834, and ADC0838 A/D converters. The ML2281 series enhancements are faster conversion time, true sample-and-hold function, superior power supply rejection, improved AC common mode rejection, faster digital timing, and lower power dissipation. All parameters are guaranteed over temperature with a power supply voltage of $5V \pm 10\%$.

FEATURES

- Conversion time: $6\mu s$
- Total unadjusted error: $\pm 1/2LSB$ or $\pm 1LSB$
- Sample-and-hold: 375ns acquisition
- 2, 4 or 8-input multiplexer options
- 0 to 5V analog input range with single 5V power supply
- Operates ratiometrically or with up to 5V voltage reference
- No zero or full-scale adjust required
- ML2281 capable of digitizing a 5V, 40kHz sine wave
- Low power: 12.5mW MAX
- Superior pin compatible replacement for ADC0831, ADC0832, ADC0834, and ADC0838
- Analog input protection: 25mA (min) per input
- Now in 8-Pin SOIC Package (ML2281, ML2282)

BLOCK DIAGRAM

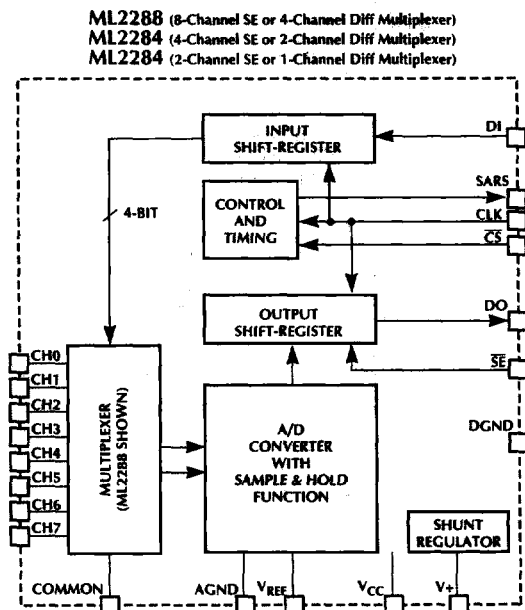
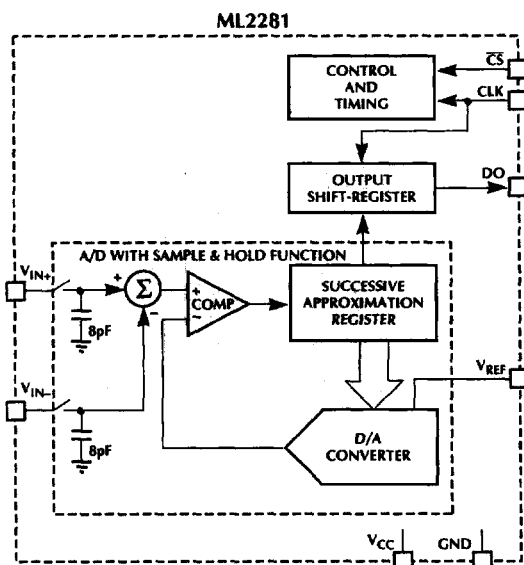

ML2281, ML2282, ML2284, ML2288

PIN CONFIGURATION

ML2281
Single Differential Input
8-Pin DIP

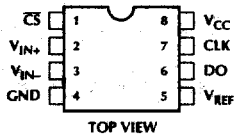

ML2282
2-Channel MUX
8-Pin DIP

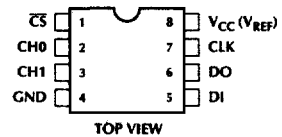

ML2281
8-Pin SOIC

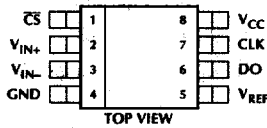

ML2282
8-Pin SOIC

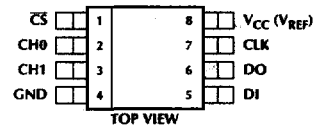

ML2284
14-Pin SOIC

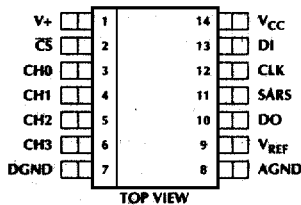

ML2284
4-Channel MUX
14-Pin DIP

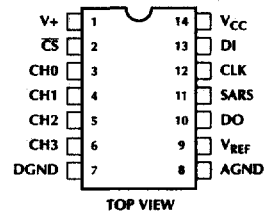

ML2288
8-Channel MUX
20-Pin PCC

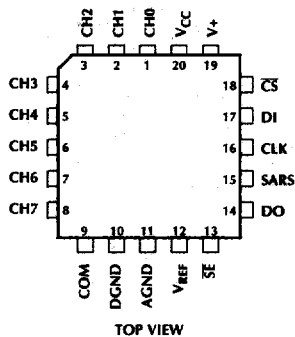

ML2288
8-Channel MUX
20-Pin DIP

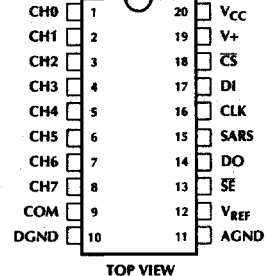

PIN DESCRIPTION

NAME	FUNCTION	NAME	FUNCTION
V _{CC}	Positive supply. 5V ± 10%	DO	Data out. Digital output which contains result of A/D conversion. The serial data is clocked out on falling edges of CLK.
DGND	Digital ground. 0 volts. All digital inputs and outputs are referenced to this point.	SARS	Successive approximation register status. Digital output which indicates that a conversion is in progress. When SARS goes to 1, the sampling window is closed and conversion begins. When SARS goes to 0, conversion is completed. When $\overline{CS} = 1$, SARS is in high impedance state.
AGND	Analog ground. The negative reference voltage for A/D converter.	CLK	Clock. Digital input which clocks data in on DI on rising edges and out on DO on falling edges. Also used to generate clocks for A/D conversion.
CH0-7, V _{IN+} , V _{IN-}	Analog inputs. Digitally selected to be single ended (V _{IN}) or; V _{IN+} or V _{IN-} of a differential input. Analog range = $GND \leq V_{IN} \leq V_{CC}$.	DI	Data input. Digital input which contains serial data to program the MUX and channel assignments.
COM	Common reference point for analog inputs. A/D conversion is performed on voltage difference between analog input and this common reference point if single-end conversion is specified.	\overline{CS}	Chip select. Selects the chip for multiplexer and channel assignment and A/D conversion. When $\overline{CS} = 1$, all digital outputs are in high impedance state. When $\overline{CS} = 0$, normal A/D conversion takes place.
V _{REF}	Reference. The positive reference voltage for A/D converter.		
\overline{SE}	Shift enable. Input controls whether LSB first bit stream is shifted out on serial output DO. If $\overline{SE} = 1$, MSB first is shifted out only. If $\overline{SE} = 0$, an MSB first bit stream is shifted out, then a second bit stream with LSB first is shifted out after end of conversion.		
V+	Input to the Shunt Regulator.		

ML2281, ML2282, ML2284, ML2288

ABSOLUTE MAXIMUM RATINGS

Absolute maximum ratings are those values beyond which the device could be permanently damaged. Absolute maximum ratings are stress ratings only and functional device operation is not implied.

Current into V+	15mA
Supply Voltage, V _{CC}	6.5V
Voltage	
Logic Inputs	-7 to V _{CC} +7V
Analog Inputs	-0.3V to V _{CC} +0.3V
Input Current per Pin (Note 1)	±25mA
Storage Temperature	-65°C to 150°C
Package Dissipation	
at T _A = 25°C (Board Mount)	800mW

Lead Temperature (Soldering 10 sec.)	
Dual-In-Line Package (Molded)	260°C
Dual-In-Line Package (Ceramic)	300°C
Molded Chip Carrier Package	
Vapor Phase (60 sec.)	215°C
Infrared (15 sec.)	220°C

OPERATING CONDITIONS

Supply Voltage, V _{CC}	4.5V _{DC} to 6.3V _{DC}
Temperature Range (Note 2)	T _{MIN} ≤ T _A ≤ T _{MAX}
ML2281/2/4/8 BIX	-40°C to 85°C
ML2281/2/4/8 CIX	
ML2281/2/4/8 BCX	0°C to 70°C
ML2281/2/4/8 CCX	

ELECTRICAL CHARACTERISTICS

Unless otherwise specified, T_A = T_{MIN} to T_{MAX}, V_{CC} = V_{REF} = 5V ±10%, and f_{CLK} = 1.333MHz.

SYMBOL	PARAMETER	CONDITIONS	ML228XB			ML228XC			UNITS
			MIN	TYP NOTE 3	MAX	MIN	TYP NOTE 3	MAX	
CONVERTER AND MULTIPLEXER CHARACTERISTICS									
	Total Unadjusted Error	V _{REF} = V _{CC} (Notes 4, 6)			±1/2			±1	LSB
	Reference Input Resistance	(Notes 4, 7)	10	15	20	10	15	20	kΩ
	Common-Mode Input Range	(Notes 4, 8)	GND -0.05		V _{CC} +0.05	GND -0.05		V _{CC} +0.05	V
	DC Common-Mode Error	Common mode voltage voltage GND to V _{CC/2} (Note 5)		±1/16	±1/4		±1/16	±1/4	LSB
	AC Common-Mode Error	Common mode voltage GND to V _{CC/2} , 0 to 50kHz (Note 5)			±1/4			±1/4	LSB
	DC Power Supply Sensitivity	V _{CC} = 5V ±10% V _{REF} ≤ V _{CC} +0.1V (Note 5)		±1/32	±1/4		±1/32	±1/4	LSB
	AC Power Supply Sensitivity	100mV _{P-P} , 25kHz sine on V _{CC} (Note 5)			±1/4			±1/4	LSB
	Change in Zero Error from V _{CC} =5V to Internal Zener Operation	15mA into V+ V _{CC} = N.C. V _{REF} = 5V (Note 5)		±1/2			±1/2		LSB
V _Z	Internal Diode Regulated Break-down (at V+)	15mA into V+		6.9			6.9		V
V+	Input Resistance	(Note 4)	20	35		20	35		kΩ

ML2281, ML2282, ML2284, ML2288

ELECTRICAL CHARACTERISTICS (Continued)

SYMBOL	PARAMETER	CONDITIONS	ML228XB			ML228XC			UNITS
			MIN	TYP NOTE 3	MAX	MIN	TYP NOTE 3	MAX	
CONVERTER AND MULTIPLEXER CHARACTERISTICS (CONTINUED)									
I_{OFF}	Off Channel Leakage Current	On channel = V_{CC} Off channel = 0V (Notes 4, 9)	-1			-1			μA
		On channel = 0V Off channel = V_{CC} (Notes 4, 9)			+1			+1	μA
I_{ON}	On Channel Leakage Current	On channel = 0V Off channel = V_{CC} (Notes 4, 9)	-1			-1			μA
		On channel = V_{CC} Off channel = 0V (Notes 4, 9)			+1			+1	μA
DIGITAL AND DC CHARACTERISTICS									
$V_{IN(1)}$	Logical "1" Input Voltage	(Note 4)	2.0			2.0			V
$V_{IN(0)}$	Logical "0" Input Voltage	(Note 4)			0.8			0.8	V
$I_{IN(1)}$	Logical "1" Input Current	$V_{IN} = V_{CC}$ (Note 4)			1			1	μA
$I_{IN(0)}$	Logical "0" Input Current	$V_{IN} = 0V$ (Note 4)	-1			-1			μA
$V_{OUT(1)}$	Logical "1" Output Voltage	$I_{OUT} = -2mA$ (Note 4)	4.0			4.0			V
$V_{OUT(0)}$	Logical "0" Output Voltage	$I_{OUT} = 2mA$ (Note 4)			0.4			0.4	V
I_{OUT}	HI-Z Output Current	$V_{OUT} = 0V$ (Note 4) $V_{OUT} = V_{CC}$	-1		1	-1		1	μA μA
I_{SOURCE}	Output Source Current	$V_{OUT} = 0V$ (Note 4)	-6.5			-6.5			mA
I_{SINK}	Output Sink Current	$V_{OUT} = V_{CC}$ (Note 4)			8.0			8.0	mA
I_{CC}	Supply Current	ML2281, ML2284 ML2288 (Note 4)		1.3	2.5		1.3	2.5	mA
		ML2282 Includes ladder Current (Note 4)		1.8	3.5		1.8	3.5	mA

ML2281, ML2282, ML2284, ML2288

ELECTRICAL CHARACTERISTICS (Continued)

SYMBOL	PARAMETER	CONDITIONS	MIN	TYP NOTE 3	MAX	LIMIT UNITS
AC ELECTRICAL CHARACTERISTICS						
f_{CLK}	Clock Frequency	(Note 4)	10		1.333	kHz
t_{ACQ}	Sample-and-Hold Acquisition			1/2		$1/f_{CLK}$
t_C	Conversion Time	Not including MUX addressing time		8		$1/f_{CLK}$
SNR	Signal to Noise Ratio ML2281	$V_{IN} = 40\text{kHz}$, 5V sine. $f_{CLK} = 1.333\text{MHz}$ ($f_{SAMPLING} \approx 120\text{kHz}$). Noise is sum of all nonfundamental components up to 1/2 of $f_{SAMPLING}$ (Note 11)		47		dB
THD	Total Harmonic Distortion ML2281	$V_{IN} = 40\text{kHz}$, 5V sine. $f_{CLK} = 1.333\text{MHz}$ ($f_{SAMPLING} \approx 120\text{kHz}$). THD is sum of 2, 3, 4, 5 harmonics relative to fundamental (Note 11)		-60		dB
IMD	Intermodulation Distortion ML2281	$V_{IN} = f_A + f_B$. $f_A = 40\text{kHz}$, 2.5V sine. $f_B = 39.8\text{kHz}$, 2.5V Sine, $f_{CLK} = 1.333\text{MHz}$ ($f_{SAMPLING} \approx 120\text{kHz}$). IMD is $(f_A + f_B)$, $(f_A - f_B)$, $(2f_A + f_B)$, $(2f_A - f_B)$, $(f_A + 2f_B)$, $(f_A - 2f_B)$ relative to fundamental (Note 11)		-60		dB
	Clock Duty Cycle	(Notes 4, 10)	40		60	%
t_{SET-UP}	\overline{CS} Falling Edge or Data Input Valid to CLK Rising Edge	(Note 4)	130			ns
t_{HOLD}	Data Input Valid after CLK Rising Edge	(Note 4)	80			ns
t_{PD1} , t_{PD0}	CLK Falling Edge to Output Data Valid	$C_L = 100\text{pF}$ (Note 4 & 12) Data MSB first Data LSB first		90 50	200 110	ns ns
t_{1H} , t_{0H}	Rising Edge of \overline{CS} to Data Output and SARS Hi-Z	$C_L = 10\text{pF}$, $R_L = 10\text{k}$ (see high impedance test circuits) (Note 5)		40	90	ns
		$C_L = 100\text{pF}$, $R_L = 2\text{k}$ (Note 4)		80	160	ns
C_{IN}	Capacitance of Logic Input			5		pF
C_{OUT}	Capacitance of Logic Outputs			5		pF

Note 1: When the input voltage (V_{IN}) at any pin exceeds the power supply rails ($V_{IN} < GND$ or $V_{IN} > V_{CC}$) the absolute value of current at that pin should be limited to 25mA or less.

Note 2: 0°C to 70°C and -40°C to +85°C operating temperature range devices are 100% tested with temperature limits guaranteed by 100% testing, sampling, or by correlation with worst-case test conditions.

Note 3: Typicals are parametric norm at 25°C.

Note 4: Parameter guaranteed and 100% production tested.

Note 5: Parameter guaranteed. Parameters not 100% tested are not in outgoing quality level calculation.

Note 6: Total unadjusted error includes offset, full-scale, linearity, multiplexer and sample-and-hold errors.

Note 7: Cannot be tested for ML2282.

Note 8: For $V_{IN} \geq V_{IN+}$ the digital output code will be 0000 0000. Two on-chip diodes are tied to each analog input (see Block Diagram) which will forward conduct for analog input voltages one diode drop below ground or one diode drop greater than the V_{CC} supply. Be careful, during testing at low V_{CC} levels (4.5V), as high level analog inputs (5V) can cause this input diode to conduct—especially at elevated temperatures, and cause errors for analog inputs near full-scale. The spec allows 50mV forward bias of either diode. This means that as long as the analog V_{IN} or V_{REF} does not exceed the supply voltage by more than 50mV, the output code will be correct. To achieve an absolute 0V to 5V input voltage range will therefore require a minimum supply voltage of $4.950V_{DC}$ over temperature variations, initial tolerance and loading.

Note 9: Leakage current is measured with the clock not switching.

Note 10: A 40% to 60% clock duty cycle range insures proper operation at all clock frequencies. In the case that an available clock has a duty cycle outside of these limits, the minimum time the clock is high or the minimum time the clock is low must be at least 300ns. The maximum time the clock can be high or low is 60 μ s.

Note 11: Because of multiplexer addressing, test conditions for the ML2282 would be $V_{IN} = 34\text{kHz}$, 5V sine ($f_{SAMPLING} = 102\text{kHz}$); ML2284 $V_{IN} = 32\text{kHz}$, 5V sine ($f_{SAMPLING} = 95\text{kHz}$); ML2288 $V_{IN} = 30\text{kHz}$, 5V sine ($f_{SAMPLING} = 89\text{kHz}$).

Note 12: Since data, MSB first, is the output of the comparator used in the successive approximation loop, an additional delay is built in (see Block Diagram) to allow for comparator response time.

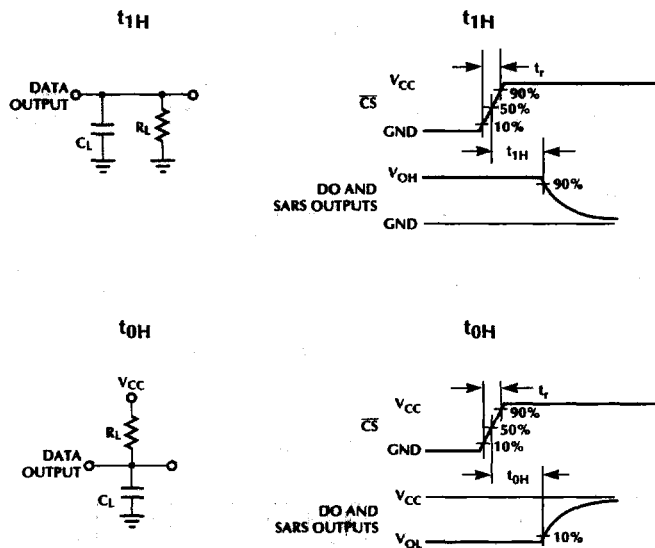
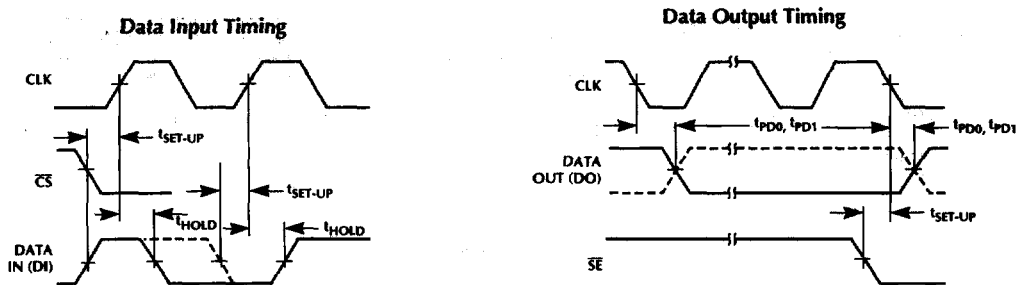

Figure 1. High Impedance Test Circuits and Waveforms



ML2281 Start Conversion Timing

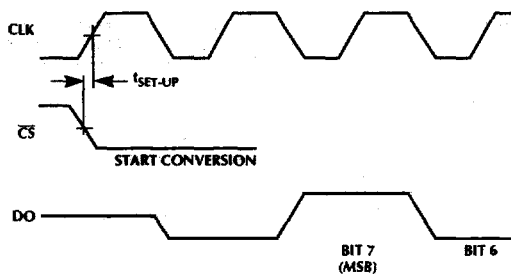
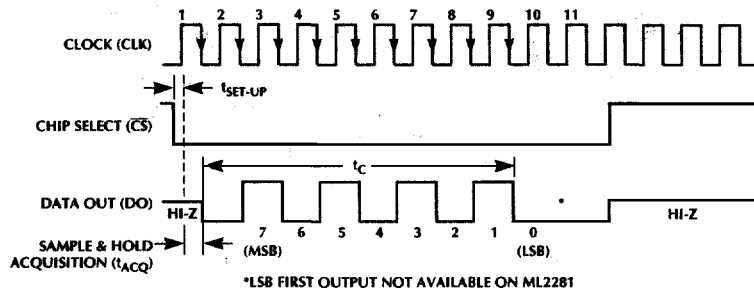
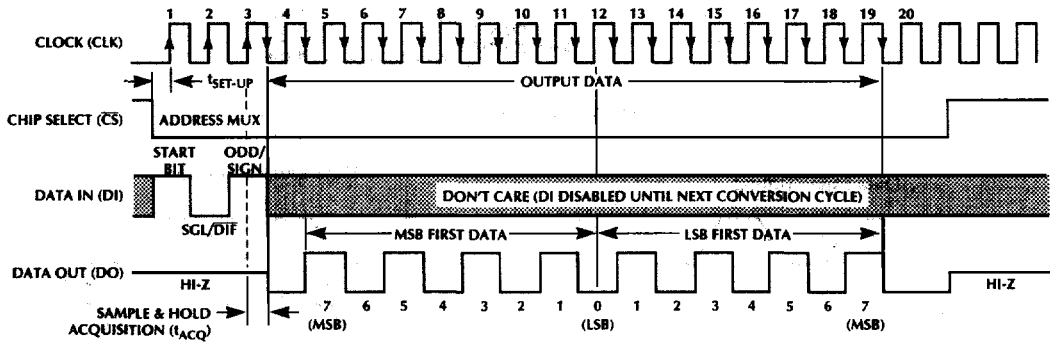

Figure 2. Timing Diagrams

ML2281 Timing



ML2282 Timing



ML2284 Timing

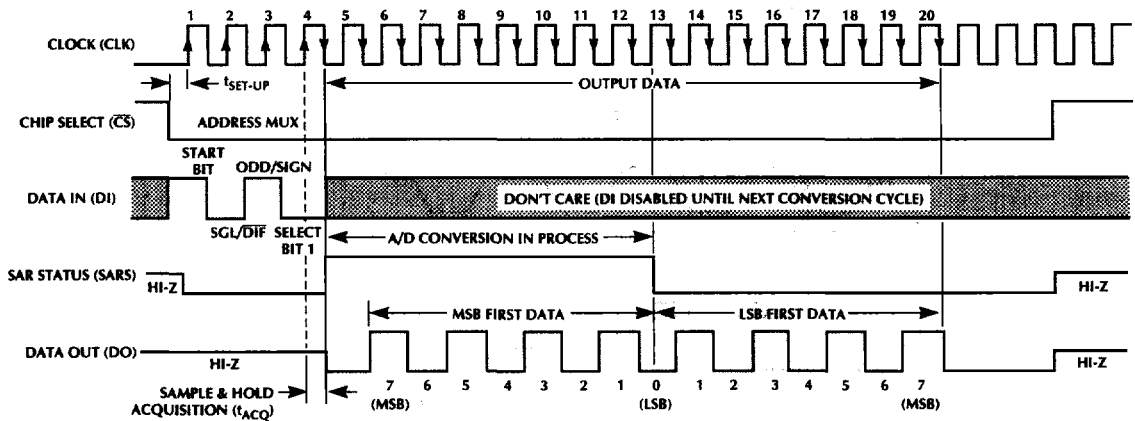

Figure 2. Timing Diagrams (Continued)

ML2288 Timing

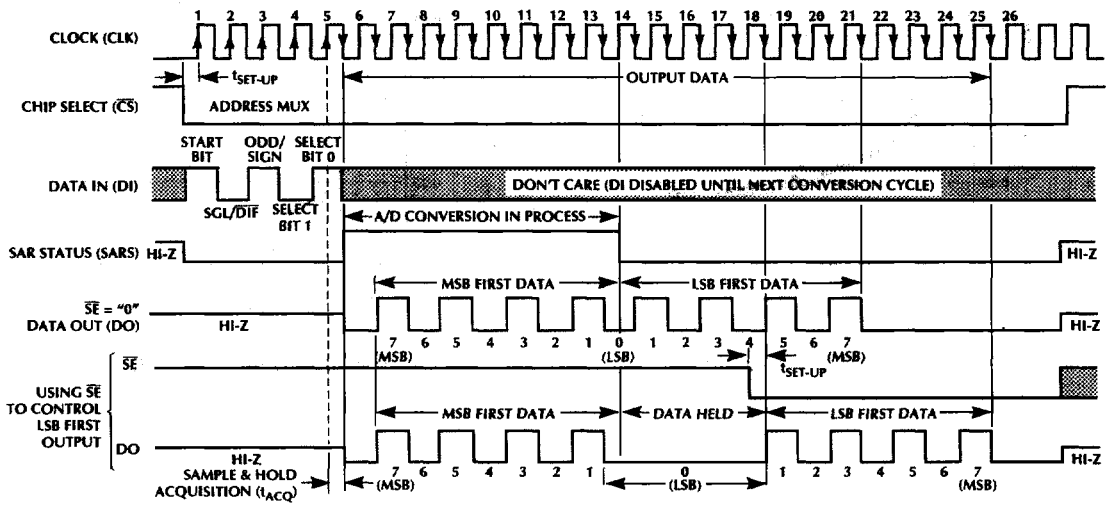

Figure 2. Timing Diagrams (Continued)

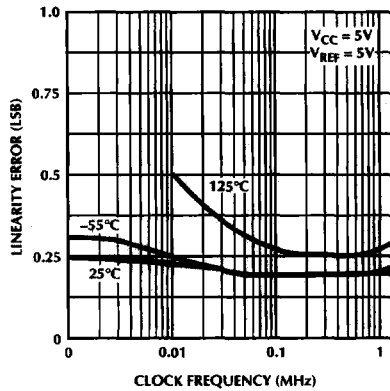

Figure 3. Linearity Error vs f_{CLK}

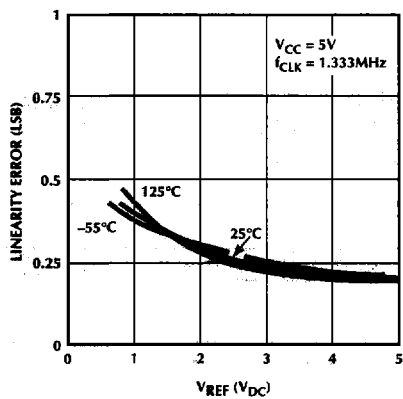

Figure 4. Linearity Error vs V_{REF} Voltage

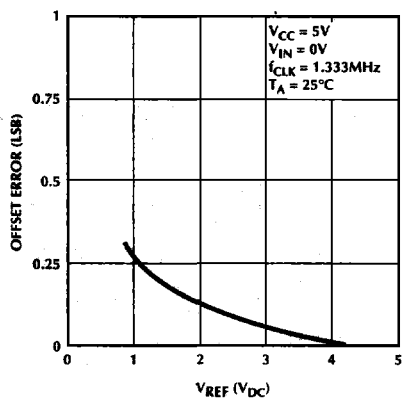
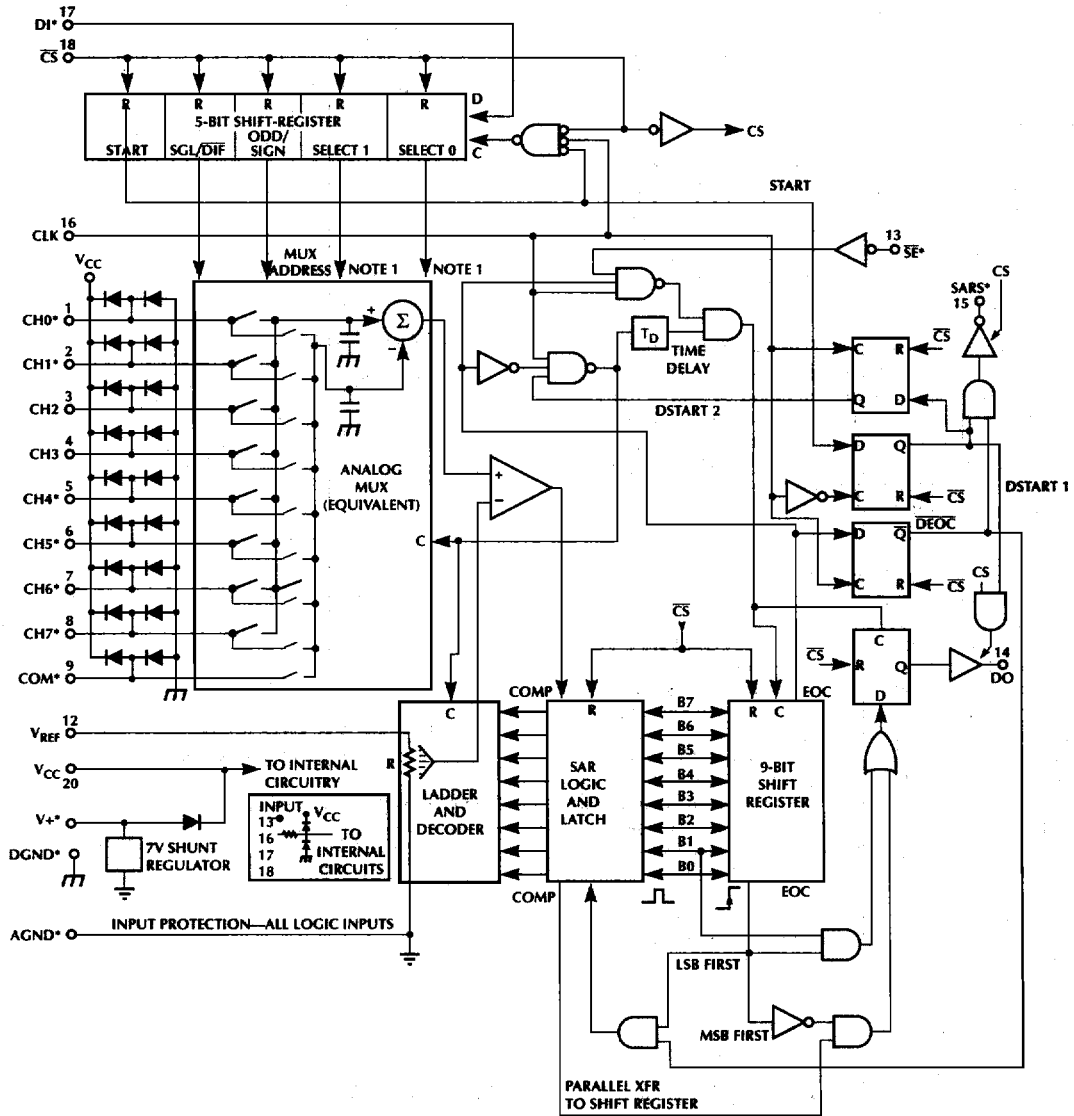

Figure 5. Unadjusted Offset Error vs V_{REF} Voltage



*SOME OF THESE FUNCTIONS/PINS ARE NOT AVAILABLE WITH OTHER OPTIONS.

NOTE 1: FOR THE ML2284 DI IS INPUT DIRECTLY TO THE D INPUT OF SELECT 1. SELECT 0 IS FORCED TO A "1". FOR THE ML2282, DI IS INPUT DIRECTLY TO THE D INPUT OF ODD/SIGN. SELECT 0 IS FORCED TO A "1" AND SELECT 1 IS FORCED TO A "0".

Figure 6. ML2288 Functional Block Diagram

ML2281, ML2282, ML2284, ML2288

FUNCTIONAL DESCRIPTION

MULTIPLEXER ADDRESSING

The design of these converters utilizes a sample data comparator structure which provides for a differential analog input to be converted by a successive approximation routine.

The actual voltage converted is always the difference between an assigned "+" input terminal and a "-" input terminal. The polarity of each input terminal of the pair being converted indicates which line the converter expects to be the most positive. If the assigned "+" input is less than the "-" input, the converter responds with an all zeros output code.

A unique input multiplexing scheme has been utilized to provide multiple analog channels with software configurable single ended, differential, or pseudo differential options. The pseudo differential option will convert the difference between the voltage at any analog input and a common terminal. One converter package can now accommodate ground referenced inputs and true differential inputs as well as signals with some arbitrary reference voltage.

A particular input configuration is assigned during the MUX addressing sequence, prior to the start of a conversion. The MUX address selects which of the analog inputs are to be enabled and whether this input is single ended or differential. In the differential case, it also assigns the polarity of the analog channels. Differential inputs are restricted to adjacent channel pairs. For example, channel 0 and channel 1 may be selected as a different pair but channel 0 or channel 1 cannot act differentially with any other channel. In addition to selecting the differential mode, the sign may also be selected. Channel 0 may be selected as the positive input and channel 1 as the negative input or vice versa. This programmability is illustrated by the MUX addressing codes shown in Tables 1, 2, and 3.

The MUX address is shifted into the converter via the DI input. Since the ML2281 contains only one differential input channel with a fixed polarity assignment, it does not require addressing.

The common input line on the ML2288 can be used as a pseudo differential input. In this mode, the voltage on the COM pin is treated as the "-" input for any of the other input channels. This voltage does not have to be analog ground; it can be any reference potential which is common to all of the inputs. This feature is most useful in single supply applications where the analog circuitry may be biased at a potential other than ground and the output signals are all referred to this potential.

Since the input configuration is under software control, it can be modified, as required, at each conversion. A channel can be treated as a single-ended, ground referenced input for one conversion; then it can be reconfigured as part of a differential channel for another conversion. Figure 7 illustrates these different input modes.

SINGLE-ENDED MUX MODE

MUX ADDRESS			ANALOG SINGLE-ENDED CHANNEL#									
SGL/ DIF	ODD/ SIGN	SELECT	0	1	2	3	4	5	6	7	COM	
		1										0
1	0	0	0	+								-
1	0	0	1		+							-
1	0	1	0				+					-
1	0	1	1						+			-
1	1	0	0		+							-
1	1	0	1			+						-
1	1	1	0					+				-
1	1	1	1							+		-

DIFFERENTIAL MUX MODE

MUX ADDRESS			ANALOG DIFFERENTIAL CHANNEL-PAIR#									
SGL/ DIF	ODD/ SIGN	SELECT	0		1		2		3			
		1	0	0	1	2	3	4	5	6	7	
0	0	0	0	+	-							
0	0	0	1			+	-					
0	0	1	0					+	-			
0	0	1	1								+	-
0	1	0	0	-	+							
0	1	0	1			-	+					
0	1	1	0					-	+			
0	1	1	1								-	+

Table 1. ML2288 MUX Addressing 8 Single-Ended or 4 Differential Channels

SINGLE-ENDED MUX MODE

MUX ADDRESS			CHANNEL#			
SGL/ DIF	ODD/ SIGN	SELECT	0	1	2	3
		1				
1	0	0	+			
1	0	1			+	
1	1	0		+		
1	1	1				+

COM is internally tied to AGND

DIFFERENTIAL MUX MODE

MUX ADDRESS			CHANNEL#			
SGL/ DIF	ODD/ SIGN	SELECT	0	1	2	3
		1				
0	0	0	+	-		
0	0	1			+	-
0	1	0	-	+		
0	1	1			-	+

Table 2. ML2284 MUX Addressing 4 Single-Ended or 2 Differential Channel

ML2281, ML2282, ML2284, ML2288

SINGLE-ENDED MUX MODE

MUX ADDRESS		CHANNEL#	
SGL/DIF	ODD/SIGN	0	1
1	0	+	
1	1		+

DIFFERENTIAL MUX MODE

MUX ADDRESS		CHANNEL#	
SGL/DIF	ODD/SIGN	0	1
0	0	+	-
0	1	-	+

Table 3. ML2282 MUX Addressing 2 Single-Ended or 1 Differential Channel

DIGITAL INTERFACE

The block diagram and timing diagrams in Figures 2-5 illustrate how a conversion sequence is performed.

A conversion is initiated when \overline{CS} is pulsed low. This line must be held low for the entire conversion. The converter is now waiting for a start bit and its MUX assignment word.

A clock is applied to the CLK input. On each rising edge of the clock, the data on DI is clocked into the MUX address shift register. The start bit is the first logic "1" that appears on the DI input (all leading edge zeros are ignored). After the start bit, the device clocks in the next 2 to 4 bits for the MUX assignment word.

When the start bit has been shifted into the start location of the MUX register, the input channel has been assigned and a conversion is about to begin. An interval of 1/2 clock period is used for sample & hold settling through the selected MUX channels. The SAR status output goes high at this time to signal that a conversion is now in progress and the DI input is ignored.

The DO output comes out of High impedance and provides a leading zero for this one clock period.

When the conversion begins, the output of the comparator, which indicates whether the analog input is greater than or less than each successive voltage from the internal DAC, appears at the DO output on each falling edge of the clock. This data is the result of the conversion being shifted out (with MSB coming first) and can be read by external logic or μP immediately.

After 8 clock periods, the conversion is completed. The SAR status line returns low to indicate this 1/2 clock cycle later.

The serial data is always shifted out MSB first during the conversion. After the conversion has been completed, the data can be shifted out a second time with LSB first, depending on level of \overline{SE} input. For the case of ML2288, if $\overline{SE} = 1$, the data is shifted out MSB first during the conversion only. If \overline{SE} is brought low before the end of conversion (which is signalled by the high to low transition of SARS), the data is shifted out again immediately after the end of conversion; this time LSB first. If \overline{SE} is brought low after end of conversion, the LSB first data is shifted out on falling edges of clock after \overline{SE} goes low. For ML2282 and 2284, \overline{SE} is internally tied low, so data is shifted out MSB first, then shifted out a second time LSB first at end of conversion. For ML2281, \overline{SE} is internally tied high, so data is shifted out only once MSB first.

All internal registers are cleared when the \overline{CS} input is high. If another conversion is desired, \overline{CS} must make a high to low transition followed by address information.

The DI input and DO output can be tied together and controlled through a bidirectional μP I/O bit with one connection. This is possible because the DI input is only latched in during the MUX addressing interval while the DO output is still in the high impedance state.

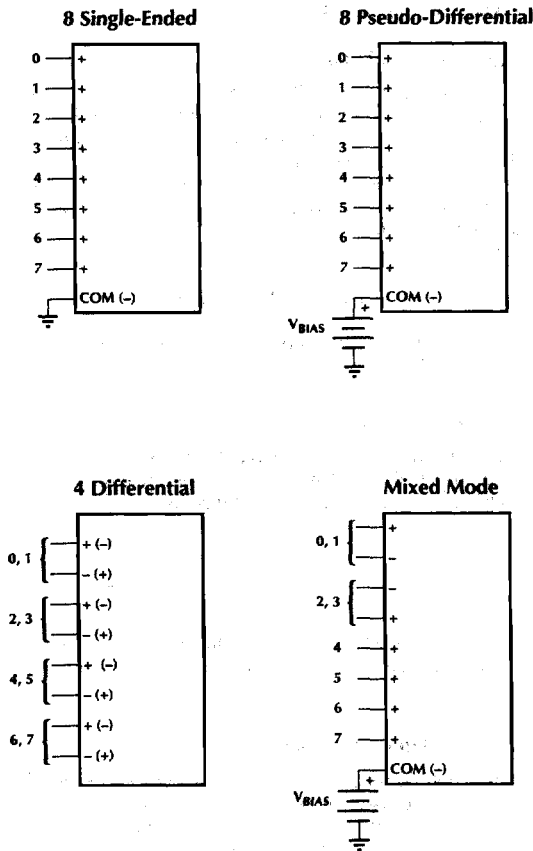

Figure 7. Analog Input Multiplexer Functional Options for ML2288

REFERENCE

The voltage applied to the reference input to these converters defines the voltage span of the analog input (the difference between $V_{IN\ MAX}$ and $V_{IN\ MIN}$) over which the 256 possible output codes apply. The devices can be used in either ratiometric applications or in systems requiring absolute accuracy. The reference pin must be connected to a voltage source capable of driving the reference input resistance, typically 10k. This pin is the top of a resistor divider string used for the successive approximation conversion.

In a ratiometric system, the analog input voltage is proportional to the voltage used for the A/D reference. This voltage is typically the system power supply, so the V_{REF} pin can be tied to V_{CC} . This technique relaxes the stability requirements of the system reference as the analog input and A/D reference move together maintaining the same output code for a given input condition.

For absolute accuracy, where the analog input varies between specific voltage limits, the reference pin can be biased with a time and temperature stable voltage source.

The maximum value of the reference is limited to the V_{CC} supply voltage. The minimum value, however, can be quite small to allow direct conversion of inputs with less than 5V of voltage span. Particular care must be taken with regard to noise pickup, circuit layout and system error voltage sources when operating with a reduced span due to the increased sensitivity of the converter.

ANALOG INPUTS AND SAMPLE/HOLD

An important feature of the ML2281 family of devices is that they can be located at the source of the analog signal and then communicate with a controlling μP with just a few wires. This avoids bussing the analog inputs long distances and thus reduces noise pickup on these analog lines. However, in some cases, the analog inputs have a large common mode voltage or even some noise present along with the valid analog signal.

The differential input of these converters reduces the effects of common mode input noise. Thus, if a common mode voltage is present on both "+" and "-" inputs, such as 60Hz, the converter will reject this common mode voltage since it only converts the difference between "+" and "-" inputs.

The ML2281 family have a true sample and hold circuit which samples both "+" and "-" inputs simultaneously. This simultaneous sampling with a true S/H will give common mode rejection and AC linearity performance that is superior to devices where the two input terminals are not sampled at the same instant and where true sample and hold capability does not exist. Thus, the ML2281 family of devices can reject AC common mode signals from DC-50kHz as well as maintain linearity for signals from DC-50kHz.

The signal at the analog input is sampled during the interval when the sampling switch is closed prior to conversion start. The sampling window (S/H acquisition time) is 1/2 CLK period wide and occurs 1/2 CLK period before DO goes from high impedance to active low state. When the sampling switch closes at the start of the S/H acquisition time, 8pF of capacitance is thrown onto the analog input. 1/2 CLK period later, the sampling switch is opened and the signal present at the analog input is stored. Any error on the analog input at the end of the S/H acquisition time will cause additional conversion error. Care should be taken to allow adequate charging or settling time from the source. If more charging or settling time is needed to reduce these analog input errors, a longer CLK period can be used.

The ML2281X family has improved latchup immunity. Each analog input has dual diodes to the supply rails, and a minimum of $\pm 25mA$ ($\pm 100mA$ typically) can be injected into each analog input without causing latchup.

DYNAMIC PERFORMANCE

Signal-to-Noise-Ratio

Signal-to-noise ratio (SNR) is the measured signal-to-noise at the output of the converter. The signal is the RMS magnitude of the fundamental. Noise is the RMS sum of all the nonfundamental signals up to half the sampling frequency. SNR is dependent on the number of quantization levels used in the digitization process; the more levels, the smaller the quantization noise. The theoretical SNR for a sine wave is given by

$$SNR = (6.02N + 1.76)dB$$

where N is the number of bits. Thus for ideal 8-bit converter, SNR = 49.92dB.

Harmonic Distortion

Harmonic distortion is the ratio of the RMS sum of harmonics to the fundamental. Total harmonic distortion (THD) of the ML2281 Series is defined as

$$THD = 20 \log \frac{\sqrt{V_2^2 + V_3^2 + V_4^2 + V_5^2}}{V_1}$$

where V_1 is the RMS amplitude of the fundamental and V_2, V_3, V_4, V_5 are the RMS amplitudes of the individual harmonics.

Intermodulation Distortion

With inputs consisting of sine waves at two frequencies, f_A and f_B , any active device with nonlinearities will create distortion products, of order $(m + n)$, at sum and difference frequencies of $mf_A + nf_B$, where $m, n = 0, 1, 2, 3, \dots$. Intermodulation terms are those for which m or n is not equal to zero. The (IMD) intermodulation distortion specification includes the second order terms $(f_A + f_B)$ and $(f_A - f_B)$ and the third order terms $(2f_A + f_B), (2f_A - f_B), (f_A + 2f_B)$ and $(f_A - 2f_B)$ only.

ZERO ERROR ADJUSTMENT

The zero of the A/D does not require adjustment. If the minimum analog input voltage value, $V_{IN\ MIN}$ is not ground, a zero offset can be done. The converter can be made to output 00000000 digital code for this minimum input voltage by biasing any V_{IN-} input at this $V_{IN\ MIN}$ value. This utilizes the differential mode operation of the A/D.

The zero error of the A/D converter relates to the location of the first riser of the transfer function and can be measured by grounding the V_{IN-} input and applying a small magnitude positive voltage to the V_{IN+} input. Zero error is the difference between the actual DC input voltage which is necessary to just cause an output digital code transition from 00000000 to 00000001 and the ideal 1/2 LSB value (1/2 LSB = 9.8mV for $V_{REF} = 5.000V_{DC}$).

FULL-SCALE ADJUSTMENT

The full-scale adjustment can be made by applying a differential input voltage which is 1-1/2 LSB down from the desired analog full-scale voltage range and then adjusting the magnitude of the V_{REF} input or V_{CC} for a digital output code which is just changing from 11111110 to 11111111.

ADJUSTMENT FOR AN ARBITRARY ANALOG INPUT VOLTAGE RANGE

If the analog zero voltage of the A/D is shifted away from ground (for example, to accommodate an analog input signal which does not go to ground), this new zero reference should be properly adjusted first. A V_{IN+} voltage which equals this desired zero reference plus 1/2 LSB

(where the LSB is calculated for the desired analog span, 1 LSB = analog span/256) is applied to selected "+" input and the zero reference voltage at the corresponding "-" input should then be adjusted to just obtain the 00000000 to 00000001 code transition.

The full-scale adjustment should be made by forcing a voltage to the V_{IN+} input which is given by:

$$V_{IN+ fs\ adjust} = V_{MAX} - 1.5 \times \left[\frac{(V_{MAX} - V_{MIN})}{256} \right]$$

where V_{MAX} = high end of the analog input range
 V_{MIN} = low end (offset zero) of the analog range
 The V_{REF} or V_{CC} voltage is then adjusted to provide a code change from 11111110 to 11111111.

SHUNT REGULATOR

A unique feature of ML2288 and ML2284 is the inclusion of a shunt regulator connected from $V+$ terminal to ground which also connects to the V_{CC} terminal (which is the actual converter supply) through a silicon diode as shown in Figure 8. When the regulator is turned on, the $V+$ voltage is clamped at $11V_{BE}$ set by the internal resistor ratio. The typical I-V of the shunt regulator is shown in Figure 9. It should be noted that before $V+$ voltage is high enough to turn on the shunt regulator (which occurs at about 5.5V), 35k Ω resistance is observed between $V+$ and GND. When the shunt regulator is not used, $V+$ pin should be either left floating or tied to GND. The temperature coefficient of the regulator is $-22mV/^{\circ}C$.

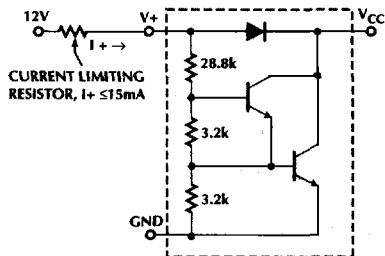

Figure 8. Shunt Regulator

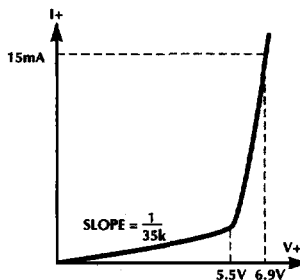
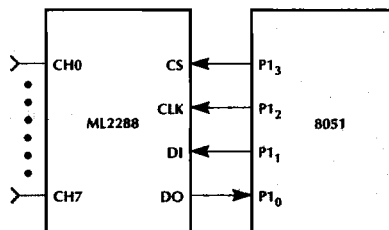

Figure 9. I-V Characteristic of the Shunt Regulator

ML2281, ML2282, ML2284, ML2288

APPLICATIONS



8051 Interface and Controlling Software

MNEMONIC		INSTRUCTION	
START	ANL MOV MOV	P1, #0F7H B, #5 A, #ADDR	;SELECT A/D (CS = 0) ;BIT COUNTER ← 5 ;A ← MUX BIT
LOOP 1:	RRC JC	A ONE	;CY ← ADDRESS BIT ;TEST BIT ;BIT = 0
ZERO:	ANL SJMP	P1, #0FEH CONT	;DI ← 0 ;CONTINUE ;BIT = 1
ONE:	ORL	P1, #1	;D1 ← 1
CONT:	ACALL DJNZ ACALL MOV	PULSE B, LOOP 1 PULSE B, #8	;PULSE SK 0 → 1 → 0 ;CONTINUE UNTIL DONE ;EXTRA CLOCK FOR SYNC ;BIT COUNTER ← 8
LOOP 2:	ACALL MOV RRC RRC MOV RLC MOV DJNZ	PULSE A, P1 A A A, C A C, A B, LOOP 2	;PULSE SK 0 → 1 → 0 ;CY ← DO ;A ← RESULT ;A(0) BIT ← AND SHIFT ;C ← RESULT ;CONTINUE UNTIL DONE
RETI			;PULSE SUBROUTINE
PULSE:	ORL NOP ANL RET	P1, #04 P1, #0FBH	;SK ← 1 ;DELAY ;SK ← 0

APPLICATIONS (Continued)

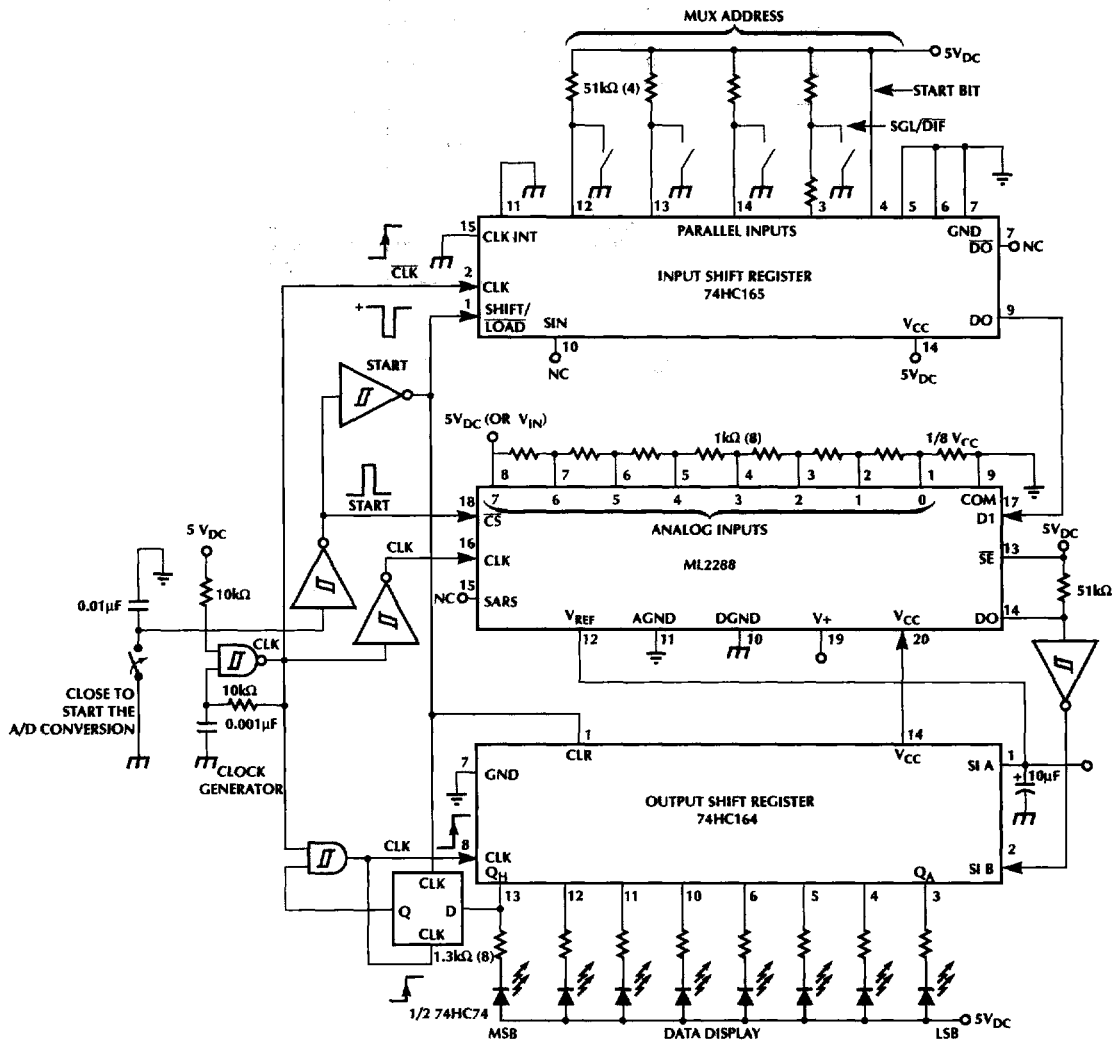

ML2288 "Stand-Alone" or Evaluation Circuit

APPLICATIONS (Continued)

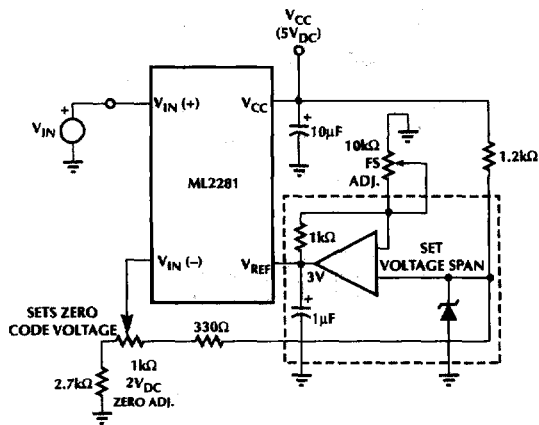

Zero-Shift and Span Adjust: $2V \leq V_{IN} \leq 5V$

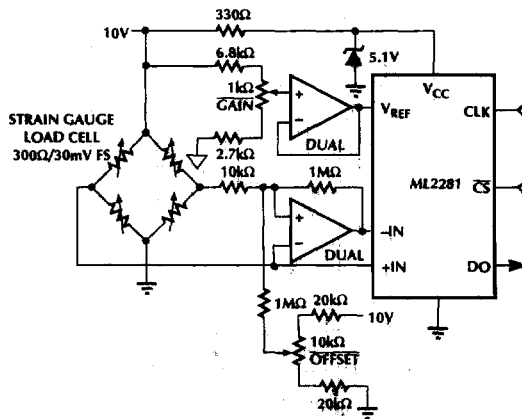

- USES ONE MORE WIRE THAN LOAD CELL ITSELF
- TWO MINI-DIPs COULD BE MOUNTED INSIDE LOAD CELL FOR DIGITAL OUTPUT TRANSDUCER
- ELECTRONIC OFFSET AND GAIN TRIMS RELAX MECHANICAL SPECS FOR GAUGE FACTOR AND OFFSET
- LOW LEVEL CELL OUTPUT IS CONVERTED IMMEDIATELY FOR HIGH NOISE IMMUNITY

Digital Load Cell

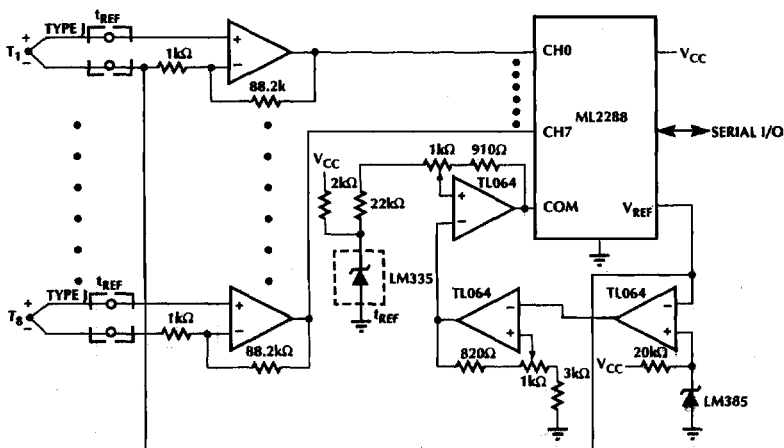

USES THE PSEUDO-DIFFERENTIAL MODE TO KEEP THE DIFFERENTIAL INPUTS CONSTANT WITH CHANGES IN REFERENCE TEMPERATURE (T_{REF})

Convert 8 Thermocouples with only One Cold-Junction Compensator

ML2281, ML2282, ML2284, ML2288

APPLICATIONS (Continued)

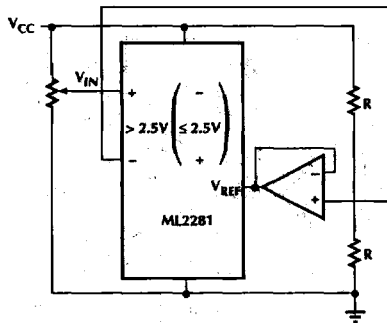

CONTROLLER PERFORMS A ROUTINE TO DETERMINE WHICH INPUT POLARITY PROVIDES A NON-ZERO OUTPUT CODE. THIS INFORMATION PROVIDES THE EXTRA BITS.

Obtaining 9-Bit Resolution

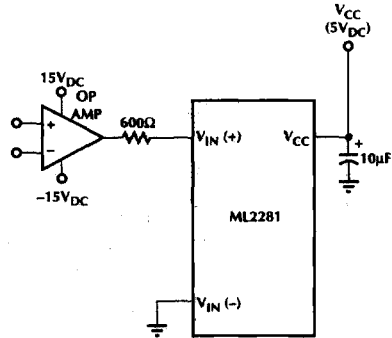

DIODE CLAMPING IS NOT NEEDED IF CURRENT IS LIMITED TO 25mA

Protecting the Input

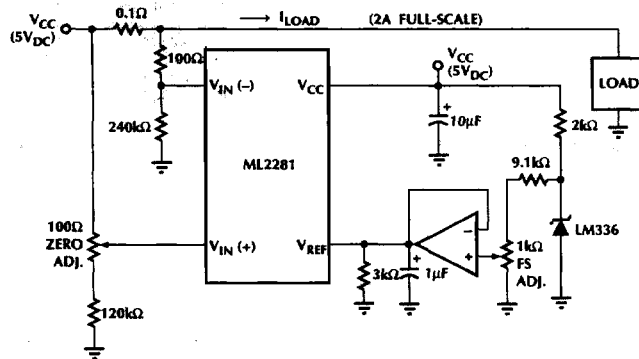

Digitizing a Current Flow

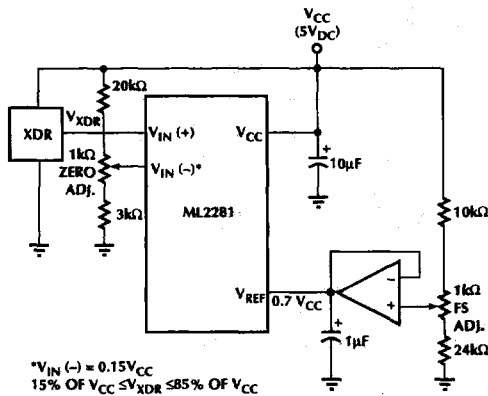

Operating with Ratiometric Transducers

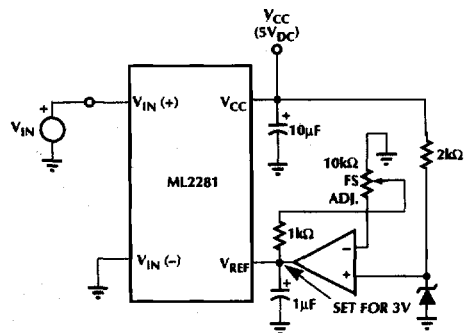

Span Adjust: $0V \leq V_{IN} \leq 3V$

APPLICATIONS (Continued)

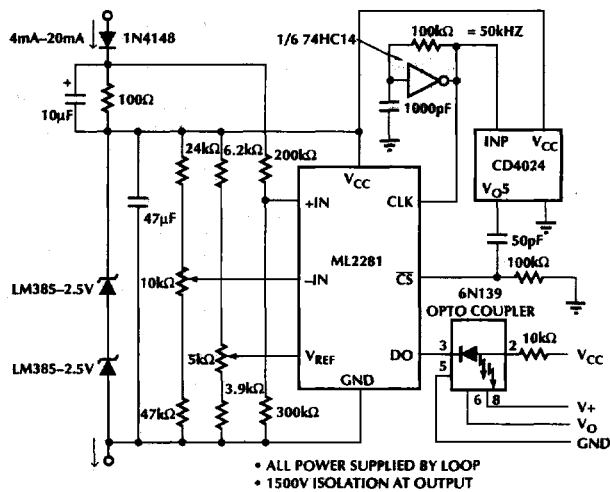

4mA-20mA Current Loop Converter

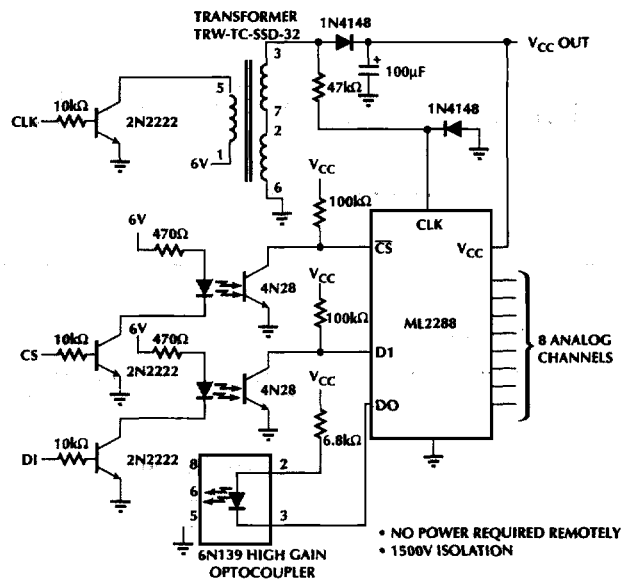

Isolated Data Converter

ML2281, ML2282, ML2284, ML2288

APPLICATIONS (Continued)

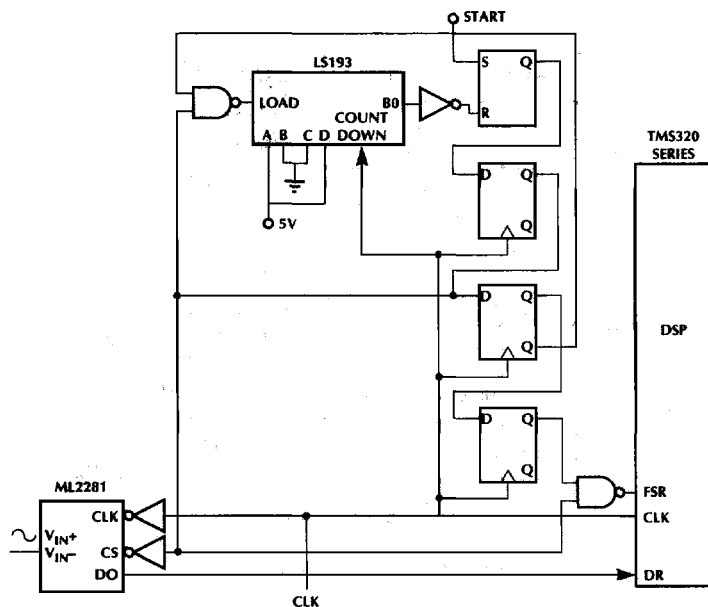

Sampling Rate 111kHz, Data Rate 1.33MHz

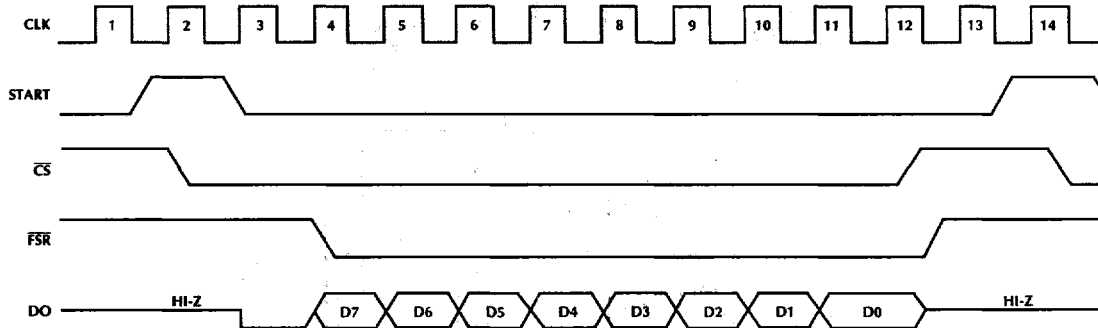

Interfacing ML2281 to TMS320 Series

ORDERING INFORMATION

PART NUMBER	ALTERNATE PART NUMBER	TOTAL UNADJUSTED ERROR	TEMPERATURE RANGE	PACKAGE
SINGLE ANALOG INPUT, 8-PIN PACKAGE				
ML2281BIP ML2281BCP ML2281BCS	ADC0831CCN ADC0831BCN —	±1/2 LSB	-40°C to 85°C 0°C to 70°C 0°C to 70°C	Plastic DIP (P08) Molded DIP (P08) Plastic SOIC (S08)
ML2281CIP ML2281CCP ML2281CCS	ADC0831BCN ADC0831CCN —	±1 LSB	-40°C to 85°C 0°C to 70°C 0°C to 70°C	Plastic DIP (P08) Molded DIP (P08) Plastic SOIC (S08)
TWO ANALOG INPUTS, 8-PIN PACKAGE				
ML2282BIP ML2282BCP ML2282BCS	ADC0832CCN ADC0832BCN —	±1/2 LSB	-40°C to 85°C 0°C to 70°C 0°C to 70°C	Plastic DIP (P08) Molded DIP (P08) Plastic SOIC (S08)
ML2282CIP ML2282CCP ML2282CCS	ADC0832BCN ADC0832CCN —	±1 LSB	-40°C to 85°C 0°C to 70°C 0°C to 70°C	Plastic DIP (P08) Molded DIP (P08) Plastic SOIC (S08)
FOUR ANALOG INPUTS, 14-PIN PACKAGE				
ML2284BIP ML2284BCP ML2284BCS	ADC0834CCN ADC0834BCN —	±1/2 LSB	-40°C to 85°C 0°C to 70°C 0°C to 70°C	Plastic DIP (P14) Molded DIP (P14) Plastic SOIC (S14)
ML2284CIP ML2284CCP ML2284CCS	ADC0834BCN ADC0834CCN —	±1 LSB	-40°C to 85°C 0°C to 70°C 0°C to 70°C	Plastic DIP (P14) Molded DIP (P14) Plastic SOIC (S14)
EIGHT ANALOG INPUTS, 20-PIN PACKAGE				
ML2288BIP ML2288BCP ML2288BCQ	ADC0838CCN ADC0838BCN ADC0838BCV	±1/2 LSB	-40°C to 85°C 0°C to 70°C 0°C to 70°C	Plastic DIP (P20) Molded DIP (P20) Molded PCC (Q20)
ML2288CIP ML2288CCP ML2288CCQ	ADC0838CCN ADC0838CCN ADC0838CCV	±1 LSB	-40°C to 85°C 0°C to 70°C 0°C to 70°C	Plastic DIP (P20) Molded DIP (P20) Molded PCC (Q20)