

PRODUCT DATA SHEET
SFP TRANSCEIVER
for SONET/SDH

HTR6713 Series
for OC-3 IR-1 (up to 15km)



Features

- SONET OC-3 IR-1 (155.52Mbit/s, 15km) and SDH STM-1(S-1.1) compliant. (Also compatible to the data rate of 125Mbit/s for Fast Ethernet)
- Fully comply with industry standard Small Form Factor Pluggable transceiver (Hot pluggable).
- AEL class 1 laser product per FDA/CDRH and EN60825-1 laser safety regulations.
- LC duplex receptacle.
- Metal cover and inner shield for low EMI emission.
- SFP MSA compliant delatch mechanism and improved handling type (single or double bail type) delatch mechanism and improved ESD immunity type bail are available. ESD improved type has plastic under cover and hook to boost the ESD immunity when electrostatic discharge is applied to the bail.
- +3.3V single power supply.
- Low power consumption (0.4W(typ.)).

1. General

This document specifies the characteristics of the Small Form Factor Pluggable optical transceiver (Type:HTR6713) with LC duplex receptacle for an OC-3 Intermediate Reach interface (IR-1, up to 15km). This transceiver apply single mode optical fiber - 9/125.

2. Function

This transceiver is powered from a single +3.3V power supply and operated at a data rate of 155.52Mbit/s and 125Mbit/s(duty 50%). Optical output power is held constant by automatic power control over the specified operating temperature and voltage ranges.

The optical output is disabled by a TTL logic level input for that purpose. Tx Fault is provided to indicate the degradation of the laser diode. Loss Of Signal (LOS) output is provided to indicate the loss of an incoming optical signal. Tx Fault and LOS are open collector type outputs. The type of this transceiver is identified by Module Definition function using a built-in EEPROM with I²C interface.

Dimensions and pin assignment fully comply with MSA (Multi Source Agreement) for SFP (Small Form Factor Pluggable) type optical transceiver.

3. Explanation of Part Number

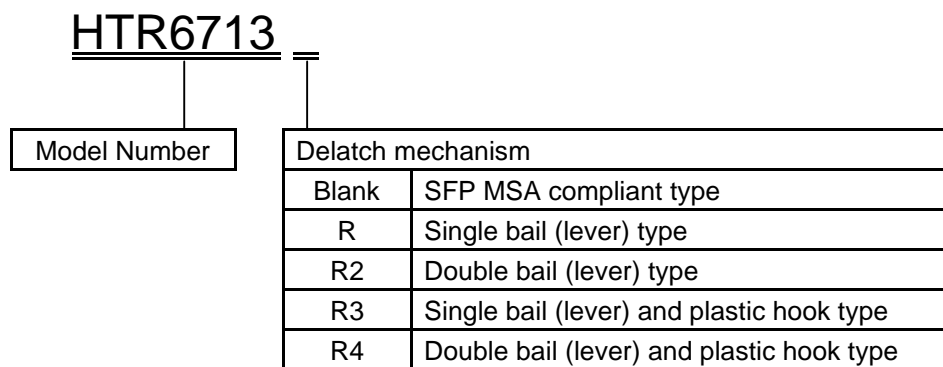

4. Absolute Maximum Ratings

Stresses in excess of the ratings listed in Table 1 can cause permanent damage to the device and affect device reliability. Functional operation of the device is not implied at any condition in excess of those given in the operating specification.

Table 1. Absolute Maximum Ratings

Parameter	Symbol	Min.	Max.	Unit
Supply Voltage	V_{CC}	0	4.0	V
Data Input Voltage	V_{IN}	V_{EE}	$V_{CC}+0.3$	V
Receiver Optical Input Power	P_{in}	-	+3	dBm
Operating Ambient Temperature	T_A	-5	70	deg-C
Storage Case Temperature	T_{stg}	-40	85	deg-C
Operating Relative Humidity (non-condensing)	H_A	5	85	%

5. Optical and Electrical Characteristics of Transmitter Portion

Optical and electrical characteristics of transmitter portion are shown in Table 2. Unless otherwise stated, minimum and maximum values are specified over the operating ambient temperature, and humidity ranges, DC power supply voltage range, from beginning to end of life, using 2²³-1 pseudo random bit stream with a 50% duty factor.

The logic sense for the DATA input is such that a logic “1”(High) corresponds to the maximum level of an amplitude modulated light source (Light on), while a logic “0”(Low) corresponds to a minimum level of an amplitude modulated light source (Light off).

Table 2. Transmitter Optical and Electrical Characteristics

Parameter	Symbol	Min	Typ	Max	Unit
Optical Output Power	P _o	-15	-	-8	dBm
Center Wavelength	λ	1261	-	1360	nm
Spectral Width(RMS)	$\Delta\lambda$	-	-	7.7	nm
SONET Eye Mask	-	Compliant with GR253 spec.			-
Extinction Ratio	-	8.2	-	-	dB
DC Power Supply Voltage	V _{cc}	3.135	3.3	3.465	V
DC Power Supply Current	I _{cc}	-	-	100	mA
Data Input Voltage ^a					
Diff'l Input Swing	V _{ID SWING}	500	-	2400	mV _{p-p}
Diff'l Input Impedance	Z _{ID}	85	100	115	Ω
TX Fault Output Voltage: ^b					
Low	V _{OL}	0	-	0.8	V
High	V _{OH}	2.0	-	V _{cc}	V
Tx Disable Voltage	V _D	V _{cc} -1.3	-	V _{cc}	V
Tx Enable Voltage	V _{EN}	V _{EE}	-	V _{EE} +0.8	V

- a. AC coupled and terminated by 100ohm resistor (differentially) inside the module.
- b. Open collector output. It should be pulled up by 4.7k to 10k ohm resistor to V_{cc}.

6. Optical and Electrical Characteristics of Receiver Portion

Optical and electrical characteristics of receiver portion are shown in Table 3. Unless otherwise stated, minimum and maximum values are specified over the operating ambient temperature, and humidity ranges, DC power supply voltage range and wavelength range, from beginning to end of life, using a 2^{23} -1 pseudo random bit stream with a 50% duty factor.

Table 3. Receiver Optical and Electrical Characteristics

Parameter	Symbol	Min	Typ	Max	Unit
Optical input Power (Average) ^a	P _{IN}	-32	-	-7	dBm
Optic Path Penalty	P _O	-	-	1	dB
LOS Threshold:					
Decreasing Light Input	LOST _D	-48	-	-	dBm
Increasing Light Input	LOST _I	-43	-	-32	dBm
Hysteresis	LOST _H	0.5	-	5	dB
DC Power Supply Voltage	V _{CC}	3.135	-	3.465	V
DC Power Supply Current	I _{CC}	-	-	100	mA
Data Output Voltage ^b					
Diff'l Output Swing	V _{OD SWING}	1100	1600	2000	mV _{p-p}
Output Transition Time ^c	t _o	-	-	2.0	ns
LOS Output Voltage: ^d					
Low	V _{OL}	-	-	V _{ee} +0.4	V
High	V _{OH}	V _{CC} -0.9	-	-	V
LOS Response Time:					
Decreasing Light Input	LOSRT _D	-	-	300	μs
Increasing Light Input	LOSRT _I	-	-	100	μs

a. At a BER of 1×10^{-10} and an extinction ratio of 8.2dB

b. AC coupled inside the module

c. Between 20% and 80% (50% duty cycle)

d. Open collector output. It should be pulled up by 4.7k to 10k ohm resistor to V_{CC}.

7. Physical Design

The package outline of SFP MSA compliant delatch mechanism is shown in Figure 1.

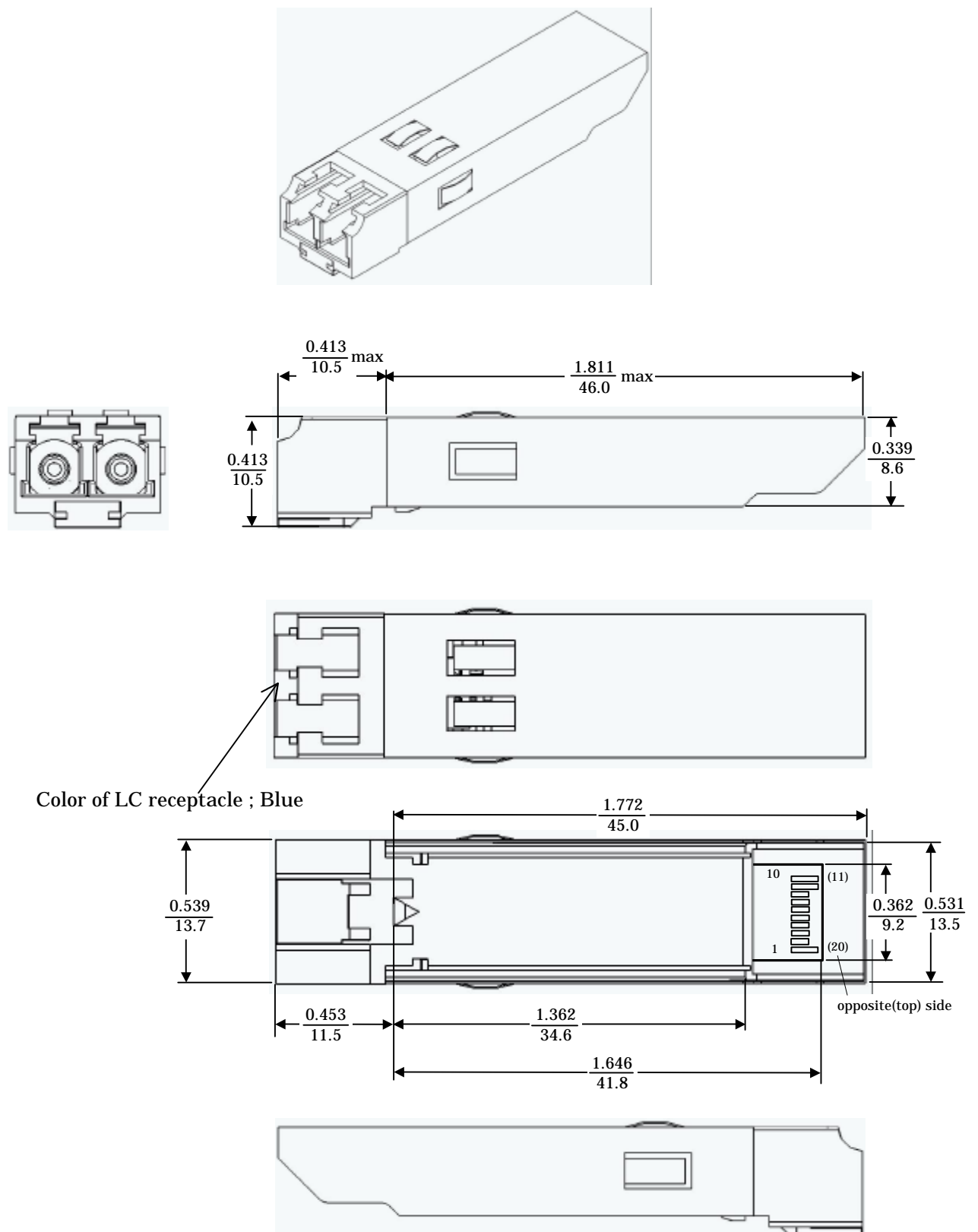

Unless otherwise stated, typical values are shown

unit: $\frac{\text{inch}}{\text{mm}}$

Figure 1. The package outline of SFP MSA compliant delatch mechanism

The package outline of bail (lever) delach mechanism type is shown in Figure 2.

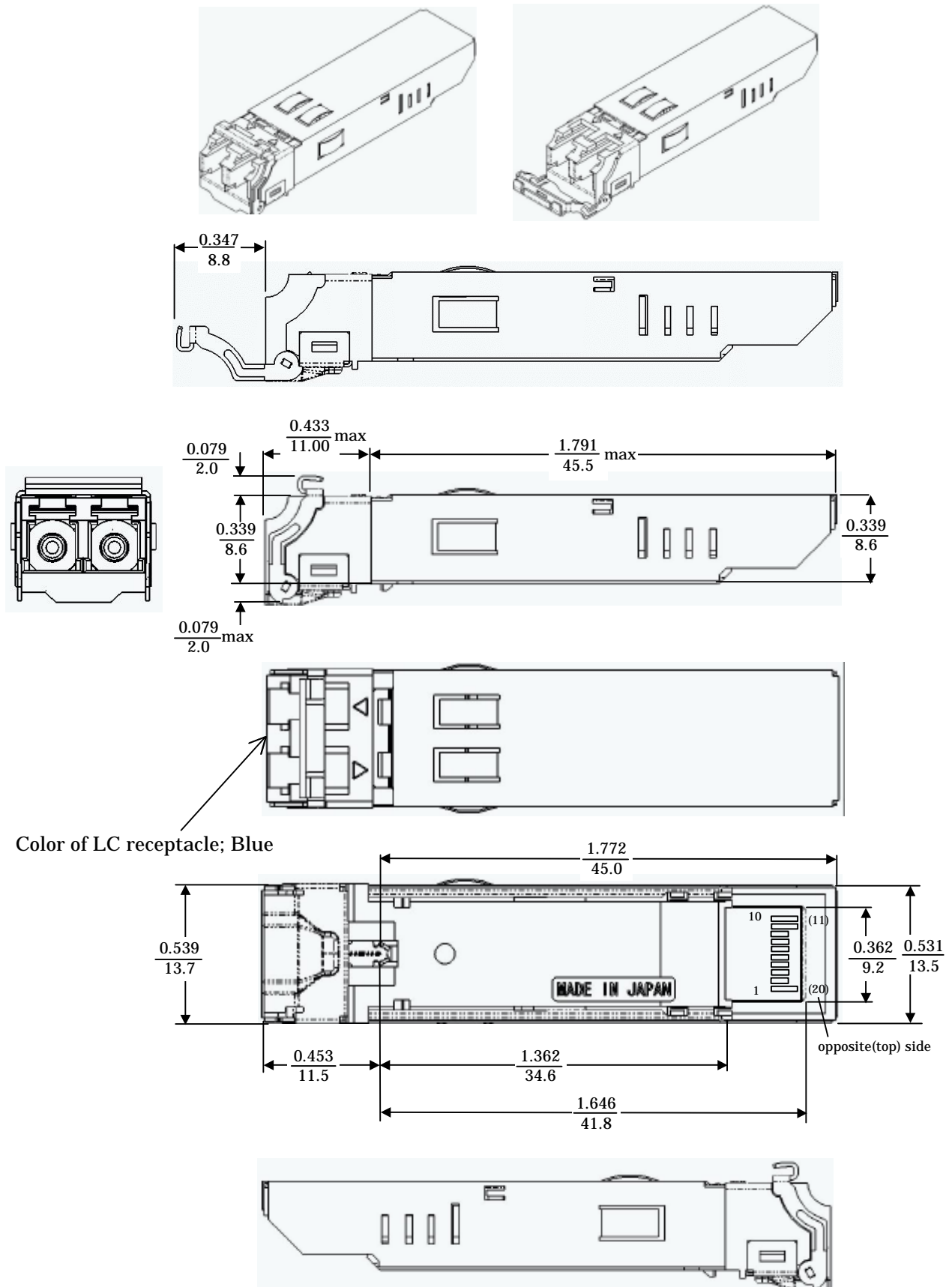

Unless otherwise stated, typical values are shown

Figure 2. The package outline of bail (lever) delach mechanism type

The package outline of double bail delach mechanism type is shown in Figure 3.

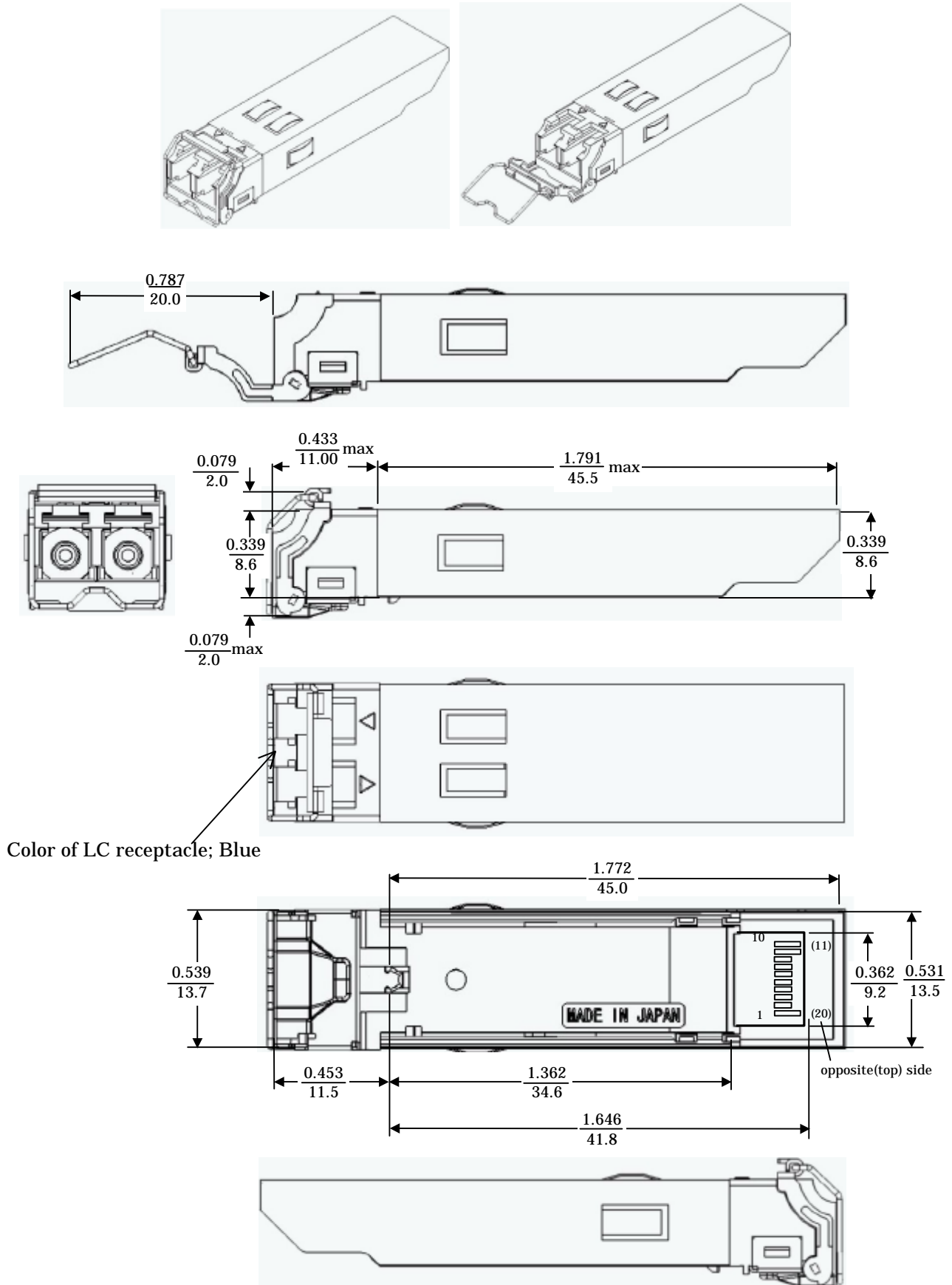

Unless otherwise stated, typical values are shown

unit: $\frac{\text{inch}}{\text{mm}}$

Figure 3. The package outline of double bail delach mechanism type

The package outline of ESD improved bail (lever) delatch mechanism type is shown in Figure 4.

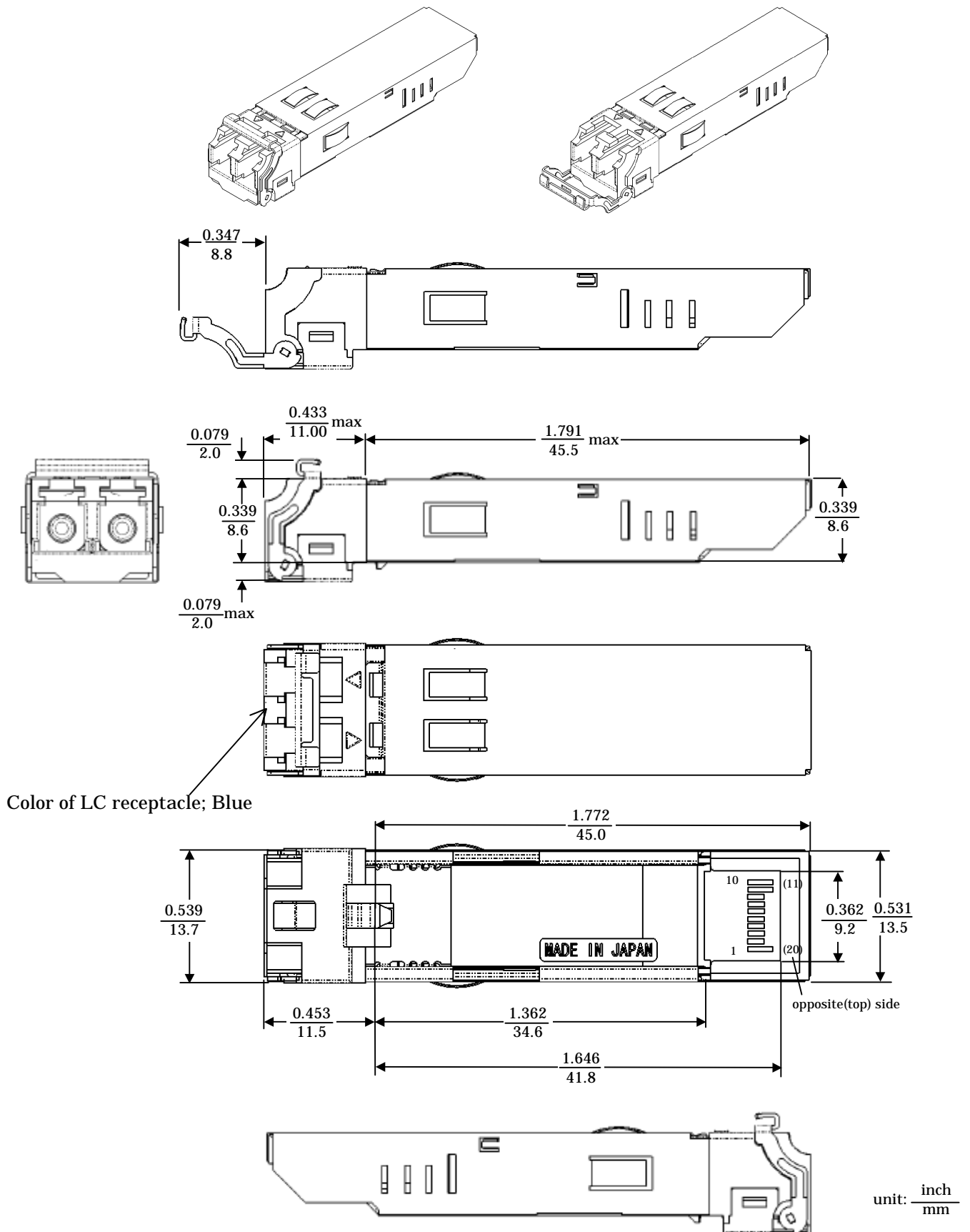

Unless otherwise stated, typical values are shown

Figure 4. The package outline of ESD improved bail (lever) delatch mechanism type

The package outline of ESD improved double bail delatch mechanism type is shown in Figure 5.

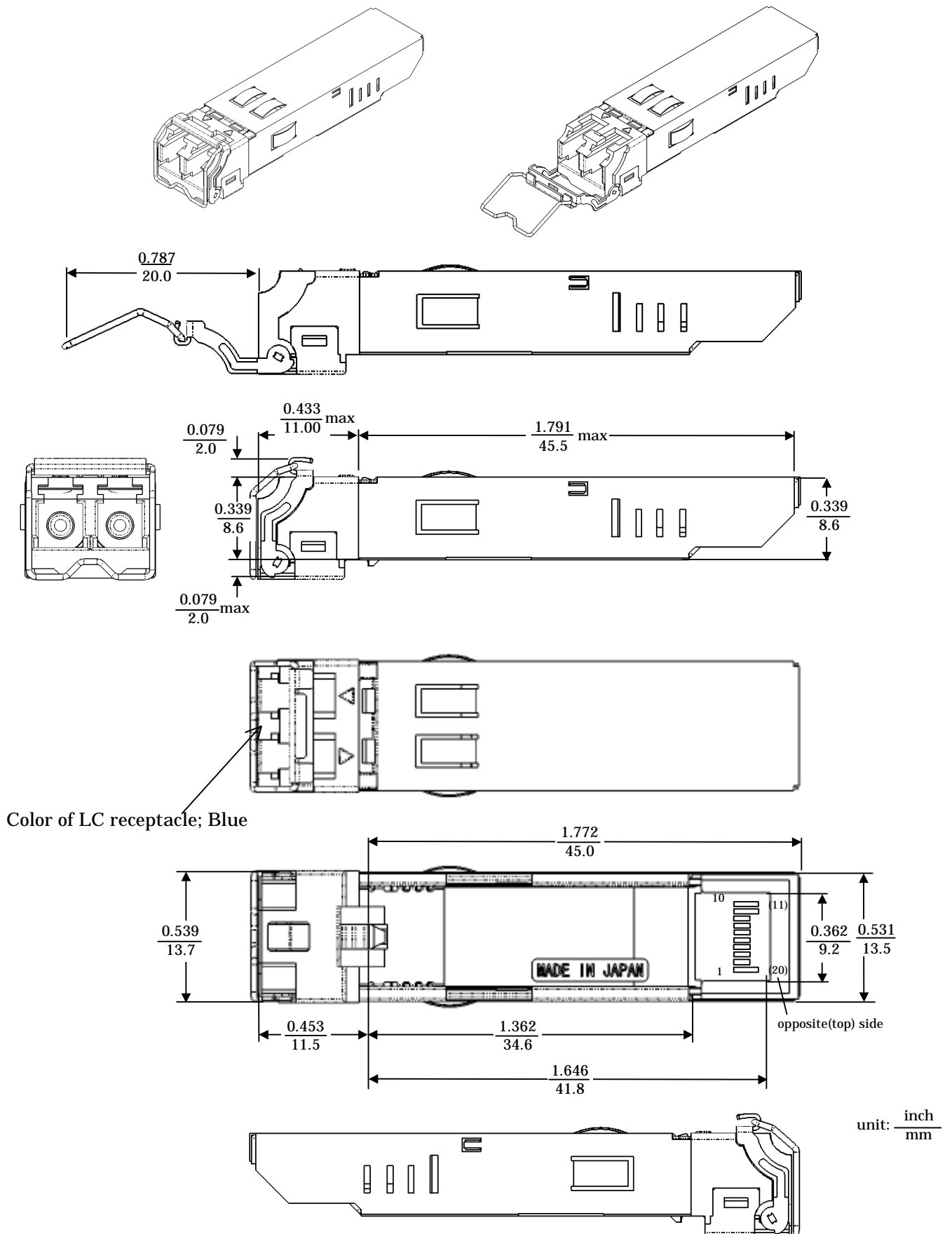

Unless otherwise stated, typical values are shown

Figure 5. The package outline of ESD improved double bail delatch mechanism type

8. Label

Label that describe the following items is indicated on the top of transceiver.

Product name, Serial number, Wavelength, Manufacture name and “CLASS 1 LASER PRODUCT”.

9. PINOUT

Pinout is shown in Table 4.

Table 4. Pin Designations

Name	Symbol	Pin		Pin	Symbol	Name
Transmitter Ground	VeeT	20		1	VeeT	Transmitter Ground
Inv. Transmit Data In	TD-	19		2	Tx Fault	Transmitter Fault Indication
Transmit Data In	TD+	18		3	Tx Disable	Transmitter Disable
Transmitter Ground	VeeT	17		4	MOD_DEF(2)*	Module Definition 2
Transmitter Power	VccT	16		5	MOD_DEF(1)*	Module Definition 1
Receiver Power	VccR	15		6	MOD_DEF(0)*	Module Definition 0
Receiver Ground	VeeR	14		7	(Rate Select)	Unused function
Received Data Out	RD+	13		8	LOS	Loss of Signal
Inv. Received Data Out	RD-	12		9	VeeR	Receiver Ground
Received Ground	VeeR	11		10	VeeR	Receiver Ground

* Mod-Def 0,1,2 are the module definition pins. They should be pulled up with a 4.7K-10KΩ resistor on the host board.

Mod-Def 0 is grounded by the module to indicate that the module is present.

Mod-Def 1 is the clock line of two wire serial interface (I²C) for serial ID.

Mod-Def 2 is the data line of two wire serial interface (I²C) for serial ID.

For use of two wire serial interface (I²C), referring to Philips I²C bus specification or ATMEL AT24C01A/02/04 data sheet is recommended. Refer to URL below for more detail:

<http://www.semiconductors.philips.com/buses/i2c/facts/index.html> or,

<http://www.atmel.com/acrobat/doc0180.pdf>

10. Block Diagram and Recommended Circuit

Block diagram and recommended decoupling and termination for HTR6713 is illustrated in Figure 6. This recommendation will provide a good performance of the optical transceiver.

Host board layout, the design of SFP cage and SFP electrical connector should comply with the SFP MSA requirements.

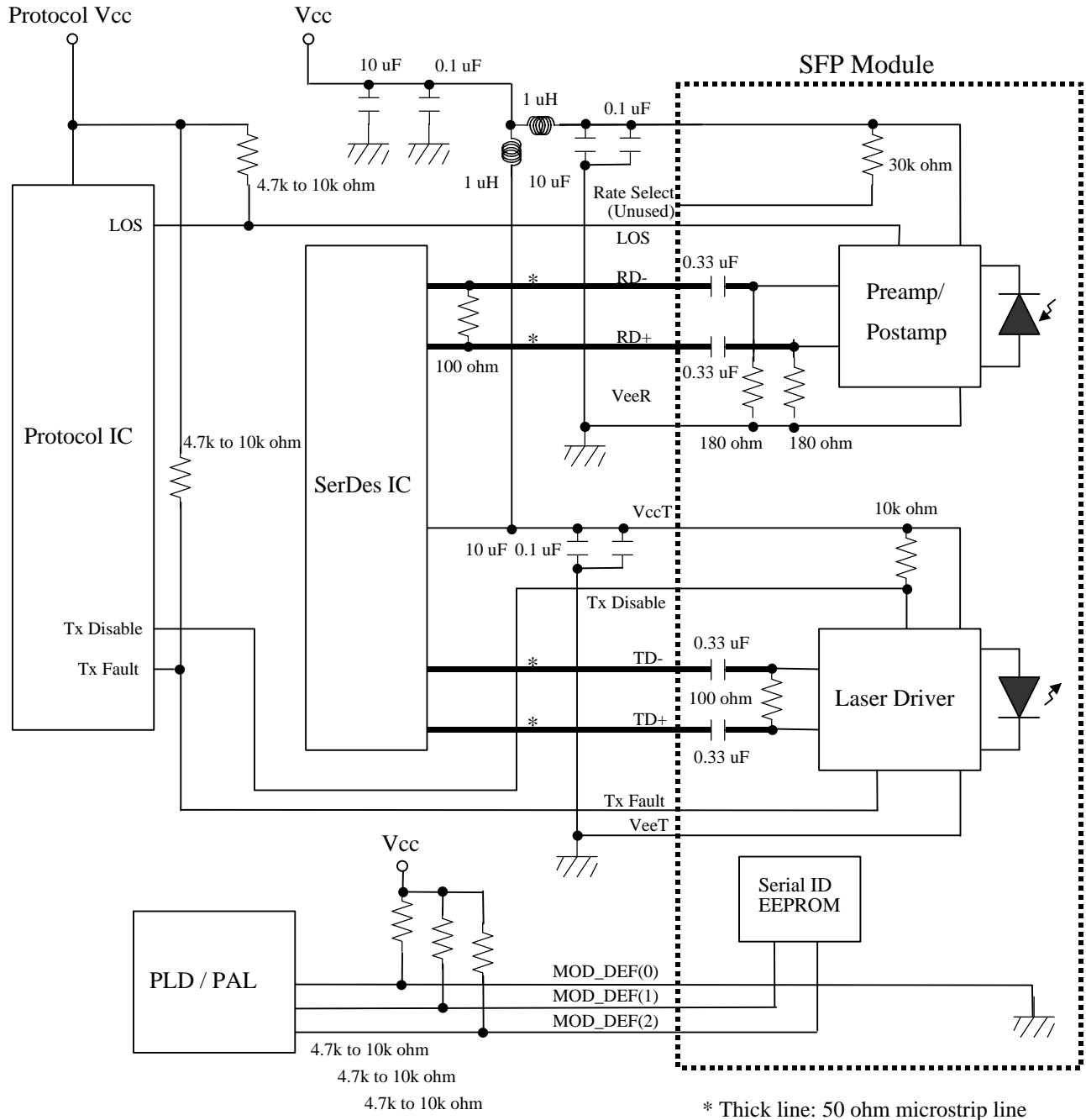

Figure 6. Block Diagram and Recommended Circuit

11. Serial identification

This transceiver features an EEPROM for Serial ID. Contents of the Serial ID are shown in Table 5.

Table 5. EEPROM Serial ID Memory Contents

Data Address	Field Size (Bytes)	Name of Field	Value(Hex)	Remark
BASE ID FIELDS				
0	1	Identifier	03	SFP
1	1	Ext.Identifier	04	
2	1	Connector	07	LC connector
3-10	8	Transceiver	00 00 02 00 00 00 00 00	Transceiver codes
11	1	Encoding	03	NRZ
12	1	BR, Nominal	02	155Mbits/sec(units of 100Mbits/sec)
13	1	Reserved	00	
14	1	Length(9u)-km	0F	15km(units of km)
15	1	Length(9u)	96	15000m(units of 100m)
16	1	Length(50u)	00	Not supported
17	1	Length(62.5u)	00	Not supported
18	1	Length(Copper)	00	Not supported
19	1	Reserved	00	Not supported
20-35	16	Vendor name	48 69 74 61 63 68 69 20 43 61 62 6C 65 20 20 20	"Hitachi Cable"(ASCII)
36	1	Reserved	00	
37-39	3	Vendor OUI	00 40 66	
40-55	16	Vendor PN	48 54 52 36 37 31 33 20 20 20 20 20 20 20 20 20 48 54 52 36 37 31 33 52 20 20 20 20 20 20 20 20 48 54 52 36 37 31 33 52 32 20 20 20 20 20 20 20 48 54 52 36 37 31 33 52 33 20 20 20 20 20 20 20 48 54 52 36 37 31 33 52 34 20 20 20 20 20 20 20	"HTR6713"(ASCII) PN of SFP MSA compliant delatch type "HTR6713R"(ASCII) PN of single bail delatch type "HTR6713R2"(ASCII) PN of double bail delatch type "HTR6713R3"(ASCII) PN of improved ESD immunity single bail "HTR6713R4"(ASCII) PN of improved ESD immunity double bail
56-59	4	Vendor rev	20 20 20 20	(ASCII)
60-61	2	Wavelength	05 1E	1310nm(16-bit unsigned integer)
62	1	Reserved	00	
63	1	CC_BASE	Check sum(Variable)	Check code for Base ID Fields
EXTENDED ID FIELDS				
64-65	2	Options	00 1A	Loss of Signal, TX_FAULT, TX_DISABLE implemented
66	1	BR, max	0A	10(units of %)
67	1	BR, min	14	20(units of %)
68-83	16	Vendor SN	30 30 30 31 32 33 20 20 20 20 20 20 20 20 20 20 (*1)	Serial number of transceiver(ASCII) (*1 Sample of number is "000123")
84-91	8	Date code	30 34 31 31 31 39 30 30 (*2)	Manufacturing date code(ASCII) (*2 Sample of date is "04111900")
92-94	3	Reserved	00 00 00	
95	1	CC_EXT	Check sum(Variable)	Check code for Extended ID Fields
VENDOR SPECIFIC ID FIELDS				
96-127	32	Reserved	Unused	Filled by zero

12. Inspection

Main inspection items are as follows:

- (1) Appearance
- (2) Dimensions
- (3) Optical output power
- (4) Optical waveform
- (5) Optical input power
 - a) Average Sensitivity
 - b) Loss of Signal / Decreasing Light Input
 - c) Loss of Signal / Increasing Light Input
- (6) Power supply current

13. Packing

The optical transceiver shall be packed in sturdy carton box(es) when shipping.

14. Cautions

- (1) Do not stare into optical output port although this product is designed to meet the class 1 laser regulation.
- (2) The housing of the transceiver is possible to crack or dissolve against the particular chemicals. Although we recommend to use the aqueous fluid in the cleaning, the below chemicals are checked not to affect to the housing. Pay attention in the solder flux and cleaning process. We recommend checking the appropriateness of the cleaning fluid in advance.

/ methyl alcohol, ethyl alcohol, butyl alcohol, isopropyl alcohol, hexane, cyclohexane, naphtha, tetrachloroethylene, propylene glycol,

< Do not use : Chemicals which are checked to crack or dissolve>
/ trichloroethylene, trichloroethane, benzen, methyl ethyl ketone, chloroform, toluene, acetone, phenol, ethyl acetate, methylene di chloride, isophtalic acid dimethyl ester
- (3) Optical connectors should be cleaned completely by proper cleaning process before insertion to optical receptacles of the transceiver to avoid contamination inside the optical receptacle. The contamination may cause serious degradation of transmission performance. Using forced nitrogen and some kind of cleaning stick ("CLETOP, stick type" for LC/MU connector supplied by NTT international is recommended) should be used if the receptacle get contaminated by miss-treating optical connectors.

= MEMO =

= Notice =

- All information contained in this document is subject to change without notice.
- No responsibility is assumed by Hitachi Cable, Ltd. For its use nor for any infringements of third parties, which may result from its use.
- Products described in this document are not intended for use in implantation or other life support applications where malfunction may result in injury or death to persons.
- Customer must contact Hitachi Cable, Ltd. to obtain the latest specification to verify, before placing any order, that the information contained herein is current.

 **Hitachi Cable, Ltd.** <http://www.hitachi-cable.co.jp/>

Hitachi Cable America, Inc. <http://www.hitachi-cable.com/>