

Silicon Bi-directional Trigger Device

BR100/03 LLD

GENERAL DESCRIPTION

Silicon bidirectional trigger device in a glass envelope suitable for surface mounting. The device is intended for use in triac and thyristor trigger circuits.

QUICK REFERENCE DATA

SYMBOL	PARAMETER	MIN.	MAX.	UNIT
$V_{(BO)}$	Breakover voltage	28	36	V
V_O	Output voltage	7	-	V
I_{FRM}	Repetitive peak forward current	-	2	A

OUTLINE - SOD80

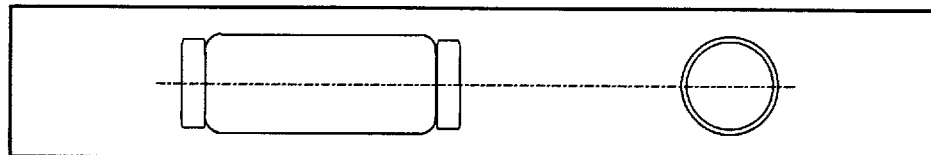

SYMBOL

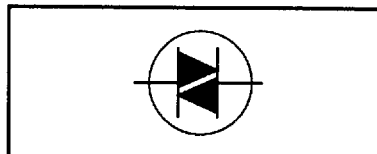

LIMITING VALUES

Limiting values in accordance with the Absolute Maximum System (IEC 134).

SYMBOL	PARAMETER	CONDITIONS	MIN.	MAX.	UNIT
I_{FRM}	Repetitive peak forward current	$t \leq 10 \mu s, T_{tp} \leq 50^\circ C; f = 60 \text{ Hz}$	-	2	A
P_{tot}	Total power dissipation	$T_{tp} = 50^\circ C$	-	150	mW
T_{stg}	Storage temperature		-55	125	$^\circ C$
T_j	Operating junction temperature		-	100	$^\circ C$

THERMAL RESISTANCES

SYMBOL	PARAMETER	CONDITIONS	MIN.	TYP.	MAX.	UNIT
$R_{th j-tp}$	Thermal resistance junction to tie point	PCB mounted	-	330	-	K/W

CHARACTERISTICS

$T_a = 25^\circ C$ unless otherwise stated.

SYMBOL	PARAMETER	CONDITIONS	MIN.	TYP.	MAX.	UNIT
$V_{(BO)}$	Breakover voltage	$I = I_{(BO)}$	28	32	36	V
$ V_{(BO)+} - V_{(BO)-} $	Breakover voltage symmetry	$I = I_{(BO)}$, see fig: 1	-	-	3.5	V
V_O	Output voltage	$R_L = 20 \Omega$; Circuit of fig: 2	7	-	-	V
$I_{(BO)}$	Breakover current	$V = V_{(BO)}$	-	-	50	μA
$dV_{(BO)}/dT$	Temperature coefficient of $V_{(BO)}$		-	0.1	-	%/K
t_r	Risetime	$I_p = 0.5 \text{ A}$; Circuit of fig: 2	-	1.5	-	μs

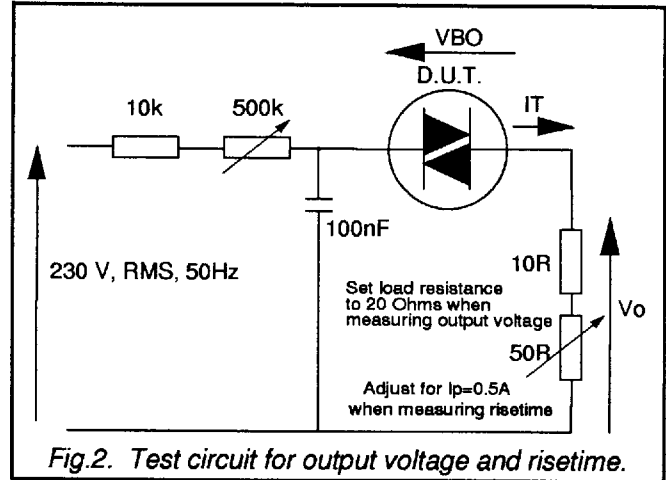
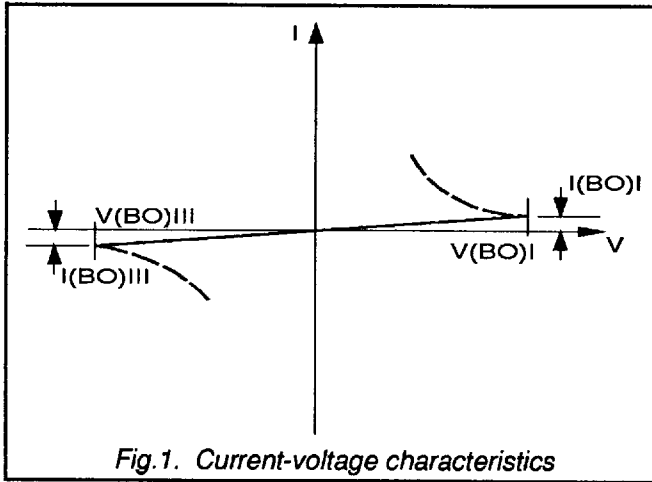

MECHANICAL DATA

