HD74ALVC162831

1-bit 4-bit Address Register / Driver with 3-state Outputs

HITACHI

ADE-205-200 (Z)
Preliminary
1st. Edition
November 1997

Description

This 1-bit to 4-bit address register / driver is designed for 2.3 V to 3.6 V V_{cc} operation. The device is ideal for use in applications in which a single address bus is driving four separate memory locations. The HD74ALVC162831 can be used as a buffer or a register, depending on the logic level of the select (\overline{SEL}) input. When \overline{SEL} is logic high, the device is in the buffer mode. The outputs follow the inputs and are controlled by the two output enable (\overline{OE}) controls. Each \overline{OE} controls two groups of nine outputs. When \overline{SEL} is logic low, the device is in the register mode. The register is an edge triggered D-type flip flop. On the positive transition of the clock (CLK) input, data set up at the A inputs is stored in the internal registers. \overline{OE} controls operate the same as in buffer mode. When \overline{OE} is logic low, the outputs are in a normal logic state (high or low logic level). When \overline{OE} is logic high, the outputs are in the high impedance state. To ensure the high impedance state during power up or power down, \overline{OE} should be tied to V_{cc} through a pullup resistor; the minimum value of the resistor is determined by the current sinking capability of the driver. \overline{SEL} and \overline{OE} do not affect the internal operation of the flip flops. Old data can be retained or new data can be entered while the outputs are in the high impedance state. All outputs, which are designed to sink up to 12 mA, include 26 Ω resistors to reduce overshoot and undershoot.

Features

- $V_{cc} = 2.3 \text{ V to } 3.6 \text{ V}$
- Typical V_{ol} ground bounce $< 0.8 \text{ V}$ ($@V_{cc} = 3.3 \text{ V, } T_a = 25^\circ\text{C}$)
- Typical V_{oh} undershoot $> 2.0 \text{ V}$ ($@V_{cc} = 3.3 \text{ V, } T_a = 25^\circ\text{C}$)
- High output current $\pm 12 \text{ mA}$ ($@V_{cc} = 3.0 \text{ V}$)
- All outputs have equivalent 26 Ω series resistors, so no external resistors are required

HD74ALVC162831

Function Table

Inputs				Output Y
\overline{OE}	\overline{SEL}	CLK	A	
H	X	X	X	Z
L	H	X	L	L
L	H	X	H	H
L	L	↑	L	L
L	L	↑	H	H

H : High level

L : Low level

X : Immaterial

Z : High impedance

↑ : Low to high transition

Pin Arrangement

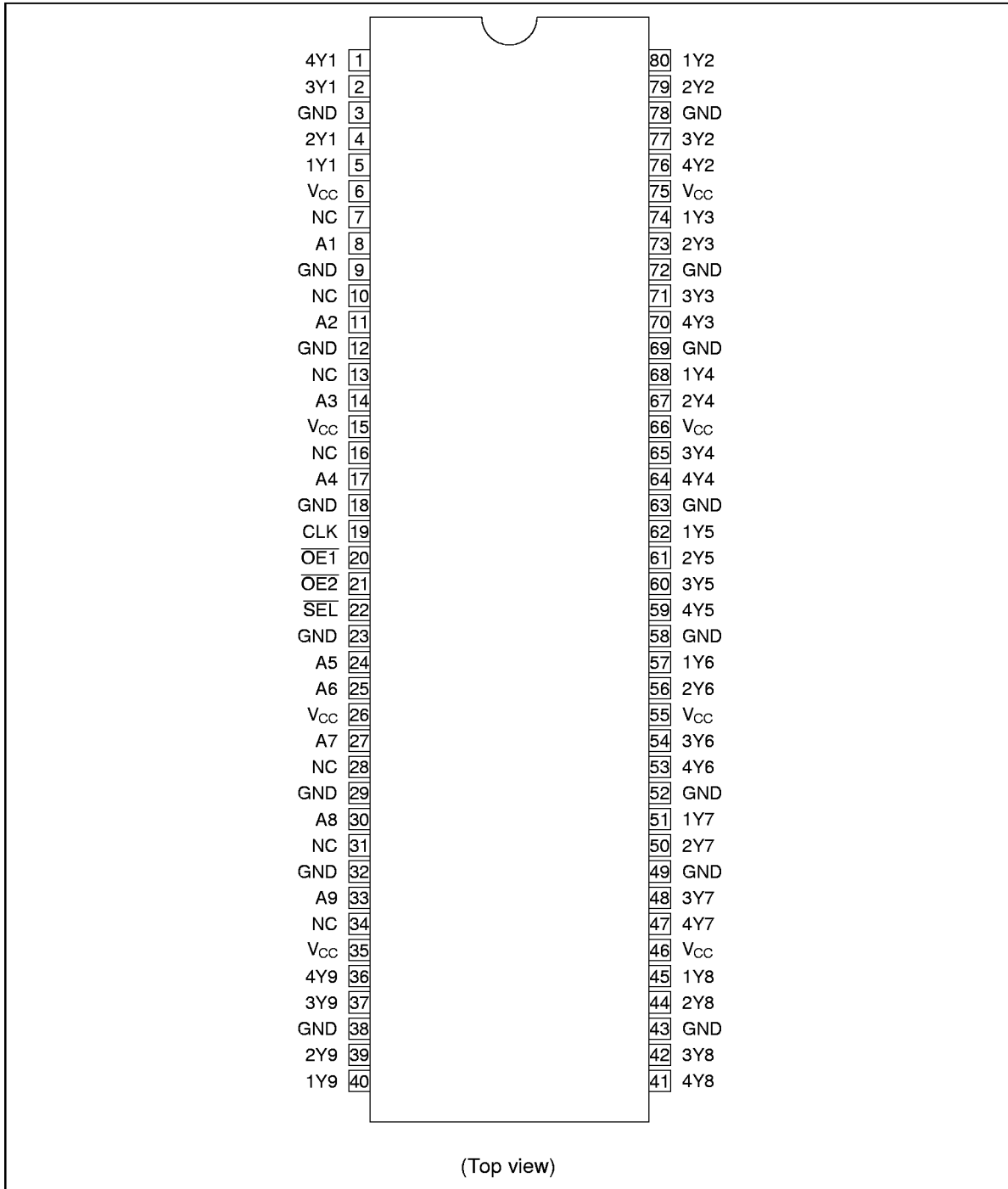

HD74ALVC162831

Absolute Maximum Ratings

Item	Symbol	Ratings	Unit	Conditions
Supply voltage	V_{CC}	-0.5 to 4.6	V	
Input voltage ¹	V_I	-0.5 to 4.6	V	
Output voltage ^{1,2}	V_O	-0.5 to $V_{CC} + 0.5$	V	
Input clamp current	I_{IK}	-50	mA	$V_I < 0$
Output clamp current	I_{OK}	± 50	mA	$V_O < 0$ or $V_O > V_{CC}$
Continuous output current	I_O	± 50	mA	$V_O = 0$ to V_{CC}
V_{CC} , GND current / pin	I_{CC} or I_{GND}	± 100	mA	
Maximum power dissipation at $T_a = 55^\circ\text{C}$ (in still air) ³	P_T	1	W	TVSOP
Storage temperature	T_{stg}	-65 to 150	$^\circ\text{C}$	

Notes: Stresses beyond those listed under "absolute maximum ratings" may cause permanent damage to the device. These are stress ratings only, and functional operation of the device at these or any other conditions beyond those indicated under "recommended operating conditions" is not implied. Exposure to absolute maximum rated conditions for extended periods may affect device reliability.

1. The input and output negative voltage ratings may be exceeded if the input and output clamp current ratings are observed.
2. This value is limited to 4.6 V maximum.
3. The maximum package power dissipation is calculated using a junction temperature of 150°C and a board trace length of 750 mils.

Recommended Operating Conditions

Item	Symbol	Min	Max	Unit	Conditions
Supply voltage	V_{CC}	2.3	3.6	V	
Input voltage	V_I	0	V_{CC}	V	
Output voltage	V_O	0	V_{CC}	V	
High level output current	I_{OH}	—	-6	mA	$V_{CC} = 2.3\text{ V}$
		—	-8		$V_{CC} = 2.7\text{ V}$
		—	-12		$V_{CC} = 3.0\text{ V}$
Low level output current	I_{OL}	—	6	mA	$V_{CC} = 2.3\text{ V}$
		—	8		$V_{CC} = 2.7\text{ V}$
		—	12		$V_{CC} = 3.0\text{ V}$
Input transition rise or fall rate	$\Delta E_t / \Delta E_v$	0	10	ns / V	
Operating temperature	T_a	-40	85	$^\circ\text{C}$	

Note: Unused control inputs must be held high or low to prevent them from floating.

Logic Diagram

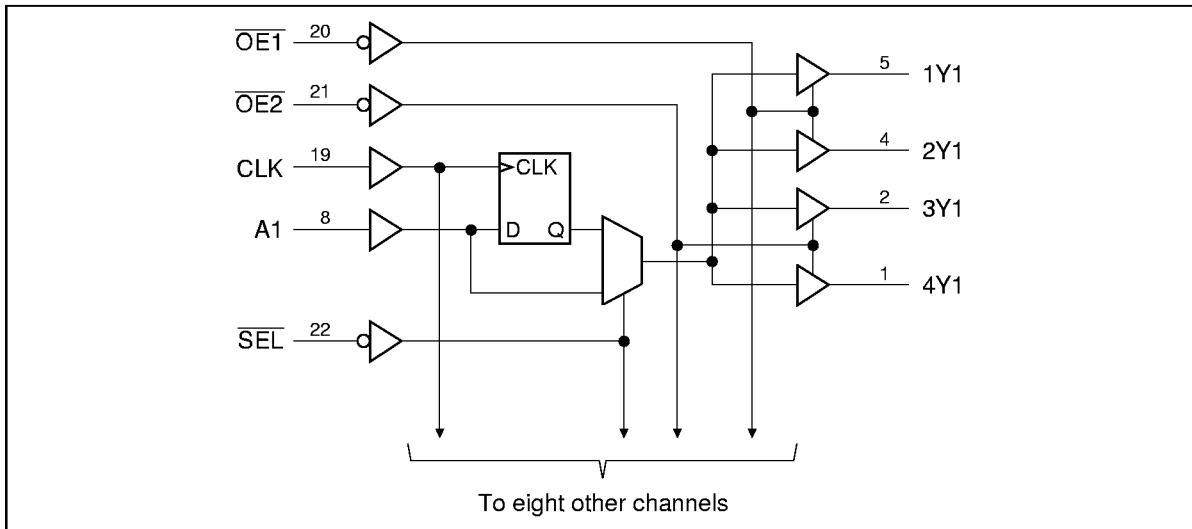

HD74ALVC162831

Electrical Characteristics (Ta = -40 to 85°C)

Item	Symbol	V _{cc} (V)	Min	Max	Unit	Test Conditions
Input voltage	V _{IH}	2.3 to 2.7	1.7	—	V	
		2.7 to 3.6	2.0	—		
	V _{IL}	2.3 to 2.7	—	0.7		
		2.7 to 3.6	—	0.8		
Output voltage	V _{OH}	2.3 to 3.6	V _{cc} -0.2	—	V	I _{OH} = -100 μA
		2.3	1.9	—		I _{OH} = -4 mA, V _{IH} = 1.7 V
		2.3	1.7	—		I _{OH} = -6 mA, V _{IH} = 1.7 V
		2.7	2.4	—		I _{OH} = -6 mA, V _{IH} = 2.0 V
		3.0	2.0	—		I _{OH} = -8 mA, V _{IH} = 2.0 V
		3.0	2.0	—		I _{OH} = -12 mA, V _{IH} = 2.0 V
	V _{OL}	2.3 to 3.6	—	0.2	I _{OL} = 100 μA	
		2.3	—	0.4	I _{OL} = 4 mA, V _{IL} = 0.7 V	
		2.3	—	0.55	I _{OL} = 6 mA, V _{IL} = 0.7 V	
		3.0	—	0.55	I _{OL} = 6 mA, V _{IL} = 0.8 V	
		2.7	—	0.6	I _{OL} = 8 mA, V _{IL} = 0.8 V	
		3.0	—	0.8	I _{OL} = 12 mA, V _{IL} = 0.8 V	
Input current	I _{IN}	3.6	—	±5	μA	V _{IN} = V _{cc} or GND
Off state output current	I _{OZ}	3.6	—	±10	μA	V _{OUT} = V _{cc} or GND
Quiescent supply current	I _{cc}	3.6	—	40	μA	V _{IN} = V _{cc} or GND
	ΔI _{cc}	3.0 to 3.6	—	750	μA	V _{IN} = one input at (V _{cc} -0.6) V, other inputs at V _{cc} or GND

Switching Characteristics (Ta = -40 to 85°C)

Item	Symbol	V _{cc} (V)	Min	Typ	Max	Unit	FROM (Input)	TO (Output)
Maximum clock frequency	f _{max}	2.5±0.2	150	—	—	MHz		
		2.7	150	—	—			
		3.3±0.3	150	—	—			
Propagation delay time	t _{PLH}	2.5±0.2	1.1	—	4.7	ns	A	Y
		2.7	—	—	4.8			
		3.3±0.3	1.5	—	4.3			
	t _{PHL}	2.5±0.2	1.0	—	5.3		CLK	Y
		2.7	—	—	5.3			
		3.3±0.3	1.4	—	4.7			
		2.5±0.2	1.1	—	6.0		SEL	Y
		2.7	—	—	6.2			
		3.3±0.3	1.5	—	4.8			
Output enable time	t _{ZH} t _{ZL}	2.5±0.2	1.0	—	5.9	ns	OE	Y
		2.7	—	—	5.9			
		3.3±0.3	1.1	—	5.1			
Output disable time	t _{HZ} t _{LZ}	2.5±0.2	1.4	—	6.3	ns	OE	Y
		2.7	—	—	5.4			
		3.3±0.3	1.6	—	5.1			
Setup time	t _{su}	2.5±0.2	2.0	—	—	ns		
		2.7	2.0	—	—			
		3.3±0.3	1.6	—	—			
Hold time	t _h	2.5±0.2	0.7	—	—	ns		
		2.7	0.5	—	—			
		3.3±0.3	1.1	—	—			
Pulse width	t _w	2.5±0.2	3.3	—	—	ns		
		2.7	3.3	—	—			
		3.3±0.3	3.3	—	—			
Input capacitance	C _{IN}	3.3	—	4.5	—	pF	Control inputs	
		3.3	—	5.0	—		Data inputs	
Output capacitance	C _O	3.3	—	7.5	—	pF		

HD74ALVC162831

Switching Characteristics (Ta = 0 to 65°C)

Item	Symbol	V _{cc} (V)	Min	Typ	Max	Unit	FROM (Input)	TO (Output)
Propagation delay time	t _{PLH} , t _{PHL}	3.3±0.15	1.9	—	4.5	ns	CLK	Y

Test Circuit

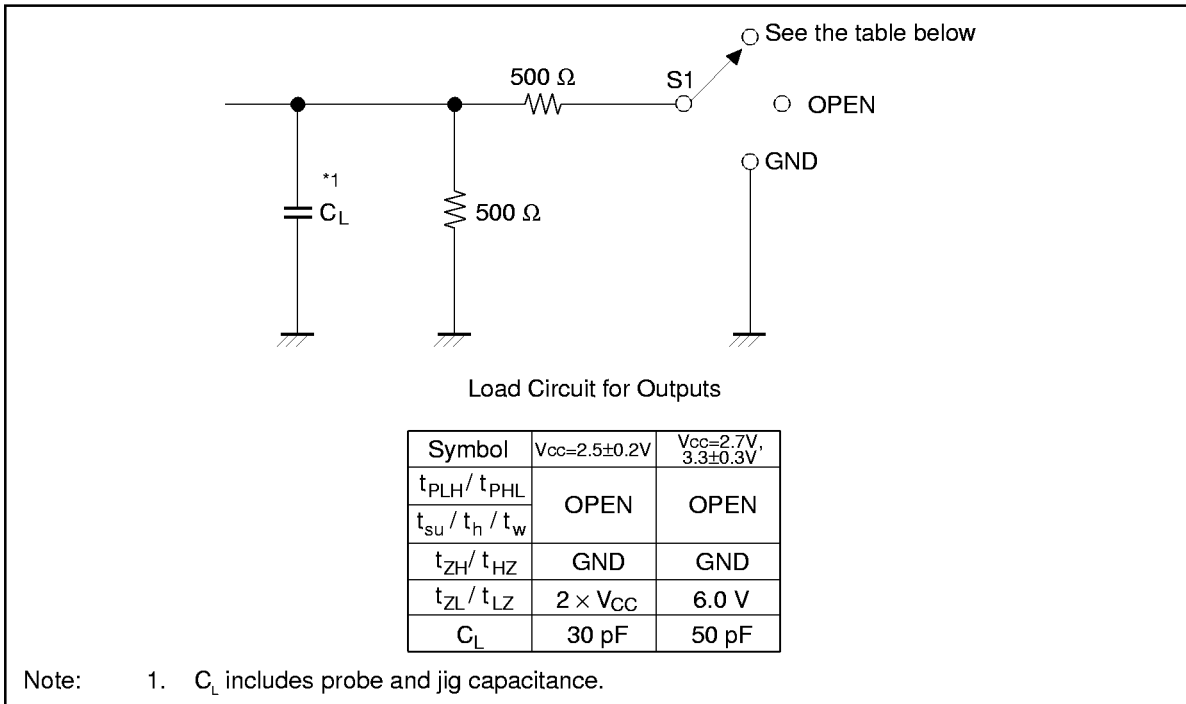

Waveforms – 1

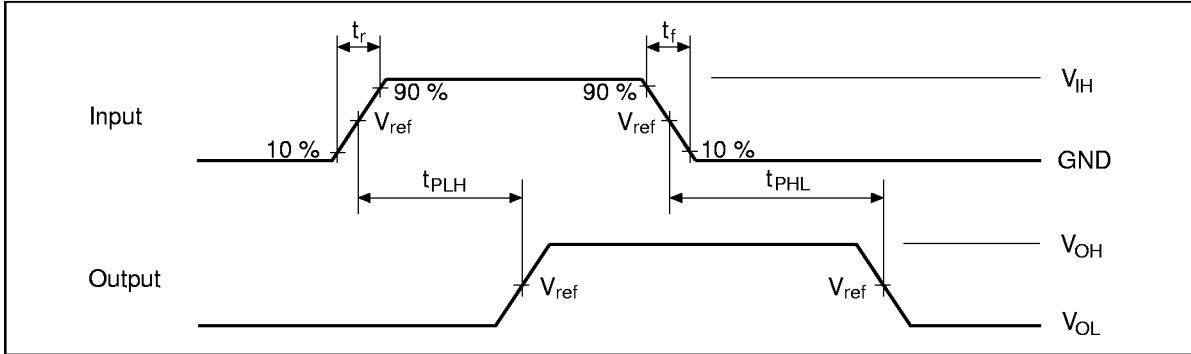

Waveforms – 2

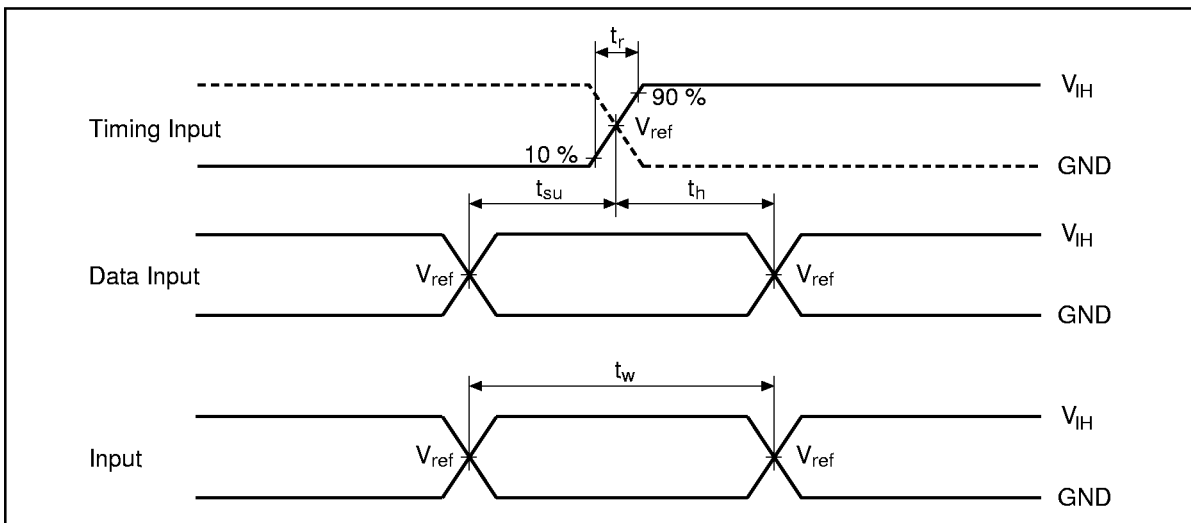

HD74ALVC162831

Waveforms – 3

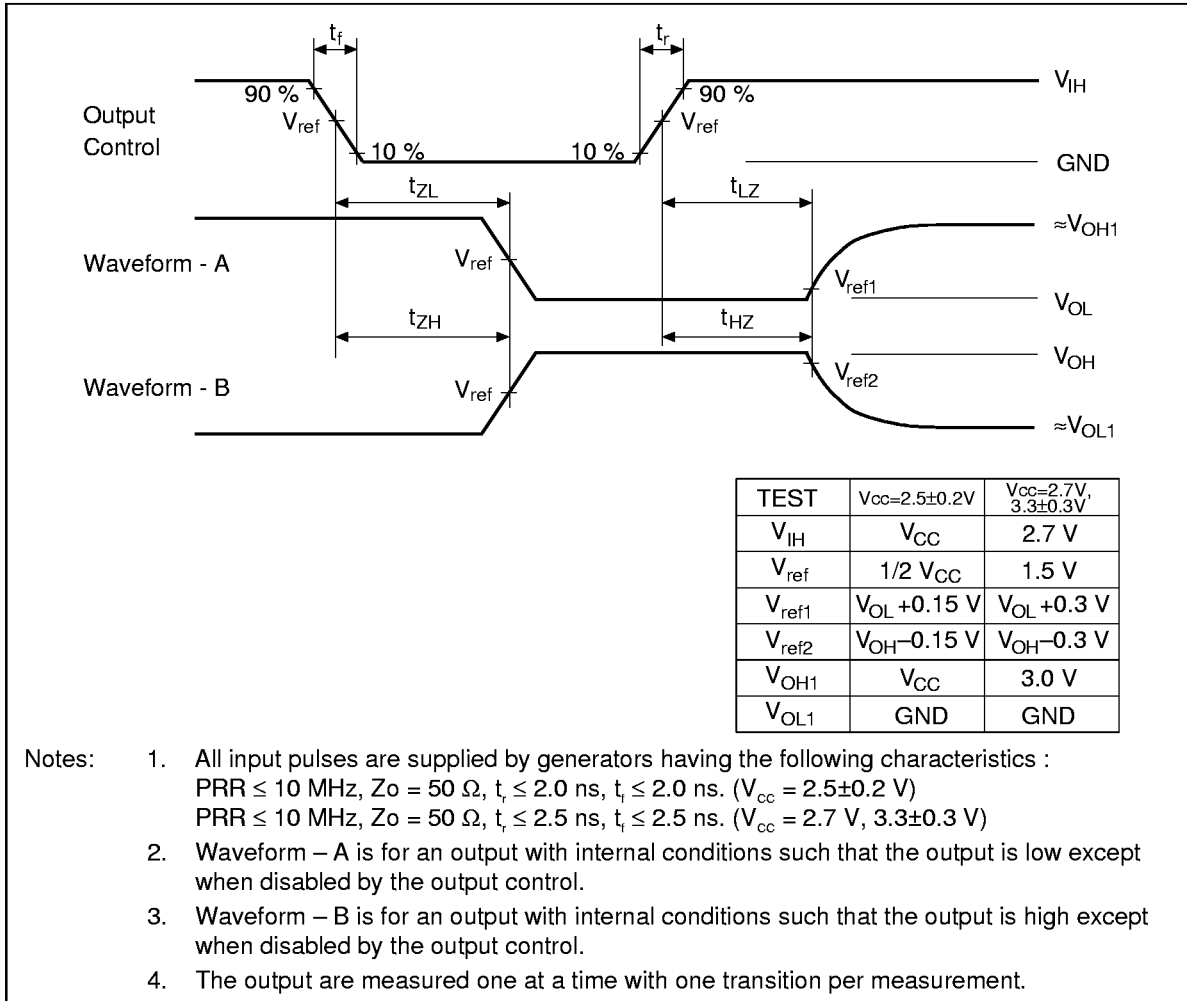

Package Dimensions

Unit : mm

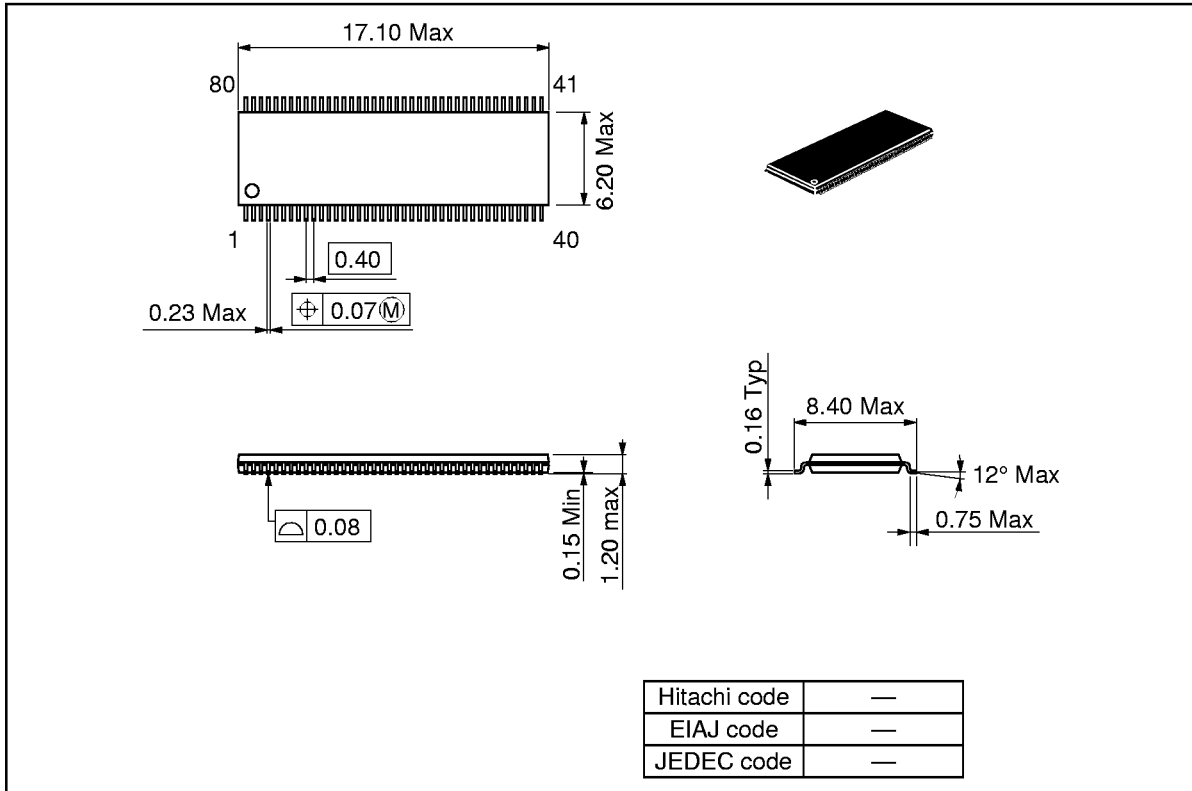

When using this document, keep the following in mind:

1. This document may, wholly or partially, be subject to change without notice.
2. All rights are reserved: No one is permitted to reproduce or duplicate, in any form, the whole or part of this document without Hitachi's permission.
3. Hitachi will not be held responsible for any damage to the user that may result from accidents or any other reasons during operation of the user's unit according to this document.
4. Circuitry and other examples described herein are meant merely to indicate the characteristics and performance of Hitachi's semiconductor products. Hitachi assumes no responsibility for any intellectual property claims or other problems that may result from applications based on the examples described herein.
5. No license is granted by implication or otherwise under any patents or other rights of any third party or Hitachi, Ltd.
6. **MEDICAL APPLICATIONS:** Hitachi's products are not authorized for use in **MEDICAL APPLICATIONS** without the written consent of the appropriate officer of Hitachi's sales company. Such use includes, but is not limited to, use in life support systems. Buyers of Hitachi's products are requested to notify the relevant Hitachi sales offices when planning to use the products in **MEDICAL APPLICATIONS**.

HITACHI

Hitachi, Ltd.

Semiconductor & IC Div.
Nippon Bldg., 2-6-2, Ohte-machi, Chiyoda-ku, Tokyo 100, Japan
Tel: Tokyo (03) 3270-2111
Fax: (03) 3270-5109

For further information write to:

Hitachi America, Ltd.
Semiconductor & IC Div.
2000 Sierra Point Parkway
Brisbane, CA. 94005-1835
U S A
Tel: 415-589-8300
Fax: 415-583-4207

Hitachi Europe GmbH
Continental Europe
Dornacher Straße 3
D-85622 Feldkirchen
München
Tel: 089-9 91 80-0
Fax: 089-9 29 30-00

Hitachi Europe Ltd.
Electronic Components Div.
Northern Europe Headquarters
Whitebrook Park
Lower Cookham Road
Maidenhead
Berkshire SL6 8YA
United Kingdom
Tel: 01628-585000
Fax: 01628-585160

Hitachi Asia Pte. Ltd.
16 Collyer Quay #20-00
Hitachi Tower
Singapore 049318
Tel: 535-2100
Fax: 535-1533

Hitachi Asia (Hong Kong) Ltd.
Unit 706, North Tower,
World Finance Centre,
Harbour City, Canton Road
Tsim Sha Tsui, Kowloon
Hong Kong
Tel: 27359218
Fax: 27306071

Copyright © Hitachi, Ltd., 1997. All rights reserved. Printed in Japan.