

# CCM03 MK II with Auto Lock cover



A new range of CCM03 connectors have been developed to interface with SIM/SAM cards as defined by GSM11-11 and ENV1375-1. The connectors are available with a hinged metallic cover and have been designed to provide an easier open/lock function and side card entry.

## Features

- Available with 6 cross contacts which are designed to give a consistently reliable normal force over the life of the connector.
- The hinged metallic cover can automatically lock by pressure.
- Side entry of the card ensures easier positioning of the card into the connector.
- Insulated blade switch version available for detection card when cover is closed.
- The molding is polarized so that the cover can only be closed if the card is correctly inserted.
- Inspection slots allow an electrical test to be made without opening the cover.
- With tape and reel packaging as standard, the connectors are designed to be automatically pick-and-place.
- The moldings are made from high-temperature thermoplastics suited to infrared and convection soldering processes.
- Robustly formed printed circuit tails allow a coplanarity of  $\pm 0,05$  mm to be maintained.

## Construction

Contacts	Copper alloy
Contacts finish	Gold over nickel
PC tail plating	Tin lead (2 $\mu$ min)
Molding	High temp. thermoplastic, UL94V-0
Cover	Stainless steel

## Mechanical Data

Number of Contacts	6
Mechanical life	10,000 cycles min
Contact force	0.35 N min / 0.50 N max
Vibration	Frequency 10 to 500 Hz. Acceleration 50m/s <sup>2</sup> Duration 6 hours - amplitude 0.35 mm (0.014) Max electrical discontinuity 1 $\mu$ s

## Contact Electrical Data

Insulation resistance	1,000 M $\Omega$ min
Resistance	100 m $\Omega$ max
Current rating	10 $\mu$ A min / 1 A max
Dielectric strength	750 Vrms min

## Switch Electrical Data

Card detection switch	Normally open
Contact resistance	100 m $\Omega$ max
Dielectric strength	250 Vrms min
Current rating	1mA min / 10m A max
Maximum power	0.2 VA

## Environmental Data

Operating temperature	-40°C to +85°C
Soldering temperature	Temperature/time profile acc. to CECC00802 para. 6.1, Fig. 3 with peak temperature 250°C
Damp heat	IEC 512 test number 11c (10 days)
Salt mist	IEC 512 test number 11f (96 hours)

## Ordering Code

Part Number	Number of Contacts	Cover	Card Presence Switch	Quantity per reel
CCM03-3517	6	Side Hinged	No	1300
CCM03-3518	6	Front Hinged	Yes (insulated)	1300
CCM03-3529	6	Front Hinged	No	1300

## Packaging

5 reels per box.

# CCM03 MK II with Auto Lock cover

## Dimensional Drawings

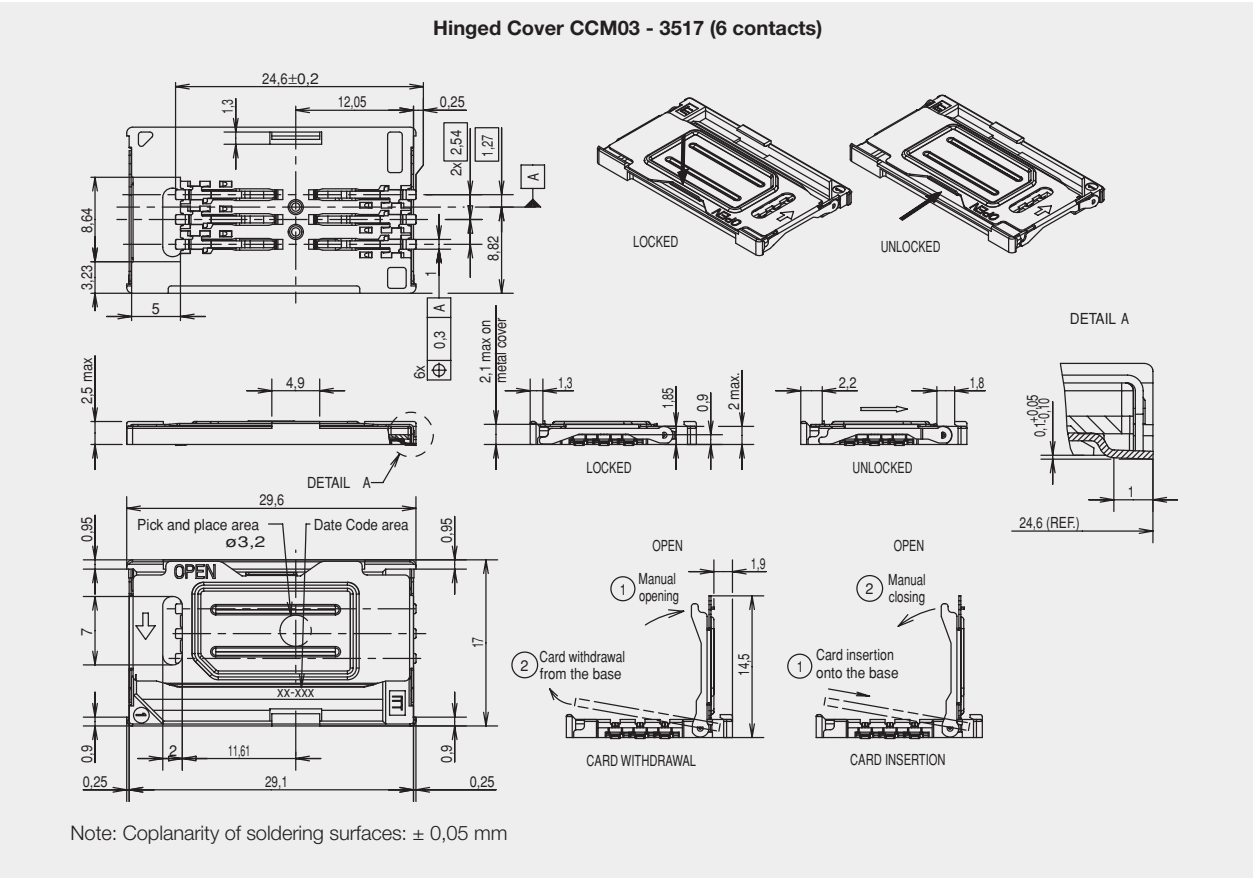

## PCB Layout

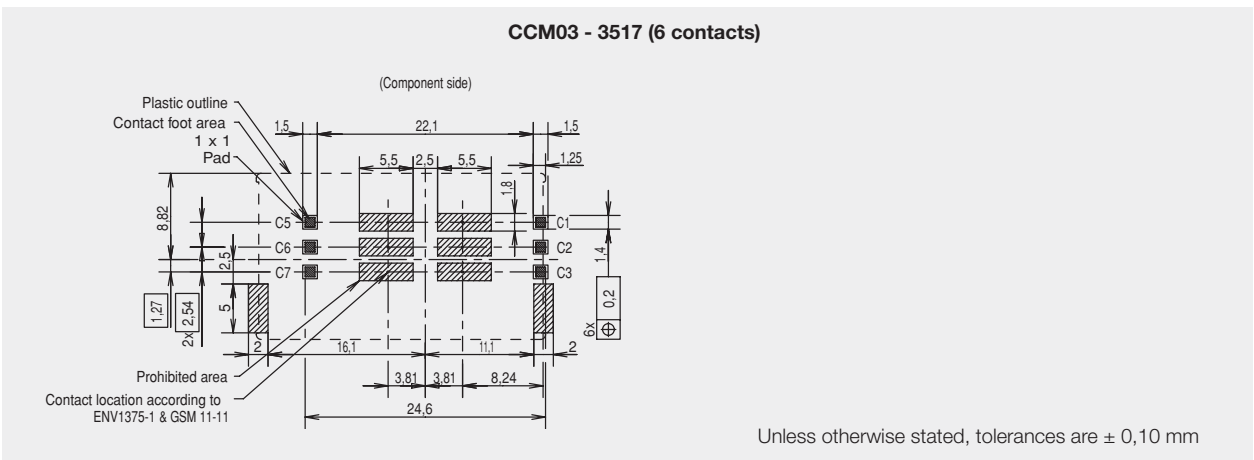

# CCM03 MK II with Auto Lock cover

## Dimensional Drawings

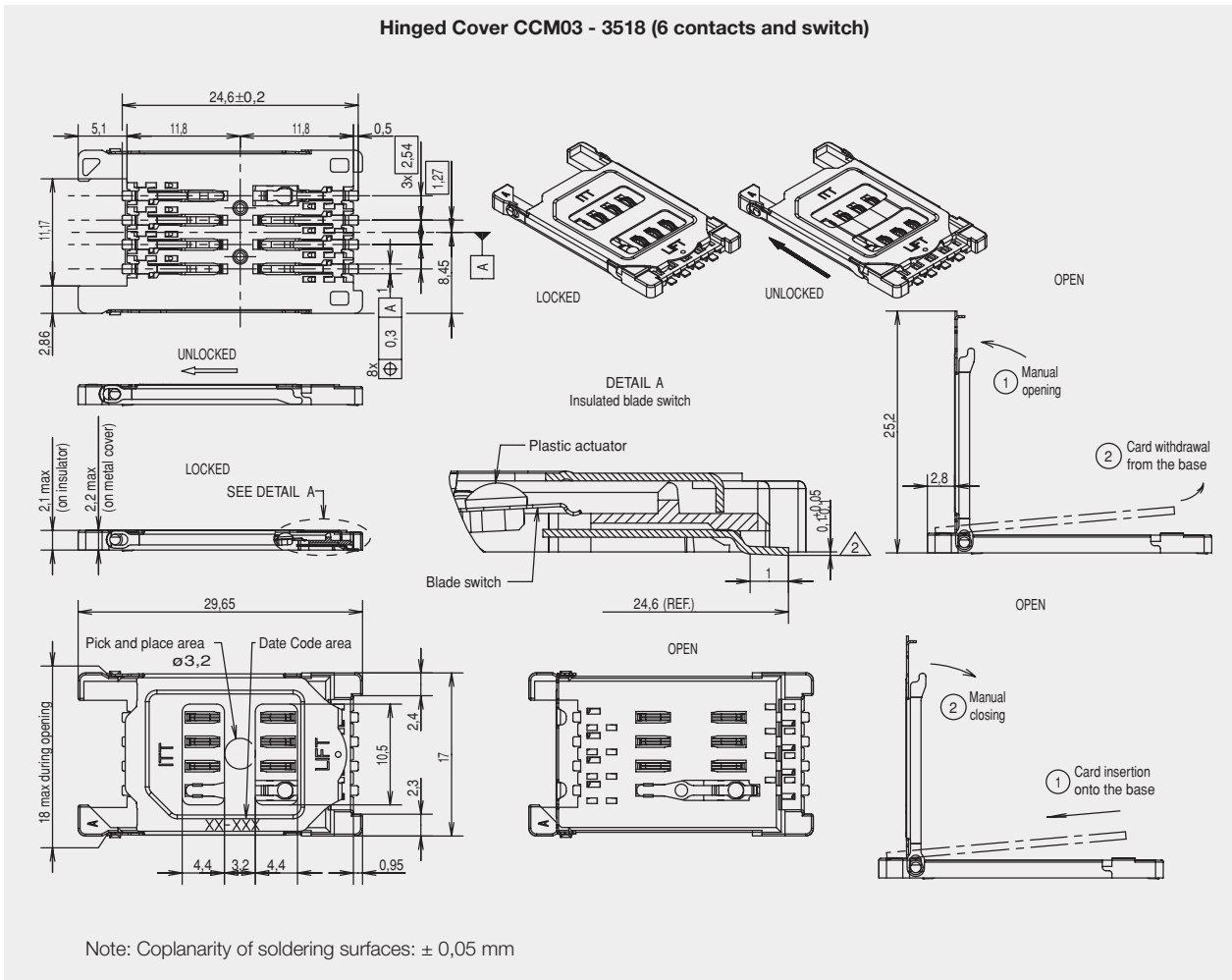

## PCB Layout

**CCM03 - 3518 (6 contacts and switch)**  
**CCM03-3529 (without switch) layout is similar except SW pads**

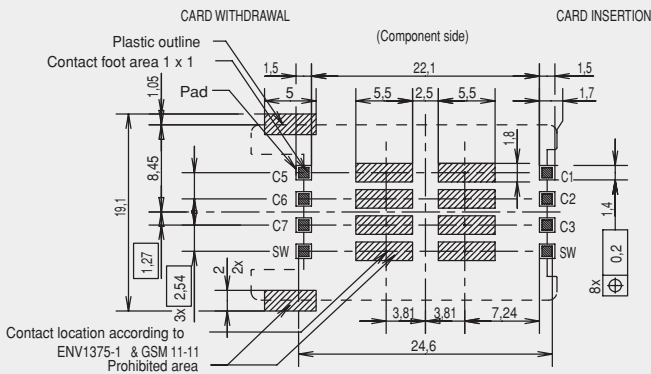

Unless otherwise stated, tolerances are  $\pm 0,10$  mm