

Trimable Resistor Chip

Size 0805

0/-20% and 0/-30%

2338 734 90...

FEATURES

- Reduced size of final equipment
- Lower assembly costs
- Specific electrical requirements (such as improved performance at high frequencies)

DESCRIPTION

The resistors are constructed on a high grade ceramic body (aluminum oxide). Internal metal electrodes are added at each end and a connection is made between using a resistive metal glaze. The approximate resistor values are dependent on the composition of the glaze.

The resistive layer is covered with a translucent protective coat. Two end terminations are added along with a nickel barrier coat. For ease of soldering, the outer layer of these end terminations is a tin/lead alloy.

Trimming Instructions with YAG-laser showing typical values for:

- Cutting speed = 30 to 300 mm/s
- Laser power = 1 to 8 Watts
- Maximum trimming length = 60% of resistor film width
- Minimum Distance between end term. and trimming cut = 0.20 mm
- Minimum distance between cuts (double-cut) = 0.50 mm

QUICK REFERENCE DATA

Resistance Range	1 Ω to 10 MΩ; E24 Series
Resistance Tolerance	0/-20% and 0/-30%
Temperature Coefficient	$1 \Omega \leq R \leq 10 \Omega$ $\leq \pm 500 \text{ ppm}/^\circ\text{C}$ $11 \Omega \leq R \leq 10 \text{ M}\Omega$ $\leq \pm 100 \text{ ppm}/^\circ\text{C}$
Abs. Max. Dissipation at $T_{\text{amb}} = 70^\circ\text{C}$	0.100 W
Max. Continuous Operating Voltage	150 V (DC or RMS)
Operating Temperature Range	-55°C to + 125°C
Basic Specification	IEC 115-1
Stability after: Load, 1000 hrs at $T_{\text{amb}} = 70^\circ\text{C}$ Climatic Tests for $R \leq 1 \Omega$ for $R \geq 1 \Omega$ Resistance to Soldering Heat Short Time Overload, 300 V max	$\Delta R/R \text{ Max: } 1.0\% + 0.05 \Omega$ $\Delta R/R \text{ Max: } 1.5\% + 0.05 \Omega$ $\Delta R/R \text{ Max: } 3.0\% + 0.10 \Omega$ $\Delta R/R \text{ Max: } 0.5\% + 0.05 \Omega$ $\Delta R/R \text{ Max: } 1.0\% + 0.10 \Omega$

Note

These stability data are valid for non-trimmed resistors. Some properties can change after trimming because of insufficient lacquering.

MECHANICAL DATA

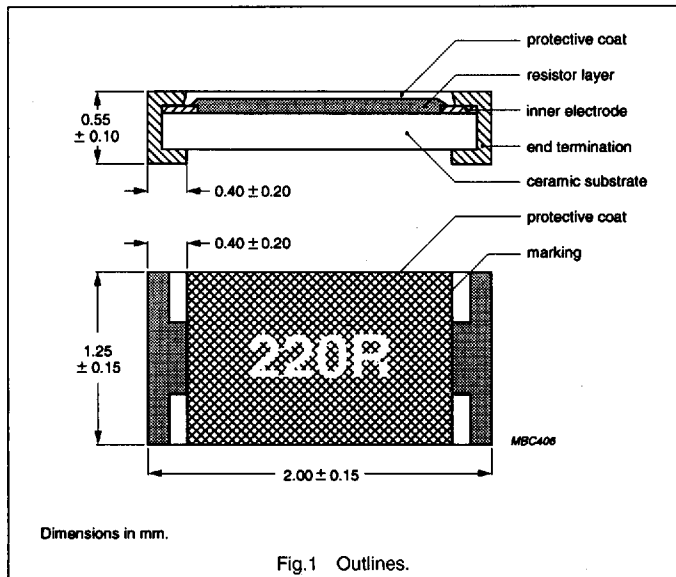

Fig.1 Outlines.

Trimmable Resistor Chip
Size 0805
0/-20% and 0/-30%

2338 734 90...

MASS: 0.55 g per 100 units

PROTECTION OF LASER CUT

Protection of the laser cut is necessary with epoxy-phenol lacquers, epoxy resins, or silicon-alkyd resins for stability in load and humidity tests.

MOUNTING

The rectangular shape and accurate dimensions of this device make it suitable for use with automatic placement machines. The resistors can be mounted on either ceramic substrates or print-circuit boards (PCB's) and their protective coating enables "face down" mounting.

The devices may be connected to the circuit using a number of techniques. The robust construction of the device allows it to be immersed in a solder bath of 260°C for up to one minute. This allows the Surface Mounted Resistors to be mounted on one side of a PCB and other discrete components on the reverse side (mixed PCB's).

SOLDERING CONDITIONS

Surface Mounted Resistors are tested for solderability at a temperature of 235°C for a period of 2 seconds. The test condition for no leaching is 260°C for 60 seconds. Typical examples of soldering processes that provide reliable joints without any damage are given in Figs. 2, 3, and 4.

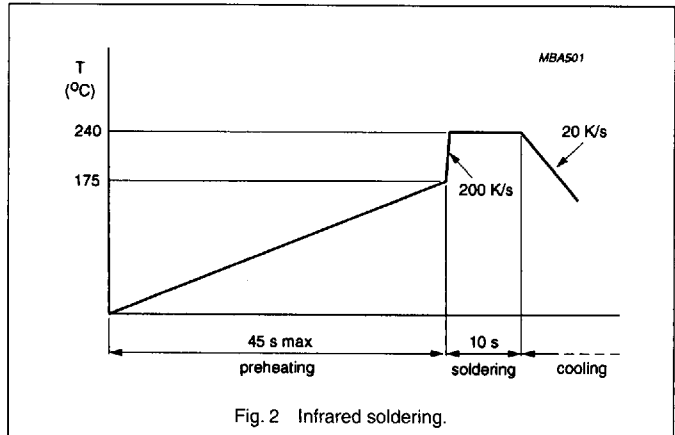

Fig. 2 Infrared soldering.

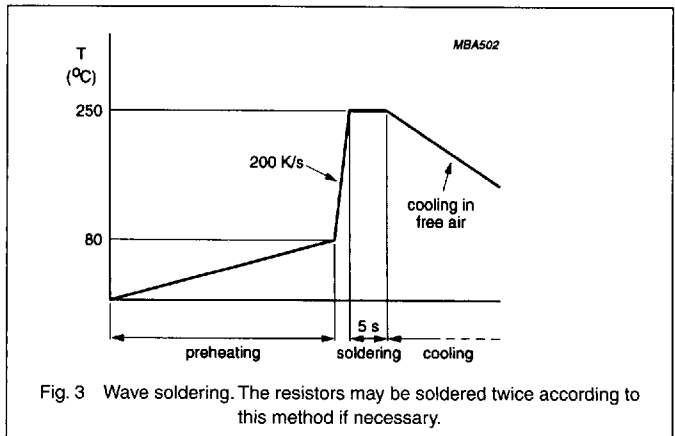

Fig. 3 Wave soldering. The resistors may be soldered twice according to this method if necessary.

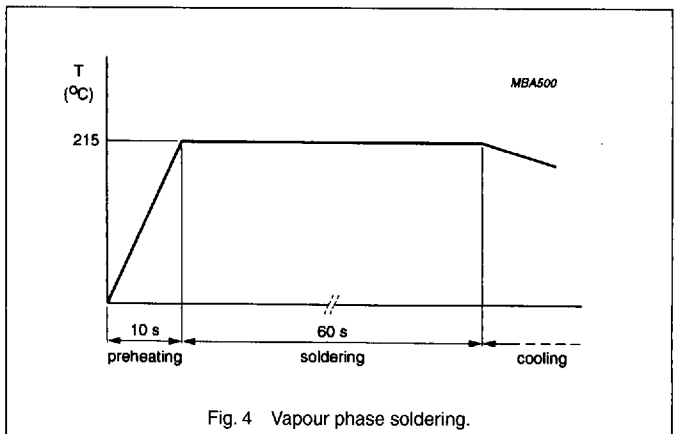

Fig. 4 Vapour phase soldering.

Trimmable Resistor Chip
Size 0805
0/-20% and 0/-30%

2338 734 90...

MARKING

These resistors are not marked. The packing is marked and includes resistance value, tolerance, catalogue number, quantity, production period, batch number, and code of origin.

ELECTRICAL DATA

Standard values of nominal resistance are taken from the E24 series with a tolerance of 0/-20% and 0/-30%.

The maximum continuous working voltage (DC or RMS) is 150 V. This is the maximum voltage that may be continuously applied to the resistor element.

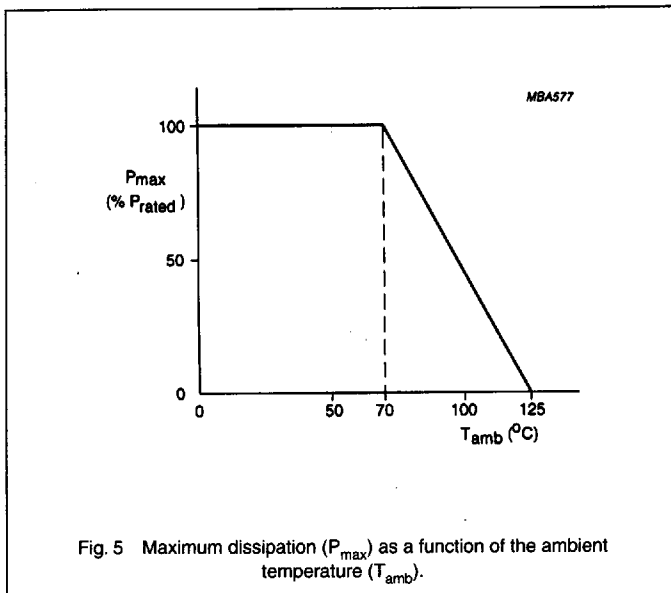

DISSIPATION

The rated power that the resistor can dissipate depends on the operating temperature. See Fig. 5.

ORDERING INFORMATION

International Part Number

Table 1 The resistor part numbers start with 2322 724. Subsequent digits are issued on request and are specific for each value.

Resistance Range	Tol ± %	Series	2338 734 90...
			Cardboard Tape
			5000 reel
			On Request
1 Ω to 10 MΩ	0/-20	E24	
1 Ω to 10 MΩ	0/-30	E24	

SPECIFICATION PROTOCOL

This specification for the 2338 734 chip resistor is defined as a "Preliminary Specification". A Preliminary Specification contains preliminary data. Therefore, the data presented is not final and may change at a later date.