



Obsolescence Notice

This product is obsolete.

This information is available for your convenience only.

For more information on Zarlink's obsolete products and replacement product lists, please visit http://products.zarlink.com/obsolete_products/

SL1451

WIDEBAND PLL FM DETECTOR FOR SATELLITE TV

The SL1451 is a phase locked loop demodulator for use in wideband FM systems. It is intended for use with an IF input frequency from 300MHz to 700MHz in satellite receivers. It consists of an input RF amplifier, signal level detector, UHF phase detector UHF oscillator and video/loop amplifier. Both positive and negative going video outputs are available.

FEATURES

- Complete PLL System for Wideband FM Demodulator
- Noise Threshold Performance: 8dB (Typ.)
- Low External Component Count
- Positive and Negative going Video Output
- Demodulates FM Signals with up to 28MHz p-p Deviation

APPLICATIONS

- DBS Receivers
- Wideband Data Communications Demodulation

ORDERING INFORMATION

SL1451 NA DP (16-lead plastic DIL package)

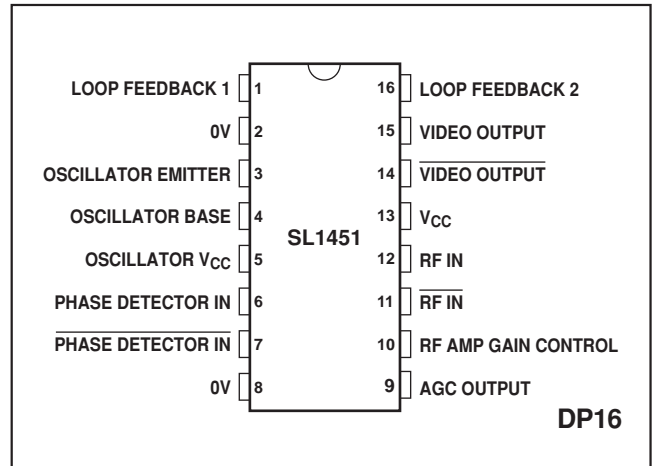

Fig. 1 Pin connections - top view

ABSOLUTE MAXIMUM RATINGS

Operating temperature range	-10°C to +80°C
Supply voltage, V _{CC}	11V
Storage temperature	-55°C to +150°C
Junction temperature	+175°C

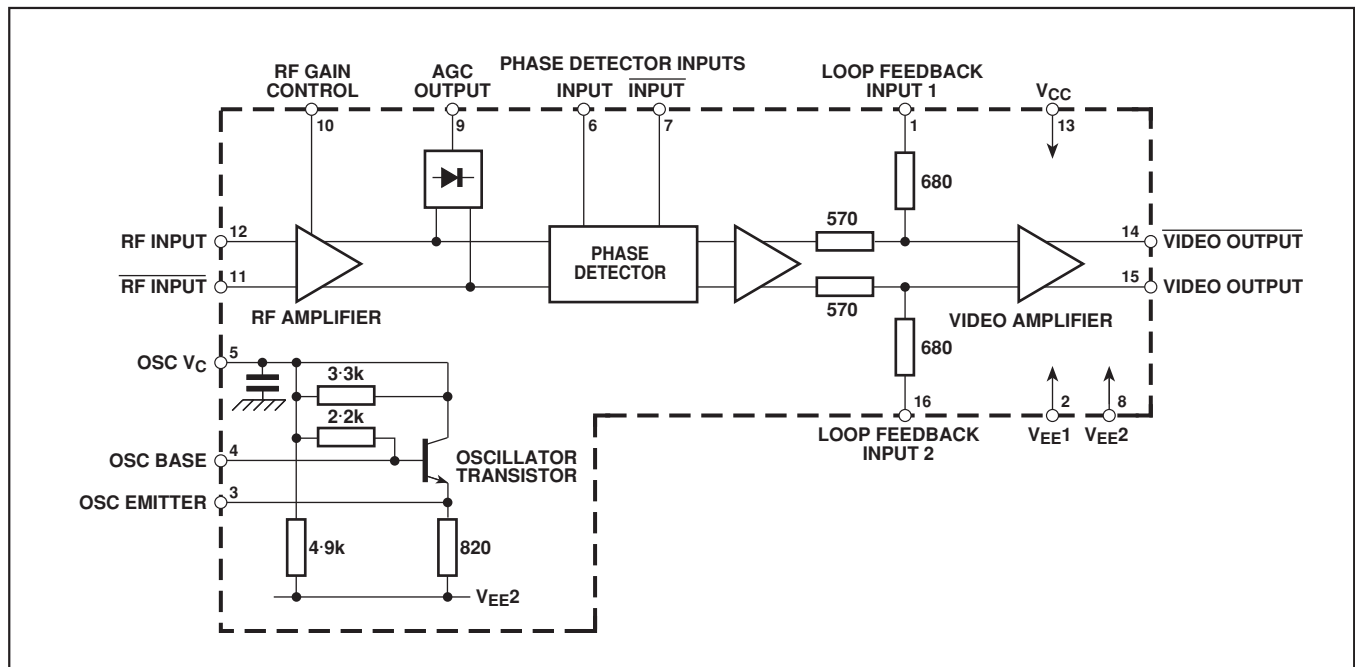

Fig. 2 Block diagram

ELECTRICAL CHARACTERISTICS

These characteristics are guaranteed over the following conditions (unless otherwise stated):

$$T_{AMB} = +25^{\circ}\text{C}, V_{CC} = 7.4\text{V to }9\text{V}$$

Characteristic	Pin	Value			Units	Conditions
		Min.	Typ.	Max.		
Supply current	13,5	40	55	70	mA	No input signal -20dBm input signal See note 1 21.4MHz p-p deviation See note 2
Supply voltage	13,5	7.4	8.2	9	V	
Minimum oscillator frequency			300		MHz	
Maximum oscillator frequency			700		MHz	
Phase detector input level from oscillator	6,7	400	70	100	mV	
RF input level	11,12	12.5	40	125	mV	
Phase detector gain			0.5		V/Radian	
AGC output	9		300		μA	
			140		μA	
Oscillator lock range			50		MHz	
VCO slope			14		MHz/V	
Video output voltage	14,15		1.5		V p-p	
Intermodulation products			-40		dBm	
Video bandwidth			18		MHz	

NOTES

- All characteristics from Oscillator Lock Range to Video Bandwidth are measured using the application circuit Fig. 3.
- Signal 1: 4.433MHz, deviation = 21.4MHz p-p.
Signal 2: 6MHz, deviation = 3MHz p-p.

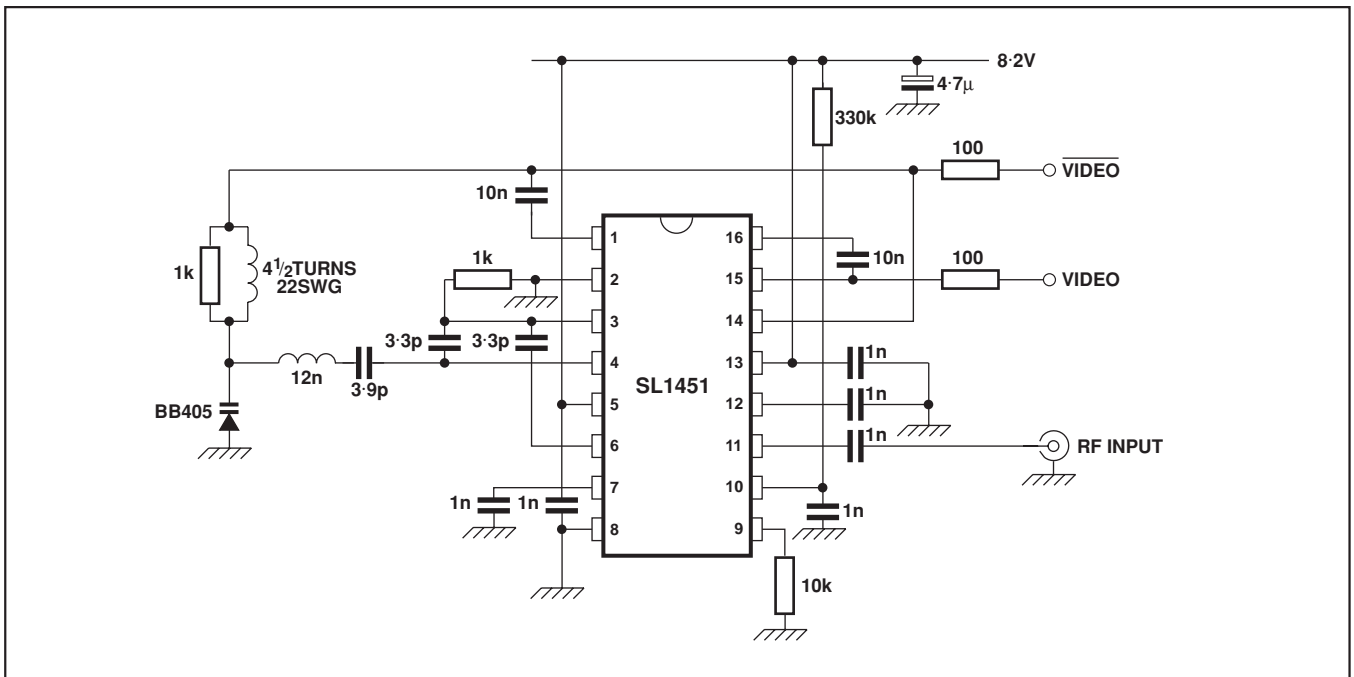
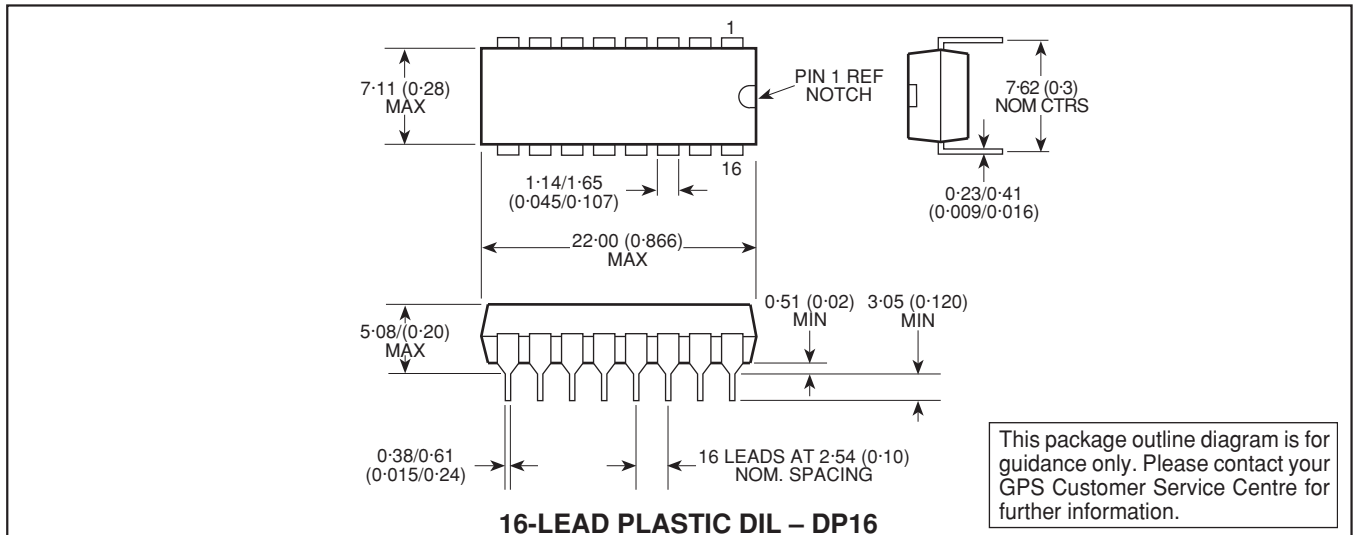

Fig. 3 Typical application circuit

NOTES

PACKAGE DETAILS

Dimensions are shown thus: mm (in)

**HEADQUARTERS OPERATIONS****GEC PLESSEY SEMICONDUCTORS**

Cheney Manor, Swindon,
Wiltshire SN2 2QW, United Kingdom.
Tel: (0793) 518000
Fax: (0793) 518411

GEC PLESSEY SEMICONDUCTORS

P.O. Box 660017
1500 Green Hills Road,
Scotts Valley, CA95067-0017
United States of America.
Tel (408) 438 2900
Fax: (408) 438 5576

CUSTOMER SERVICE CENTRES

- **FRANCE & BENELUX** Les Ulis Cedex Tel: (1) 64 46 23 45 Tx: 602858F
Fax : (1) 64 46 06 07
 - **GERMANY** Munich Tel: (089) 3609 06-0 Tx: 523980 Fax : (089) 3609 06-55
 - **ITALY** Milan Tel: (02) 66040867 Fax: (02) 66040993
 - **JAPAN** Tokyo Tel: (03) 3296-0281 Fax: (03) 3296-0228
 - **NORTH AMERICA Integrated Circuits and Microwave Products**, Scotts Valley, USA
Tel: (408) 438 2900 Fax: (408) 438 7023.
Hybrid Products, Farmingdale, USA Tel (516) 293 8686 Fax: (516) 293 0061.
 - **SOUTH EAST ASIA** Singapore Tel: (65) 3827708 Fax: (65) 3828872
 - **SWEDEN** Stockholm Tel: 4687029770 Fax: 4686404736
 - **UK, EIRE, DENMARK, FINLAND & NORWAY**
Swindon Tel: (0793) 518510 Tx: 444410 Fax : (0793) 518582
- These are supported by Agents and Distributors in major countries world-wide.

© GEC Plessey Semiconductors 1993 Publication No. DS2042 Issue No. 2.1 September 1993

This publication is issued to provide information only which (unless agreed by the Company in writing) may not be used, applied or reproduced for any purpose nor form part of any order or contract nor to be regarded as a representation relating to the products or services concerned. No warranty or guarantee express or implied is made regarding the capability, performance or suitability of any product or service. The Company reserves the right to alter without prior knowledge the specification, design or price of any product or service. Information concerning possible methods of use is provided as a guide only and does not constitute any guarantee that such methods of use will be satisfactory in a specific piece of equipment. It is the user's responsibility to fully determine the performance and suitability of any equipment using such information and to ensure that any publication or data used is up to date and has not been superseded. These products are not suitable for use in any medical products whose failure to perform may result in significant injury or death to the user. All products and materials are sold and services provided subject to the Company's conditions of sale, which are available on request.



**For more information about all Zarlink products
visit our Web Site at
www.zarlink.com**

Information relating to products and services furnished herein by Zarlink Semiconductor Inc. trading as Zarlink Semiconductor or its subsidiaries (collectively "Zarlink") is believed to be reliable. However, Zarlink assumes no liability for errors that may appear in this publication, or for liability otherwise arising from the application or use of any such information, product or service or for any infringement of patents or other intellectual property rights owned by third parties which may result from such application or use. Neither the supply of such information or purchase of product or service conveys any license, either express or implied, under patents or other intellectual property rights owned by Zarlink or licensed from third parties by Zarlink, whatsoever. Purchasers of products are also hereby notified that the use of product in certain ways or in combination with Zarlink, or non-Zarlink furnished goods or services may infringe patents or other intellectual property rights owned by Zarlink.

This publication is issued to provide information only and (unless agreed by Zarlink in writing) may not be used, applied or reproduced for any purpose nor form part of any order or contract nor to be regarded as a representation relating to the products or services concerned. The products, their specifications, services and other information appearing in this publication are subject to change by Zarlink without notice. No warranty or guarantee express or implied is made regarding the capability, performance or suitability of any product or service. Information concerning possible methods of use is provided as a guide only and does not constitute any guarantee that such methods of use will be satisfactory in a specific piece of equipment. It is the user's responsibility to fully determine the performance and suitability of any equipment using such information and to ensure that any publication or data used is up to date and has not been superseded. Manufacturing does not necessarily include testing of all functions or parameters. These products are not suitable for use in any medical products whose failure to perform may result in significant injury or death to the user. All products and materials are sold and services provided subject to Zarlink's conditions of sale which are available on request.

Purchase of Zarlink's I²C components conveys a licence under the Philips I²C Patent rights to use these components in and I²C System, provided that the system conforms to the I²C Standard Specification as defined by Philips.

Zarlink and the Zarlink Semiconductor logo are trademarks of Zarlink Semiconductor Inc.

Copyright 2001, Zarlink Semiconductor Inc. All Rights Reserved.

TECHNICAL DOCUMENTATION - NOT FOR RESALE
