



M.S.KENNEDY CORP.

600V/450A
HALF BRIDGE PEM

4800

FEATURES:

- Half Bridge Configuration
- 600V Rated Voltage
- 450A Continuous Output Current
- Internal Zener Clamps on Gates
- Proprietary Encapsulation Provides Near Hermetic Performance
- HI-REL Screening Available (Modified 38534)
- Light Weight Domed ALSIC Baseplate
- Robust Mechanical Design for Hi-Rel Applications
- Ultra-Low Inductance Internal Layout
- Withstands 96 Hours HAST and Thermal Cycling (-55°C to +125°C)
- High Side Collector Sense Pin for De-Sat Detection

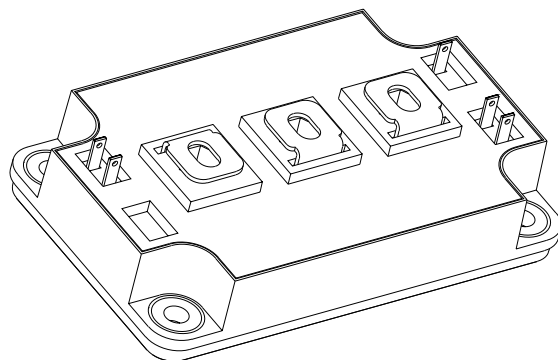

DESCRIPTION:

The MSK4800 is one of a family of plastic encapsulated modules (PEM) developed specifically for use in military, aerospace and other severe environment applications. The half bridge configuration and 600 volt/450 amp rating make it ideal for use in high current motor drive and inverter applications. The Aluminum Silicon Carbide (AlSiC) baseplate offers superior flatness and light weight; far better than the copper or copper alloys found in most high power plastic modules. The high thermal conductivity materials used to construct the MSK4800 allow high power outputs at elevated baseplate temperatures. Our proprietary coating, SEES™ - Severe Environment Encapsulation System - protects the internal circuitry of MSK PEM's from moisture and contamination, allowing them to pass the rugged environmental screening requirements of military and aerospace applications. MSK PEM's are also available with industry standard silicone gel coatings for a lower cost option.

EQUIVALENT SCHEMATIC

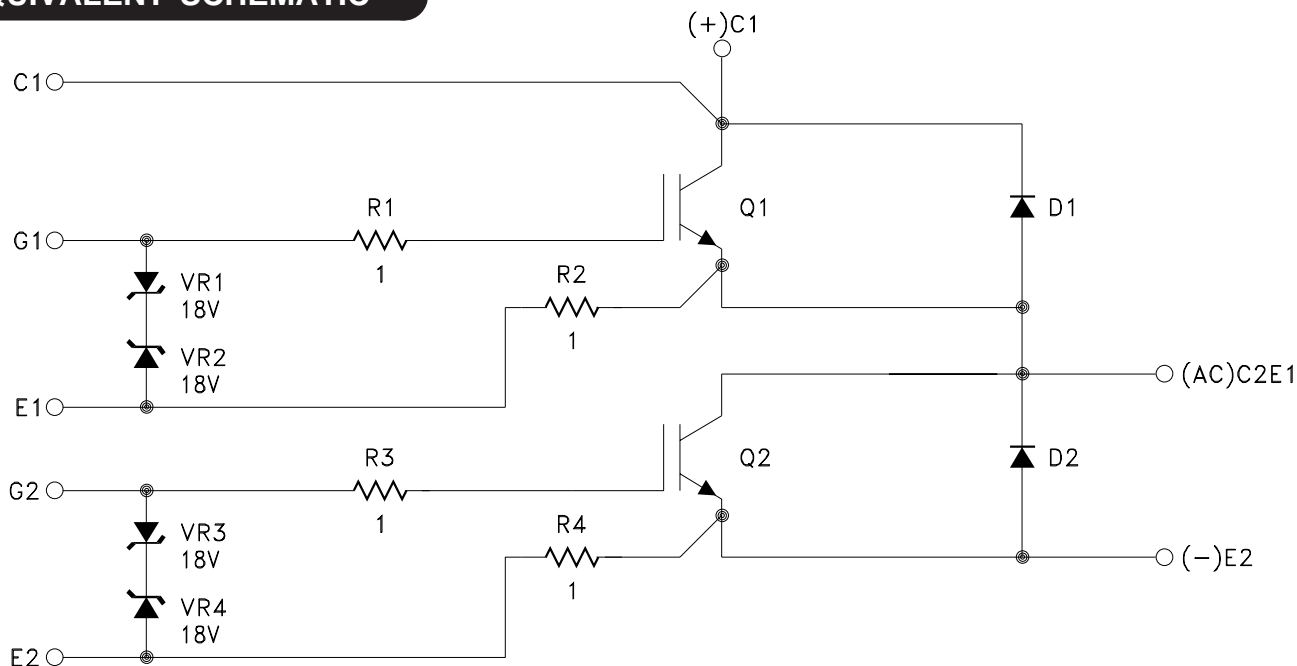

TYPICAL APPLICATIONS

- Motor Drives
- Inverters

ABSOLUTE MAXIMUM RATING ^⑧

VCE	Collector to Emitter Voltage	600V
VGE	Gate to Emitter Voltage	±20V
IOUT	Current (Continuous)	450A
IOUTP	Current Pulsed (1mS)	900A
VCASE	Case Isolation Voltage	2500 V

TST	Storage Temperature Range ^⑨	-55°C to +125°C
TJ	Junction Temperature	150°C
TC	Case Operating Temperature Range	
	MSK4800H	-55°C to +125°C
	MSK4800	-40°C to +85°C

ELECTRICAL SPECIFICATIONS

Parameter ^⑥	Test Conditions	Group A Subgroup	MSK4800H			MSK4800			Units
			Min.	Typ.	Max.	Min.	Typ.	Max.	
Collector-Emitter Saturation Voltage	IC = 450A, VGE = 15V	1	-	1.9	2.6	-	1.9	2.7	V
		2	-	1.8	2.6	-	1.8	2.7	V
		3	-	2.1	2.8	-	2.1	2.9	V
Collector-Emitter Leakage Current	VCE = 600V, VGE = 0V	1	-	0.05	1.5	-	0.05	2.0	mA
		2	-	2.5	18	-	2.5	18	mA
		① 3	-	0.05	1.5	-	0.05	2.0	mA
Gate Threshold Voltage	IC = 45mA, VCE = VGE	1	4.0	5.3	8.1	4.0	5.3	8.5	V
		2	4.0	4.5	7.5	4.0	4.5	7.5	V
		3	4.0	6.0	8.1	4.0	6.0	8.5	V
Gate Leakage Current	VCE = 0V, VGE = ±15V	1	-10	0.2	10	-12	0.2	12	uA
		2	-10	0.4	10	-12	0.4	12	uA
		3	-10	0.1	10	-12	0.1	12	uA
Diode Forward Voltage	IC = 450A	1	-	1.5	2.6	-	1.5	2.7	V
		2	-	1.3	2.6	-	1.3	2.7	V
		3	-	1.6	2.8	-	1.6	2.9	V
Total Gate Charge ^①	V = 300V, IC = 450A	4	-	2500	4300	-	2500	4300	nC
Turn-On Delay ^①	V = 300V, IC = 450A, RG = 20Ω	4	-	790	900	-	790	900	nS
Rise Time ^①	V = 300V, IC = 450A, RG = 20Ω	4	-	400	700	-	400	700	nS
E(on)	V = 300V, IC = 450A, RG = 20Ω, VGE = -7/+12V	4	-	87.2	-	-	87.2	-	mJ
	V = 300V, IC = 450A, RG = 20Ω, VGE = -7/+15V	4	-	50.5	-	-	50.5	-	mJ
	V = 300V, IC = 450A, RG = 20Ω, VGE = -7/+12V	5	-	89.2	-	-	89.2	-	mJ
	V = 300V, IC = 450A, RG = 20Ω, VGE = -7/+15V	5	-	51.3	-	-	51.3	-	mJ
E(off)	V = 300V, IC = 450A, RG = 10Ω, VGE = -7/+12V	4	-	30.5	-	-	30.5	-	mJ
	V = 300V, IC = 450A, RG = 10Ω, VGE = -7/+12V	5	-	39.7	-	-	39.7	-	mJ
Turn-Off Delay ^①	V = 300V, IC = 450A, RG = 10Ω	4	-	1.5	2.1	-	1.5	2.5	uS
Fall Time ^①	V = 300V, IC = 450A, RG = 10Ω	4	-	120	300	-	120	300	nS
Diode Reverse Recovery Time ^①	IE = 450A, di/dt = 900A/uS	4	-	75	170	-	75	170	nS
Diode Reverse Recovery Charge ^①	IE = 450A, di/dt = 900A/uS	4	-	3.0	6.0	-	3.0	6.0	uC
Thermal Resistance ^①	IGBT @ TJ = 125°C	4	-	0.06	0.08	-	0.06	0.09	°C/W
	DIODE @ TJ = 125°C	4	-	0.1	0.15	-	0.1	0.16	°C/W

NOTES:

- ① Guaranteed by design but not tested. Typical parameters are representative of actual device performance but are for reference only.
- ② Industrial grade devices shall be tested to subgroup 1 unless otherwise specified.
- ③ HI-REL grade devices ("H" suffix) shall be 100% tested to subgroups 1, 2 and sample tested to subgroup 3.
- ④ Subgroup 4 testing available upon request.
- ⑤ Subgroup 1, 4 TA = +25°C
2, 5 TA = +125°C
3, 6 TA = -55°C
- ⑥ All specifications apply to both the upper and lower sections of the half bridge.
- ⑦ VGE=15V unless otherwise specified.
- ⑧ Continuous operation at or above absolute maximum ratings may adversely effect the device performance and/or life cycle
- ⑨ Internal solder reflow temperature is 180°C, do not exceed.

THERMAL CALCULATIONS

Power dissipation and maximum allowable temperature rise involve many variables working together. Collector current, PWM duty cycle and switching frequency all factor into power dissipation. DC losses or "ON-TIME" losses are simply $V_{CE(SAT)} \times \text{Collector Current} \times \text{PWM duty cycle}$. For the MSK4800, $V_{CE(SAT)}=2.6V$ max., and at 450 amps and a PWM duty cycle of 30%, DC losses equal 351 watts. Switching losses vary proportionally with switching frequency. The MSK4800 typical switching losses at $V_{CE}=300V$ and $I_{CE}=450A$ are about 117.7mJ, which is simply the sum of the turn-on switching loss and the turn-off switching loss. Multiplying the switching frequency times the switching losses will result in a power dissipation number for switching. The MSK4800, at 5KHz, will exhibit switching power dissipation of 589 watts. The total losses are the sum of DC losses plus switching losses, or in this case, 940 watts total. $940 \text{ watts} \times 0.08^{\circ}\text{C/W}$ thermal resistance equals 75 degrees of temperature rise between the case and the junction. Subtracting 75°C from the maximum junction temperature of 150°C equals 75°C maximum case temperature for this example.

$$V_{CE(SAT)} \times I_C \times \text{PWM duty cycle} = 2.6V \times 450 \text{ amps} \times 30\% = 357 \text{ watts DC losses}$$

$$\text{Turn-on switching loss} + \text{Turn-off switching loss} = \text{Total switching losses} = 30.5 + 87.2 = 117.7\text{mJ}$$

$$\text{Total switching loss} \times \text{PWM frequency} = \text{Total switching power dissipation} = 117.7\text{mJ} \times 5\text{KHz} = 589 \text{ watts}$$

$$\text{Total power dissipation} = \text{DC losses} + \text{switching losses} = 351 + 589 = 940 \text{ watts}$$

$$\text{Junction temperature rise above case} = \text{Total power dissipation} \times \text{thermal resistance}$$

$$940 \text{ watts} \times 0.08^{\circ}\text{C/W} = 75^{\circ}\text{C temperature rise above case}$$

$$\text{Maximum junction temperature} - \text{junction temperature rise} = \text{maximum baseplate temperature}$$

$$150^{\circ}\text{C} - 75^{\circ}\text{C} = 75^{\circ}\text{C}$$

TYPICAL PERFORMANCE CURVES

TYPICAL OUTPUT CHARACTERISTICS

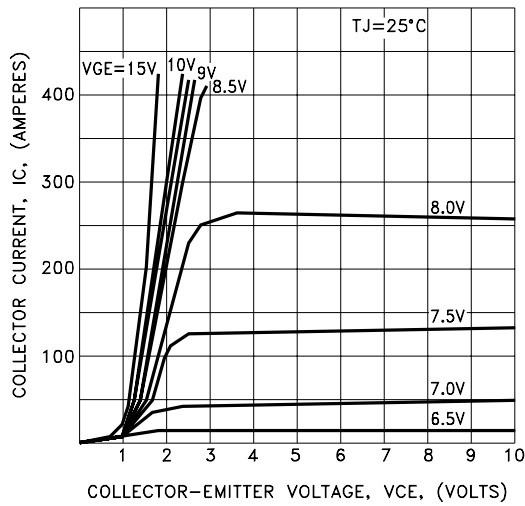

COLLECTOR-EMITTER SATURATION VOLTAGE CHARACTERISTICS

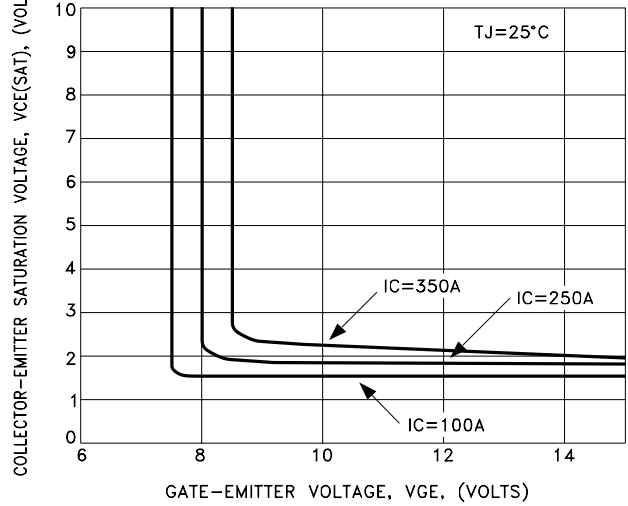

FREE-WHEEL DIODE FORWARD CHARACTERISTICS

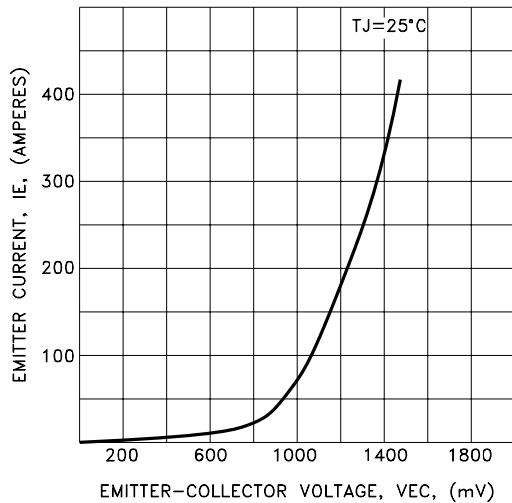

SWITCHING CHARACTERISTICS

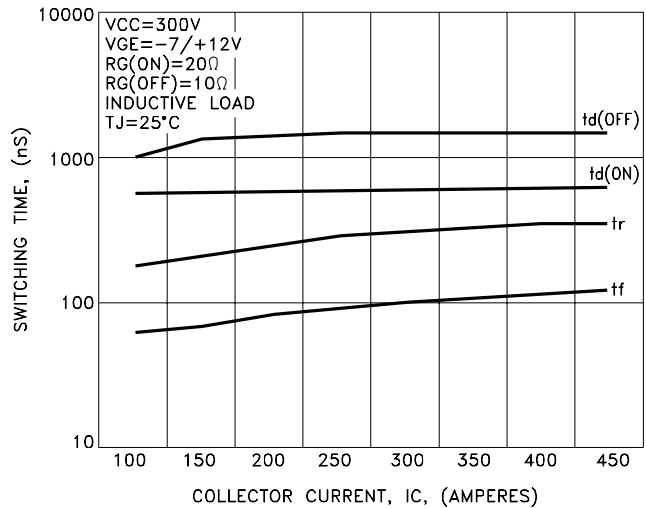

REVERSE RECOVERY CHARACTERISTICS

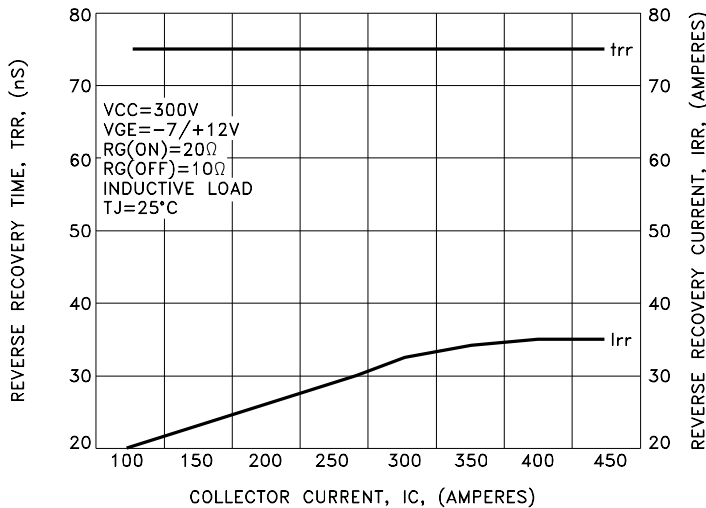

SWITCHING LOSS vs. COLLECTOR CURRENT

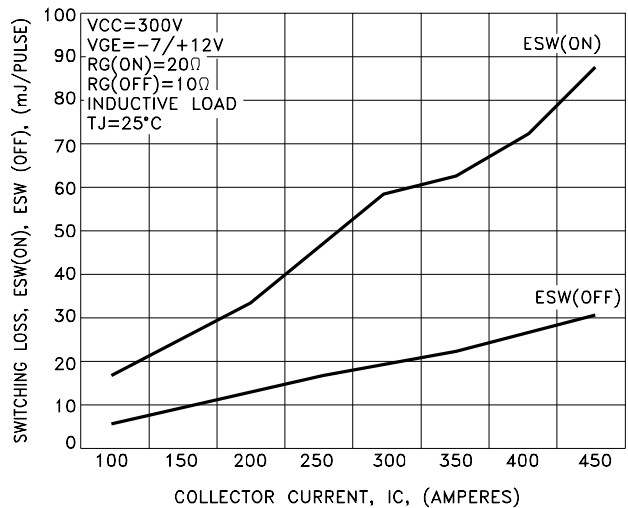

SCREENING CHART

OPERATION	INDUSTRIAL	H SUFFIX
QUALIFICATION (MODIFIED)	NO	YES
ELEMENT EVALUATION	NO	YES
CLEAN ROOM PROCESSING	YES	YES
NON DESTRUCT BOND PULL SAMPLE	YES	YES
CERTIFIED OPERATORS	NO	YES
MIL LINE PROCESSING	YES	YES
MAX REWORK SPECIFIED	NO	YES
ENCAPSULANT	GEL COAT	SEES™
PRE-CAP VISUAL	YES - INDUSTRIAL	YES - CLASS H
TEMP CYCLE (-55°C TO +125°C)	NO	YES
BURN-IN	NO	YES - 160 HOURS
ELECTRICAL TESTING	YES - 25°C	YES - FULL TEMP
EXTERNAL VISUAL	YES - SAMPLE	YES
XRAY	NO	NO
PIN FINISH	NI	NI

NOTE: ADDITIONAL SCREENING IS AVAILABLE SUCH AS XRAY, CSAM, MECHANICAL SHOCK, ETC. CONTACT FACTORY FOR QUAL STATUS.

MECHANICAL SPECIFICATIONS

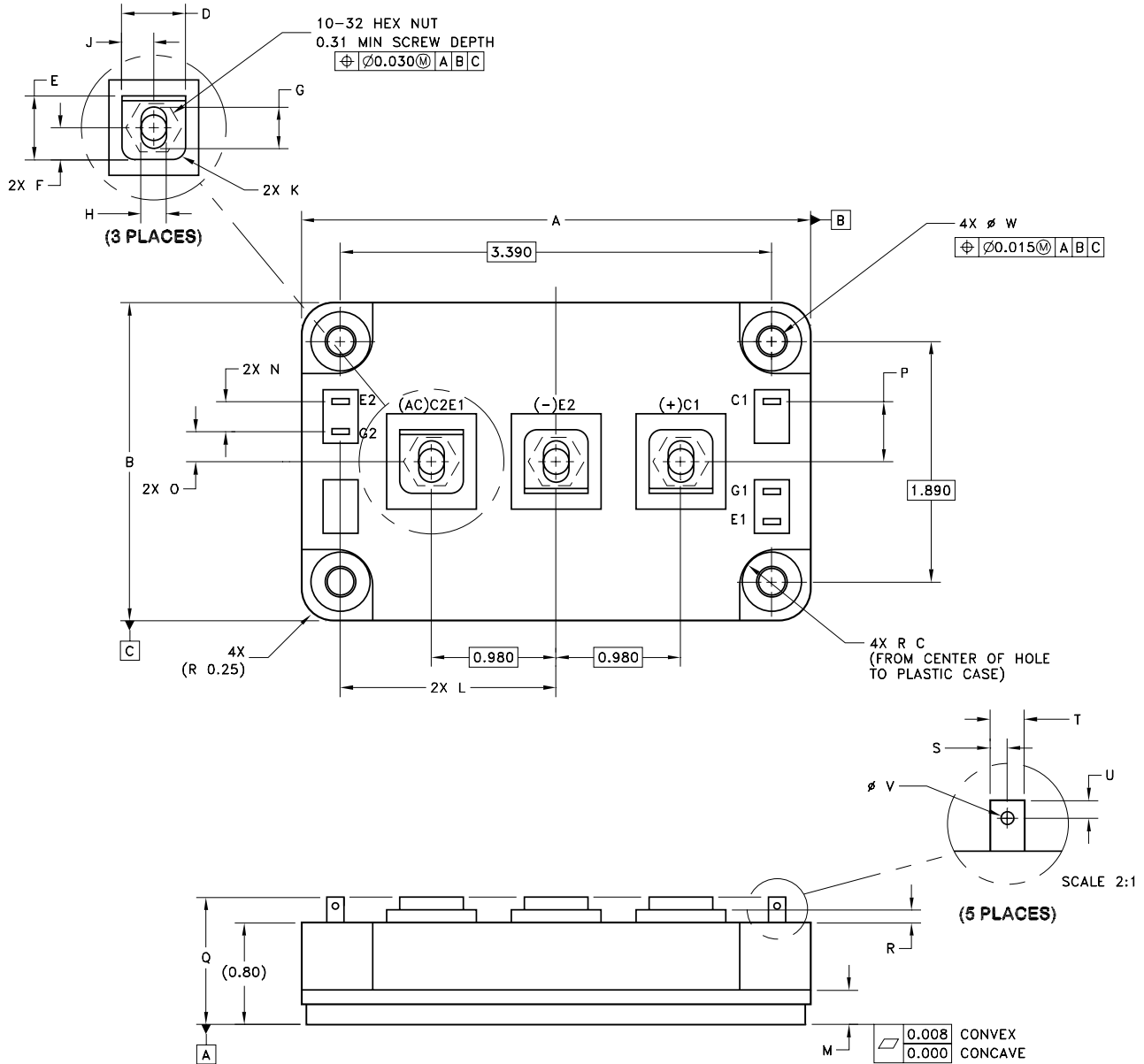

WEIGHT = 272 GRAMS MAX.

ALL DIMENSIONS ARE SPECIFIED IN INCHES

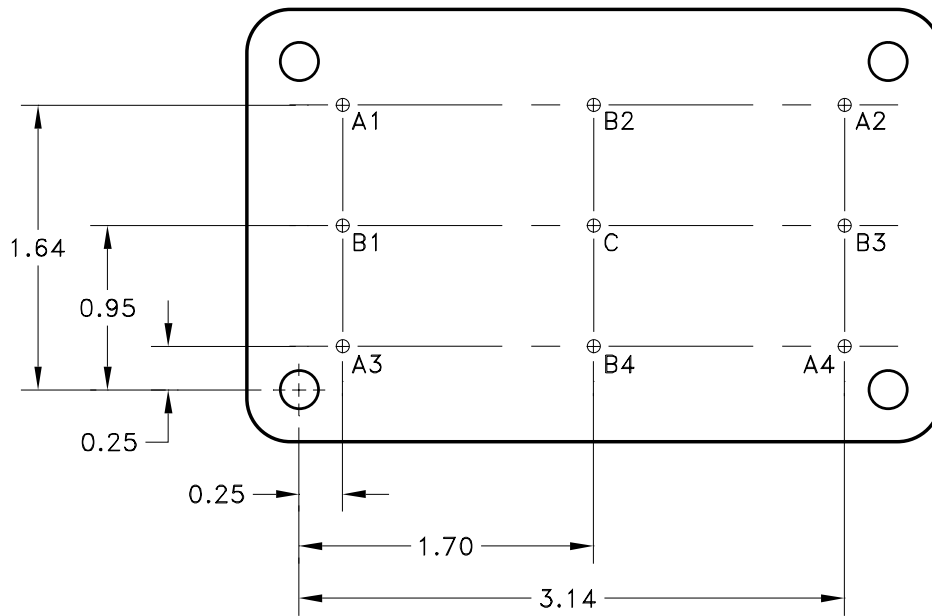

**POWER MODULE
BOTTOM VIEW
(NOT TO SCALE)**

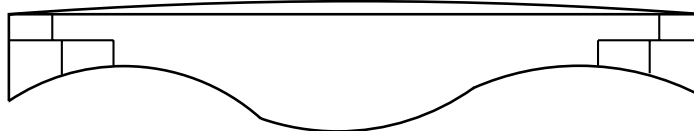

**POWER MODULE SIDE VIEW
(EXAGGERATED DOME)
(NOT TO SCALE)**

CONVEX BASEPLATE PROFILE (FROM POINT C)

REF	ZMIN.	ZMAX.
A1	0.000	0.008
A2	0.000	0.008
A3	0.000	0.008
A4	0.000	0.008
B1	0.000	0.008
B2	0.000	0.008
B3	0.000	0.008
B4	0.000	0.008

ALL DIMENSIONS ARE SPECIFIED IN INCHES

ORDERING INFORMATION



THE ABOVE EXAMPLE IS A MILITARY SCREENED MODULE.

REVISION HISTORY

REV	STATUS	DATE	DESCRIPTION
H	Released	11/14	Format update, add internal note and clarify mechanical specifications.

M.S. Kennedy Corp.
Phone (315) 701-6751
FAX (315) 701-6752
www.mskennedy.com

The information contained herein is believed to be accurate at the time of printing. MSK reserves the right to make changes to its products or specifications without notice, however, and assumes no liability for the use of its products. Please visit our website for the most recent revision of this datasheet.