

Model 144

OCXO – Ultra Low Power, DIL-14

Features

- 8 to 120 MHz Frequency Range
- Very short warm-up time
- ECO-friendly, 150 mW power consumption
- Low profile

Applications

- Portable wireless communications
- Synthesizers
- Battery powered applications



Part Dimensions: 21.8 x 15.3 x 7.5 mm

Description

CTS **Model 144** uses the internal heating resonator (IHR) technology with arrangement of the whole oven control system together with the crystal plate inside the T08 vacuum holder to radically reduce the OCXO size, power consumption, and warm-up time. In addition, the **Model 144** offers excellent temperature stability, low phase noise and aging rate despite its miniature size and extremely low power consumption. The oscillator has the performance of high-end OCXOs which use conventional oven designs.

Ordering Information – Table 1

Model	Stability	Temperature Range	Supply Voltage	Aging	Frequency, MHz
144	V	G	E	C	16.384

Code	Stability	Code	Temp range	Code	Supply	Code	Per day	Per year	For Frequencies
T	±50 ppb	A	0 to 50°C	D	5.0V ±5%	L	0.3 ppb	0.03 ppm	≥8MHz
30	±30 ppb	B	0 to 70°C	E	3.3V ±5%	J	0.5 ppb	0.05 ppm	≥20MHz
U	±20 ppb	C	-10 to 60°C			C	1 ppb	0.1 ppm	≥50MHz
V	±10 ppb	D	-20 to 70°C			I	1.5 ppb	0.15 ppm	≥80MHz
W	±5 ppb	E	-30 to 70°C			K	2.5 ppb	0.25 ppm	≥100MHz
		G	-40 to 85°C			B	2 ppb	0.2 ppm	
						F	3 ppb	0.3 ppm	
						A	5 ppb	0.5 ppm	

Available Frequency Stabilities over Operating Temperature Ranges

Order Code	Temperature Range	Stability				
		T 50ppb	30 30ppb	U 20ppb	V 10ppb	W 5ppb
A	0 to 50°C	*	*	*	*	B
B	0 to 70°C	*	*	*	C	B
C	-10 to 60°C	*	*	*	C	B
D	-20 to 70°C	*	*	*	C	A
E	-30 to 70°C	*	*	C	B	A
G	-40 to 85°C	*	D	C	B	

Stability Legend

- * = Available for all frequencies
- A = Available only for frequencies ≤10MHz
- B = Available only for frequencies ≤30MHz
- C = Available only for frequencies ≤50MHz
- D = Available only for frequencies ≤100MHz

Part Number Example: 144-VGEC-16.384MHz



Electrical Specifications

Parameter	Conditions & Remarks	Min	Typical	Max	Unit	
Operating Conditions						
Operating Temperature Range	T _{OP}	-40	-	85	°C	
Supply Voltage	V _{CC}	3.14 4.75	3.3 5.0	3.46 5.25	Vdc	
Power Consumption	Warm-up Steady State; T _A = 25°C	- -	0.8 0.15	1.1 0.2	W	
Load	10 MHz 100 MHz		10 kΩ // 10pF 10 kΩ // 5pF			
Frequency Stability						
Frequency	F _{NOM}	8	-	120	MHz	
Freq. vs Temperature (See options - Table 1)	-30°C to 70°C	-	-	±5	ppb	
Freq. vs Supply Voltage	V _{CC} ±5%	-	±2	-	ppb	
Freq. vs Time (Aging)	After 30 days of operation	- -	±0.3 ±50	- -	ppb/day ppb/year	
G-Sensitivity (Note 1)	Worst direction	-	±1*	-	ppb/G	
Allan Variance	1 sec	-	0.02	-	ppb	
Warm-up time	@ 25°C, to within ±0.1 ppm referenced to the freq after 15 minutes on	-	60	90	sec	
Output Parameters						
HCMOS Output Levels	3.3V 5.0V	V _{OL}	- -	- -	0.4 0.4	Vdc
		V _{OH}	2.4 3.8	- -	- -	
Rise/Fall Times	10-90%	10 MHz 100 MHz	- -	- -	10 3	ns
Duty Cycle	@50% of output signal		45	50	55	%
Subharmonics			None			
Phase Noise (Note 2)		Offset	10 MHz (typical)	100 MHz (typical)		dBc/Hz
		1 Hz	-90	-		
		10 Hz	-120	-90		
		100 Hz	-140	-120		
		1 kHz	-160	-140		
		10 kHz	-165	-160		
	100 kHz	-165	-165			

* Note 1 – Lower G-Sensitivity performance is available. Consult factory.

** Note 2 – For additional phase noise options, consult factory.

Electrical Specifications (Continued)

Parameter	Conditions & Remarks	Min	Typical	Max	Unit	
Electronic Frequency Control - EFC						
EFC Control Voltage	V_C	5V	0.0	-	4.2	Volts
		3.3V	0.0	-	2.8	
Frequency Tuning Range		± 0.5	± 1	-	ppm	
Slope	Positive, monotonic	-	-	-		
Input Impedance	Z_{IN}	10	-	-	Kohms	
Linearity		-	-	10	%	
Reference Output	V_{REF}	5V	4.1	4.2	4.3	Volts
		3.3V	2.7	2.8	2.9	

Mechanical and Environmental

Storage Temperature Range	-60°C to +90°C
Humidity	Non-condensing 95%
Mechanical Shock	MIL-STD-202G, meth 213B, 30g, 11ms, 1/2 sine pulse - standard
	MIL-STD-202G, meth 213B, 500g, 1ms, 1/2 sine pulse – option (consult factory)
Vibration	MIL-STD-202G, meth 204D, 1.5mm DA 10 to 55Hz, 10G pk sine 55 to 2kHz - standard
	MIL-STD-202G, meth 204D, 1.5mm DA 10 to 100Hz, 30G pk sine to 2kHz – option
Soldering Conditions	Hand solder only – not reflow compatible. 260°C, 10 seconds.
Markings	Epoxy ink or laser engraved

Mechanical Specifications

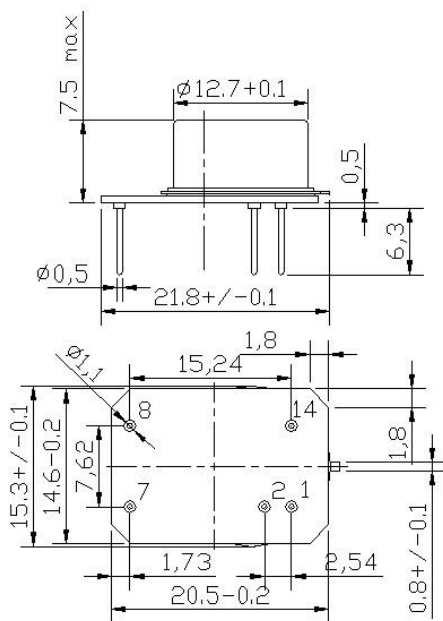

Pin	Connection
1	V_C
2	V_{REF}
7	Ground
8	Output
14	V_{CC}

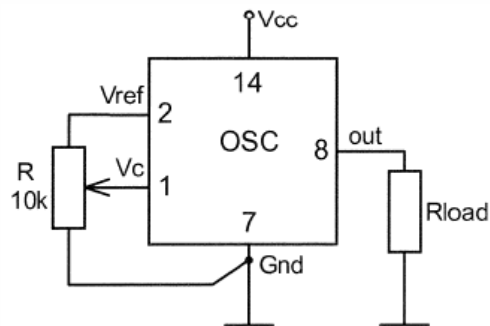

This product is specified for use only in standard commercial applications. Supplier disclaims all express and implied warranties and liability in connection with any use of this product in any non-commercial applications or in any application that may expose the product to conditions that are outside of the tolerances provided in its specification.