

DM93S41 4-Bit Arithmetic Logic Unit

General Description

The DM93S41 4-bit arithmetic logic units can perform all the possible 16 logic operations on two variables and a variety of

arithmetic operations; the Add and Subtract modes are the most important. The DM93S41 is a pin replacement for the 54/74181.

Connection Diagram

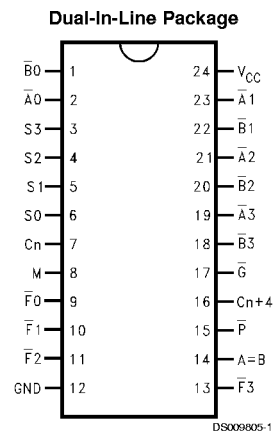

Order Number DM93S41N
See Package Number N24A

Pin Name	Description
$\bar{A}0$ – $\bar{A}3$, $\bar{B}0$ – $\bar{B}3$	Operand Inputs (Active LOW)
$S0$ – $S3$	Function Select Inputs
M	Mode Control Input
C_n	Carry Input
$\bar{F}0$ – $\bar{F}3$	Function Outputs (Active LOW)
A = B	Comparator Output
\bar{G}	Carry Generate Output (Active LOW)
\bar{P}	Carry Propagate Output (Active LOW)
C_{n+4}	Carry Output

Logic Symbols

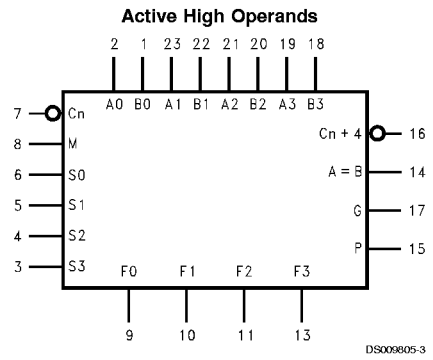
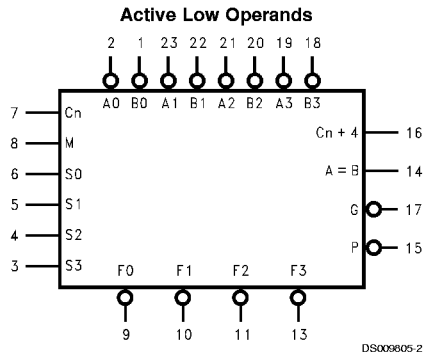

Absolute Maximum Ratings (Note 1)

Supply Voltage 7V
Input Voltage: 5.5V

Operating Free Air Temperature Range

DM93S 0°C to +70°C
Storage Temperature Range -65°C to +150°C

Recommended Operating Conditions

Symbol	Parameter	DM93S41			Units
		Min	Nom	Max	
V _{CC}	Supply Voltage	4.75	5	5.25	V
V _{IH}	High Level Input Voltage	2			V
V _{IL}	Low Level Input Voltage			0.8	V
I _{OH}	High Level Output Current			-1	mA
I _{OL}	Low Level Output Current			20	mA
T _A	Free Air Operating Temperature	0		70	°C

Note 1: The "Absolute Maximum Ratings" are those values beyond which the safety of the device cannot be guaranteed. The device should not be operated at these limits. The parametric values defined in the "Electrical Characteristics" table are not guaranteed at the absolute maximum ratings. The "Recommended Operating Conditions" table will define the conditions for actual device operation.

Electrical Characteristics

over recommended operating free air temperature range (unless otherwise noted)

Symbol	Parameter	Conditions	Min	Typ (Note 2)	Max	Units
V _I	Input Clamp Voltage	V _{CC} = Min, I _I = -18 mA			-1.2	V
V _{OH}	High Level Output Voltage	V _{CC} = Min, I _{OH} = Max V _{IL} = Max	2.7	3.4		V
V _{OL}	Low Level Output Voltage	V _{CC} = Min, I _{OL} = Max V _{IH} = Min		0.35	0.5	V
I _I	Input Current @ Max Input Voltage	V _{CC} = Max, V _I = 5.5V			1	mA
I _{IH}	High Level Input Current	V _{CC} = Max, V _I = 2.7V			50	μA
I _{IL}	Low Level Input Current	V _{CC} = Max, V _I = 0.5V			-1.6	mA
I _{OS}	Short Circuit Output Current	V _{CC} = Max (Note 3)	-40		-100	mA
I _{CCL}	Supply Current	V _{CC} = Max M, S0-S3 = 4.5V All Other Inputs = 0V			150	mA
I _{CCH}	Supply Current	V _{CC} = Max C _n , B0-B3 = GND All Other Inputs = 4.5V			140	mA

Note 2: All typicals are at V_{CC} = 5V, T_A = 25°C.

Note 3: Not more than one output should be shorted at a time, and the duration should not exceed one second.

Switching Characteristics

$V_{CC} = +5.0V$, $T_A = +25^\circ C$ (See Section 1 for waveforms and load configurations)

Symbol	Parameter	Conditions	CL = 15 pF R _L = 280Ω		Units
			Min	Max	
t _{PLH} t _{PHL}	Propagation Delay C _n to C _{n+4}	M = Gnd		12	ns
t _{PLH} t _{PHL}	Propagation Delay C _n to \bar{F}	M = Gnd		12	ns
t _{PLH} t _{PHL}	Propagation Delay \bar{A}_n or \bar{B}_n to \bar{G}	M, S1, S2 = Gnd S0, S3 = 4.5V		14	ns
t _{PLH} t _{PHL}	Propagation Delay \bar{A}_n or \bar{B}_n to \bar{G}	M, S0, S3 = Gnd S1, S2 = 4.5V		15	ns
t _{PLH} t _{PHL}	Propagation Delay \bar{A}_n or \bar{B}_n to \bar{P}	M, S1, S2 = Gnd S0, S3 = 4.5V		14	ns
t _{PLH} t _{PHL}	Propagation Delay \bar{A}_n or \bar{B}_n to \bar{P}	M, S0, S3 = Gnd S1, S2 = 4.5V		15	ns
t _{PLH} t _{PHL}	Propagation Delay \bar{A}_i or \bar{B}_i to \bar{F}_i	M, S1, S3 = Gnd S0, S3 = 4.5V		20	ns
t _{PLH} t _{PHL}	Propagation Delay \bar{A}_i or \bar{B}_i to \bar{F}_i	M, S0, S3 = Gnd S1, S2 = 4.5V		21	ns
t _{PLH} t _{PHL}	Propagation Delay \bar{A}_i or \bar{B}_i to \bar{F}_{i+1}	M, S1, S2 = Gnd S0, S3 = 4.5V		24	ns
t _{PLH} t _{PHL}	Propagation Delay \bar{A}_i or \bar{B}_i to \bar{F}_{i+1}	M, S0, S3 = Gnd S1, S2 = 4.5V		25	ns
t _{PLH} t _{PHL}	Propagation Delay \bar{A}_n or \bar{B}_n to \bar{F}	M = 4.5V		20	ns
t _{PLH} t _{PHL}	Propagation Delay \bar{A}_n or \bar{B}_n to C _{n+1}	M, S1, S2 = Gnd S0, S3 = 4.5V		18.5	ns
t _{PLH} t _{PHL}	Propagation Delay \bar{A}_n or \bar{B}_n to C _{n+1}	M, S0, S3 = Gnd S1, S2 = 4.5V		23	ns
t _{PLH} t _{PHL}	Propagation Delay \bar{A}_n or \bar{B}_n to A = B	M, S0, S3 = Gnd S1, S2 = 4.5V R _L = 400Ω to 5.0V		23	ns

Functional Description

The DM93S41 is a 4-bit high speed parallel arithmetic logic unit (ALU). Controlled by the four Function Select inputs (S0–S3) and the Mode Control input (M), it can perform all the 16 possible operations or 16 different arithmetic operations on active HIGH or active LOW operands. The Function Table below lists these operations.

When the Mode Control input (M) is HIGH, all internal carries are inhibited and the device performs logic operations on the individual bits as listed. When the Mode Control input is LOW, the carries are enabled and the device performs arithmetic operations on the two 4-bit words. The device incorporates full internal carry lookahead and provides for either ripple carry between devices using the C_{n+4} output, or for carry lookahead between packages using the signals \bar{P} (Carry Propagate) and \bar{G} (Carry Generate). \bar{P} and \bar{G} are not affected by carry in. When speed requirements are not stringent, the DM93S41 can be used in a simple ripple carry mode by connecting the Carry output (C_{n+4}) signal to the

Carry input (C_n) of the next unit. For super high speed operation the Schottky DM93S41 should be used in conjunction with the '42 carry lookahead circuit.

The A = B output from the DM93S41 goes HIGH when all four \bar{F}_n outputs are HIGH and can be used to indicate logic equivalence over four bits when the unit is in the subtract mode. The A = B output is open-collector and can be wired-AND with the other A = B outputs to give a comparison for more than four bits. The A = B signal can also be used with the C_{n+4} signal to indicate A > B and A < B.

The Function Table lists the arithmetic operations that are performed without a carry in. An incoming carry adds a one to each operation. Thus select code LHHH generates A minus B minus 1 (2s complement notation) without a carry in and generates A minus B when a carry is applied. Because subtraction is actually performed by complementary addition (1s complement), a carry out means borrow; thus a carry is generated when there is no underflow and no carry is generated when there is underflow.

Functional Description (Continued)

As indicated the '41 can be used with either active LOW inputs producing active LOW outputs or with active HIGH in-

puts producing active HIGH outputs. For either case the table lists the operations that are performed to the operands labeled inside the logic symbol.

Function Table

Mode Select Inputs				Active Low Inputs & Outputs		Active High Inputs & Outputs	
S3	S2	S1	S0	Logic Arithmetic (Note 5)		Logic Arithmetic (Note 5)	
				(M = H)	(M = L) (C _n = L)	(M = H)	(M = L) (C _n = H)
L	L	L	L	\bar{A}	A minus 1	\bar{A}	A
L	L	L	H	\overline{AB}	AB minus 1	$\bar{A} + \bar{B}$	A + B
L	L	H	L	$\bar{A} + \bar{B}$	\overline{AB} minus 1	\overline{AB}	A + \bar{B}
L	L	H	H	Logic 1	minus 1	Logic 0	minus 1
L	H	L	L	$\bar{A} + \bar{B}$	A plus (A + \bar{B})	\overline{AB}	A plus \overline{AB}
L	H	L	H	\bar{B}	AB plus (A + \bar{B})	\bar{B}	(A + B) plus \overline{AB}
L	H	H	L	$\bar{A} \oplus \bar{B}$	A minus B minus 1	A \oplus B	A minus B minus 1
L	H	H	H	A + \bar{B}	A + \bar{B}	\overline{AB}	\overline{AB} minus 1
H	L	L	L	\overline{AB}	A plus (A + B)	$\bar{A} + B$	A plus AB
H	L	L	H	A \oplus B	A plus B	A \oplus B	A plus B
H	L	H	L	B	\overline{AB} plus (A + B)	B	(A + \bar{B}) plus AB
H	L	H	H	A + B	A + B	AB	AB minus 1
H	H	L	L	Logic 0	A plus A (Note 4)	Logic 1	A plus A (Note 4)
H	H	L	H	\overline{AB}	AB plus A	A + \bar{B}	(A + B) plus A
H	H	H	L	AB	\overline{AB} minus A	A + B	(A + \bar{B}) plus A
H	H	H	H	A	A	A	A minus 1

H = HIGH Voltage Level

L = LOW Voltage Level

Note 4: Each bit is shifted to the next more significant position

Note 5: Arithmetic operations expressed in 2s complement notation

Logic Diagram

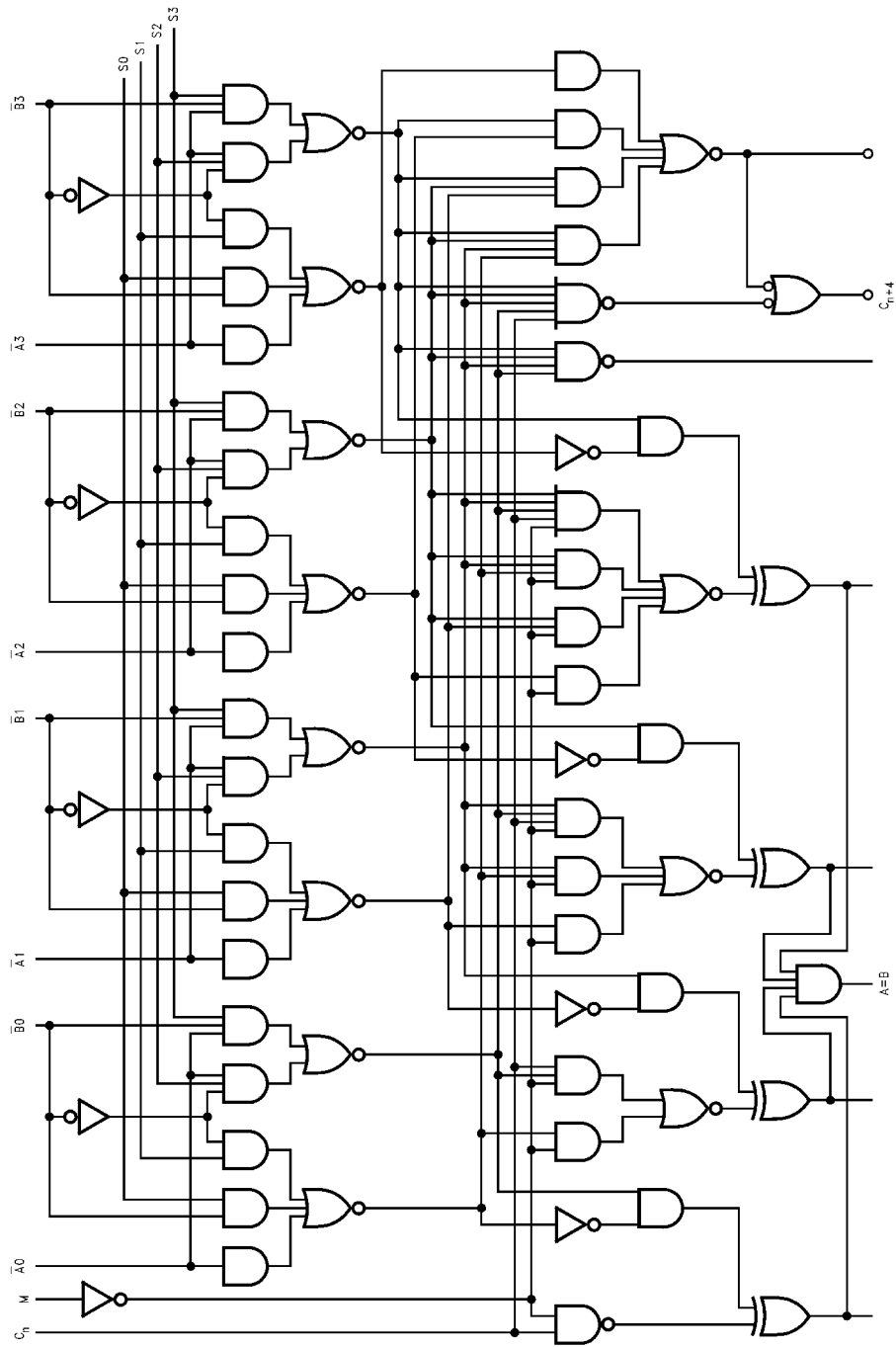

DS90C035-4

Logic Diagram (Continued)

TABLE 1. SUM MODE TEST Function Inputs: S0 = S3 = 4.5V, S1 = S2 = M = 0V

Symbol	Input Under Test	Other Input Same Bit		Other Data Input		Output Under Test
		Apply 4.5V	Apply GND	Apply 4.5V	Apply GND	
t_{PLH} t_{PHL}	\bar{A}_i	\bar{B}_i	None	Remaining \bar{A} to \bar{B}	C_n	\bar{F}_i
t_{PLH} t_{PHL}	\bar{B}_i	\bar{A}_i	None	Remaining \bar{A} to \bar{B}	C_n	\bar{F}_i
t_{PLH} t_{PHL}	\bar{A}_i	\bar{B}_i	None	C_n	Remaining \bar{A} and \bar{B}	\bar{F}_{i+1}
t_{PLH} t_{PHL}	\bar{B}_i	\bar{A}_i	None	C_n	Remaining \bar{A} and \bar{B}	\bar{F}_{i+1}
t_{PLH} t_{PHL}	\bar{A}	\bar{B}	None	None	Remaining \bar{A} and \bar{B} , C_n	\bar{P}
t_{PLH} t_{PHL}	\bar{B}	\bar{A}	None	None	Remaining \bar{A} and \bar{B} , C_n	\bar{P}
t_{PLH} t_{PHL}	\bar{A}	None	\bar{B}	Remaining \bar{B}	Remaining \bar{A} , C_n	\bar{G}
t_{PLH} t_{PHL}	\bar{B}	None	\bar{A}	Remaining \bar{B}	Remaining \bar{A} , C_n	\bar{G}
t_{PLH} t_{PHL}	\bar{A}	None	\bar{B}	Remaining \bar{B}	Remaining \bar{A} , C_n	C_{n+4}
t_{PLH} t_{PHL}	\bar{B}	None	\bar{A}	Remaining \bar{B}	Remaining \bar{A} , C_n	C_{n+4}
t_{PLH} t_{PHL}	C_n	None	None	All \bar{A}	All \bar{B}	Any \bar{F} or C_{n+4}

TABLE 2. DIFF MODE TEST Function Inputs: S1 = S2 = 4.5V, S0 = S3 = M = 0V

Symbol	Input Under Test	Other Input Same Bit		Other Data Inputs		Output Under Test
		Apply 4.5V	Apply GND	Apply 4.5V	Apply GND	
t_{PLH} t_{PHL}	\bar{A}	None	\bar{B}	Remaining \bar{A}	Remaining \bar{B} , C_n	\bar{F}_i
t_{PLH} t_{PHL}	\bar{B}	\bar{A}	None	Remaining \bar{A}	Remaining \bar{B} , C_n	\bar{F}_i
t_{PLH} t_{PHL}	\bar{A}_i	None	\bar{B}_i	Remaining \bar{B} , C_n	Remaining \bar{A}	\bar{F}_{i+1}
t_{PLH} t_{PHL}	\bar{B}_i	\bar{A}_i	None	Remaining \bar{B} , C_n	Remaining \bar{A}	\bar{F}_{i+1}
t_{PLH} t_{PHL}	\bar{A}	None	\bar{B}	None	Remaining \bar{A} and \bar{B} , C_n	\bar{P}
t_{PLH} t_{PHL}	\bar{B}	\bar{A}	None	None	Remaining \bar{A} and \bar{B} , C_n	\bar{P}
t_{PLH} t_{PHL}	\bar{A}	\bar{B}	None	None	Remaining \bar{A} and \bar{B} , C_n	\bar{G}

Logic Diagram (Continued)

TABLE 2. DIFF MODE TEST Function Inputs: S1 = S2 = 4.5V, S0 = S3 = M = 0V (Continued)

Symbol	Input Under Test	Other Input Same Bit		Other Data Inputs		Output Under Test
		Apply 4.5V	Apply GND	Apply 4.5V	Apply GND	
t_{PLH} t_{PHL}	\bar{B}	None	\bar{A}	None	Remaining \bar{A} and \bar{B} , C_n	\bar{G}
t_{PLH} t_{PHL}	\bar{A}	None	\bar{B}	Remaining \bar{A}	Remaining \bar{B} , C_n	A = B
t_{PLH} t_{PHL}	\bar{B}	\bar{A}	None	Remaining \bar{A}	Remaining \bar{B} , C_n	A = B
t_{PLH} t_{PHL}	\bar{A}	\bar{B}	None	None	Remaining \bar{A} and \bar{B} , C_n	$C_n + 4$
t_{PLH} t_{PHL}	\bar{B}	None	\bar{A}	None	Remaining \bar{A} and \bar{B} , C_n	$C_n + 4$
t_{PLH} t_{PHL}	C_n	None	None	All \bar{A} and \bar{B}	None	$C_n + 4$

TABLE 3. LOGIC MODE TEST Function Inputs: S1 = S2 = M = 4.5V, S0 = S3 = 0V

Symbol	Input Under Test	Other Input Same Bit		Other Data Inputs		Output Under Test
		Apply 4.5V	Apply GND	Apply 4.5V	Apply GND	
t_{PLH} t_{PHL}	\bar{A}	\bar{B}	None	None	Remaining \bar{A} and \bar{B} , C_n	Any \bar{F}
t_{PLH} t_{PHL}	\bar{B}	\bar{A}	None	None	Remaining \bar{A} and \bar{B} , C_n	Any \bar{F}

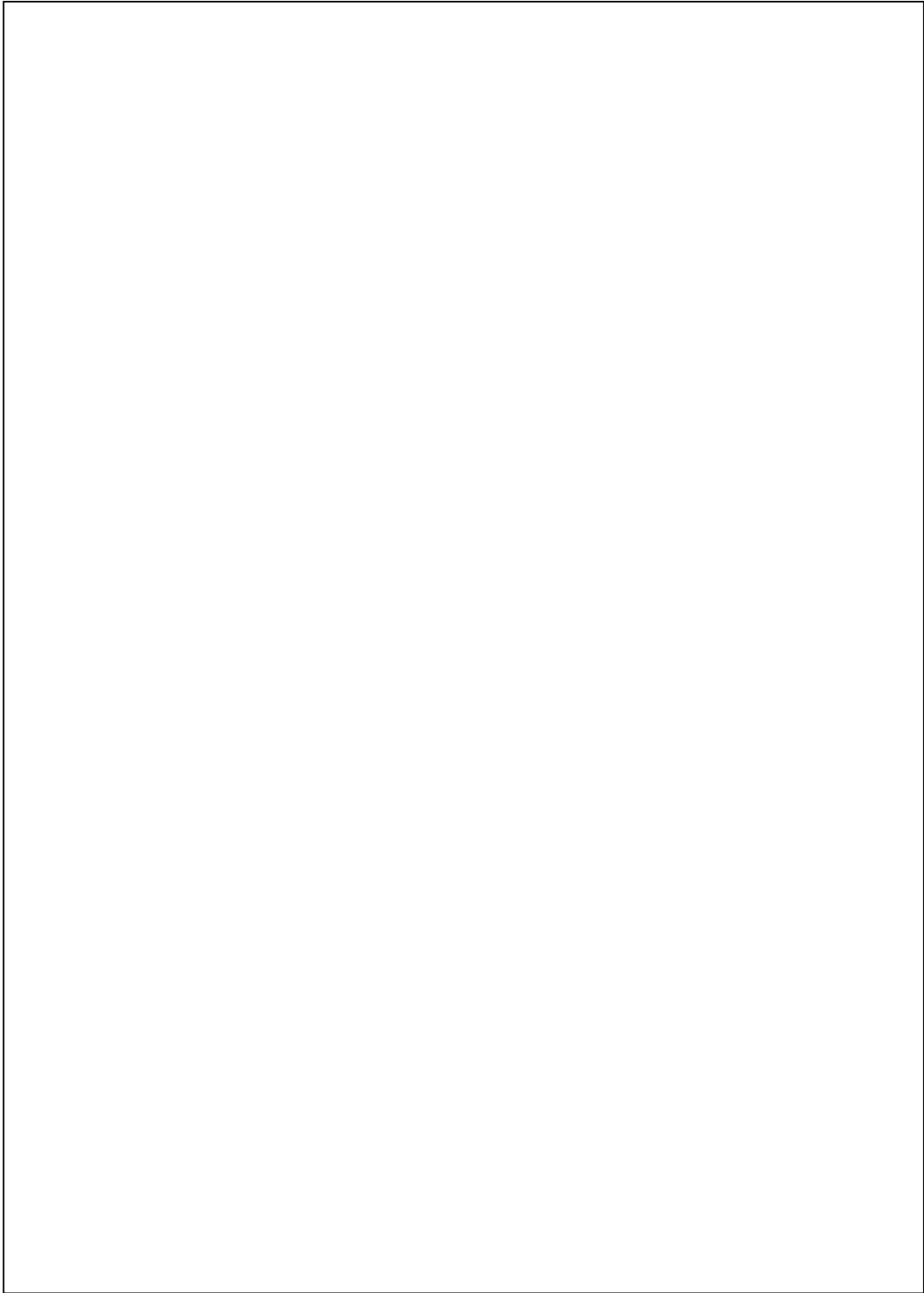

Physical Dimensions inches (millimeters) unless otherwise noted

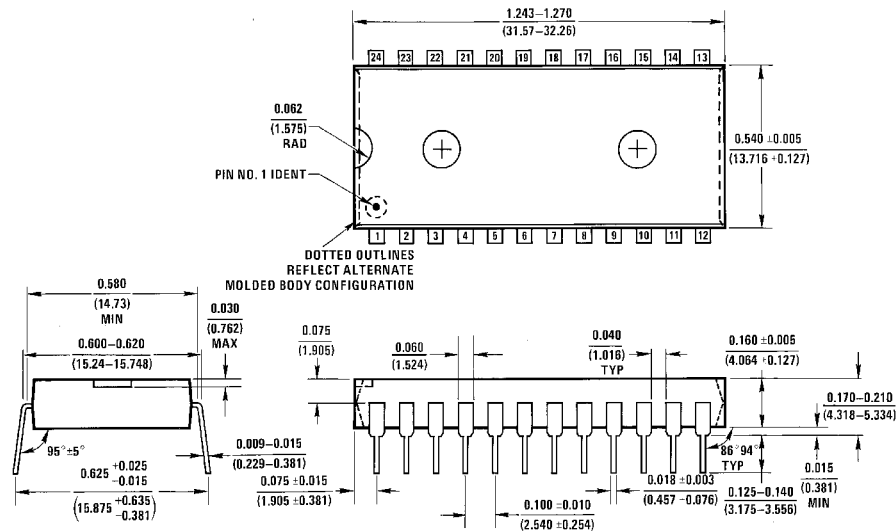

24-Lead Molded Dual-In-Line Package (N)
Order Number DM93S41N
Package Number N24A

N24A (REV E)

LIFE SUPPORT POLICY

FAIRCHILD'S PRODUCTS ARE NOT AUTHORIZED FOR USE AS CRITICAL COMPONENTS IN LIFE SUPPORT DEVICES OR SYSTEMS WITHOUT THE EXPRESS WRITTEN APPROVAL OF THE PRESIDENT OF FAIRCHILD SEMICONDUCTOR CORPORATION. As used herein:

1. Life support devices or systems are devices or systems which, (a) are intended for surgical implant into the body, or (b) support or sustain life, and (c) whose failure to perform when properly used in accordance with instructions for use provided in the labeling, can be reasonably expected to result in a significant injury to the user.
2. A critical component in any component of a life support device or system whose failure to perform can be reasonably expected to cause the failure of the life support device or system, or to affect its safety or effectiveness.

Fairchild Semiconductor Corporation
 Americas
 Customer Response Center
 Tel: 1-888-522-5372

Fairchild Semiconductor Europe
 Fax: +49 (0) 1 80-530 85 86
 Email: europe.support@nsc.com
 Deutsch Tel: +49 (0) 8 141-35-0
 English Tel: +44 (0) 1 793-85-68-56
 Italy Tel: +39 (0) 2 57 5631

Fairchild Semiconductor Hong Kong Ltd.
 13th Floor, Straight Block,
 Ocean Centre, 5 Canton Rd.
 Tsimshatsui, Kowloon
 Hong Kong
 Tel: +852 2737-7200
 Fax: +852 2314-0061

National Semiconductor Japan Ltd.
 Tel: 81-3-5620-6175
 Fax: 81-3-5620-6179

www.fairchildsemi.com