

TRIPLE DIFFUSED PLANER TYPE
HIGH POWER DARLINGTON
INDUSTRIAL USE POWER SUPPLY

Features

- High D.C. current gain
- Excellent linearity in h_{FE}
- Excellent safe operating area
- High reliability

Applications

- Color & B/W TV power supply
- Active power filter
- Industrial use power supply (Series regulator)
- General purpose power amplifiers

Outline Drawings

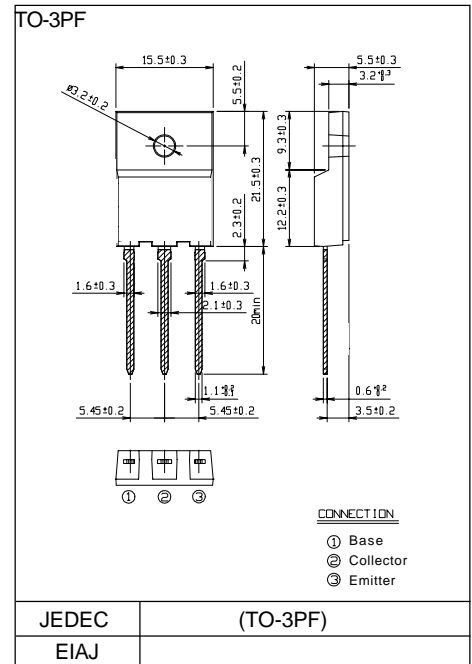

Equivalent Circuit Schematic

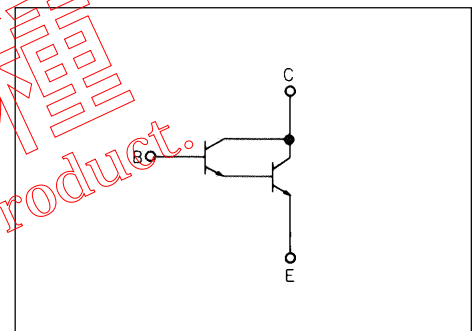

Maximum ratings and characteristic

● Absolute maximum ratings ($T_c=25^\circ\text{C}$ unless otherwise specified)

Item	Symbol	Rating	Unit
Collector-Base voltage	V_{CB0}	150	V
Collector-Emitter voltage	V_{CE0}	100	V
Emitter-Base voltage	V_{EB0}	6	V
Collector current	I_C	10	A
Base current	I_B	1	A
Collector power dissipation	P_C	80	W
Operating junction temperature	T_j	+150	$^\circ\text{C}$
Storage temperature	T_{stg}	-55 to +150	$^\circ\text{C}$

● Electrical characteristics ($T_c = 25^\circ\text{C}$ unless otherwise specified)

Item	Symbol	Test Conditions	Min.	Typ.	Max.	Units
Collector-Base voltage	V_{CB0}	$I_{CBO} = 1\text{mA}$	150			V
Collector-Emitter voltage	$V_{CE0(SUS)}$	$I_{CEO} = 10\text{mA}$	100			V
Emitter-Base voltage	V_{EB0}	$I_{EBO} = 1\text{mA}$	6			V
Collector-Base leakage current	I_{CBO}	$V_{CB0} = 150\text{V}$			1.0	mA
Emitter-Base leakage current	I_{EBO}	$V_{CB0} = 6\text{V}$			1.0	mA
D.C. current gain	h_{FE}	$I_C = 3\text{A}, V_{CE} = 4\text{V}$	700			
Collector-Emitter saturation voltage	$V_{CE(Sat)}$	$I_C = 1.5\text{A}, I_B = 50\text{mA}$			1.5	V
Base-Emitter saturation voltage	$V_{BE(Sat)}$				2.0	V

Thermal characteristics

Item	Symbol	Test Conditions	Min.	Typ.	Max.	Units
Thermal resistance	$R_{th(j-c)}$	Junction to case			1.55	$^\circ\text{C/W}$

Characteristics

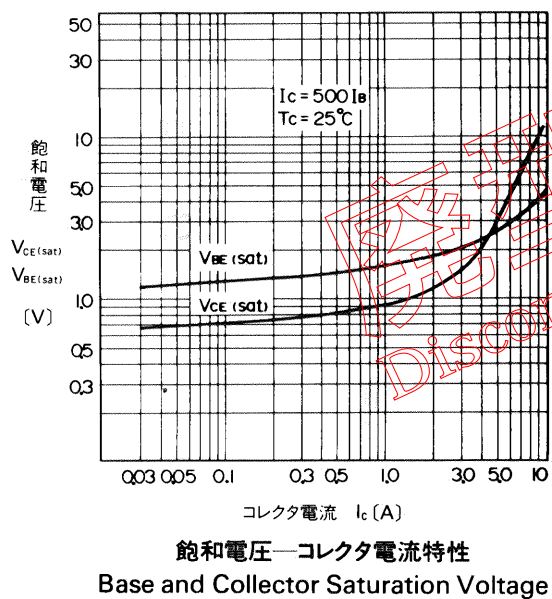
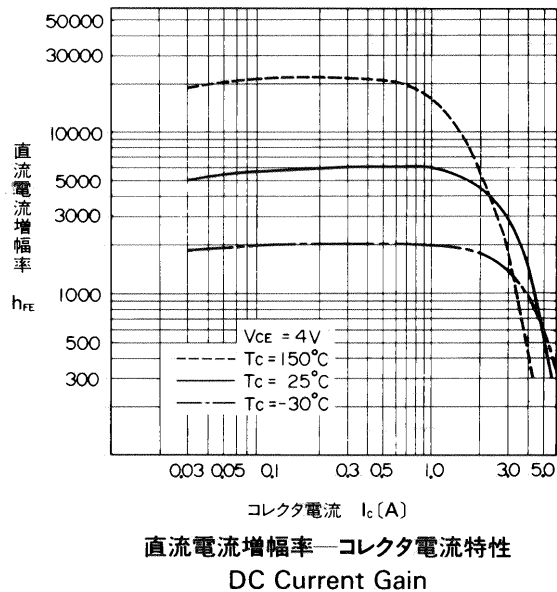
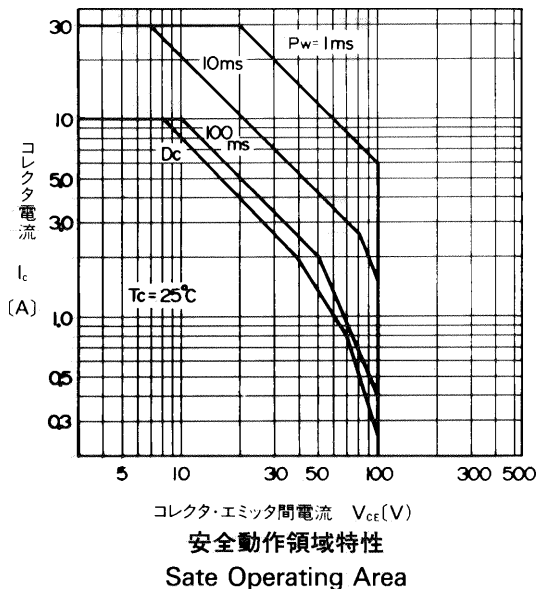

廃止機種
 Discontinued product.