

PRELIMINARY

TQ9223

3 V RFIC Downconverter

ICs

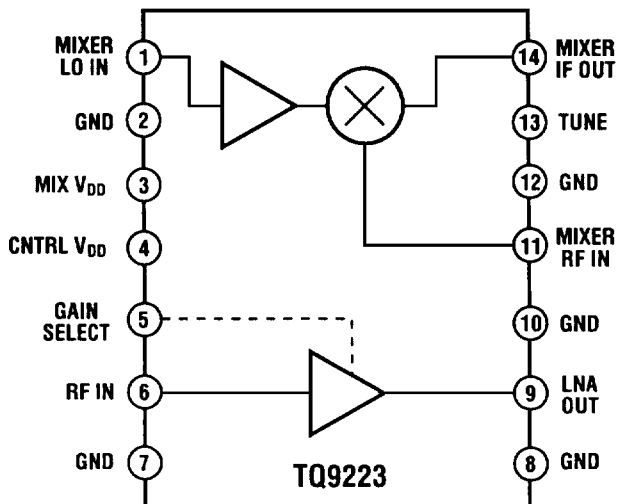

The TQ9223 RFIC Downconverter is a multifunction RF front end designed for the high dynamic range cellular communications standards. The design of the TQ9223 provides a 2.5 dB system noise figure for excellent sensitivity, and a good signal range with -10 dBm input IP3. Its low current consumption, single +3 V operation and small, plastic surface-mount package are ideally suited for cost-competitive, space-limited and portable applications. The TQ9223 is specified over an RF frequency range of 800 to 1000 MHz, and therefore may be used for any of the cellular and cordless telephony standards.

Electrical Specifications

Test Conditions: $V_{DD} = 3.0\text{ V}$, $T_A = 25^\circ\text{C}$, Filter IL = 3 dB

Downconverter	Min.	Typ.	Max.	Units
Conversion Gain		20		dB
Noise Figure ⁽¹⁾		2.5		dB
Input 3rd Order Intercept ⁽²⁾		-11		dBm
Supply Voltage	2.7	3.3	5.5	V
Supply Current		10		mA

Notes: 1. Specified with external noise-matching circuit elements, with image-stripping BPF.
2. Frequency separation of the two signals is 500 KHz.

Features

- + 3 V single supply
- On-chip LO buffer
- Mixer LO and RF matched to 50 Ω
- Low-cost SO-14 plastic package
- Gain Select (high/low)

Applications

- Analog Cellular Phones
- Digital Cellular Phones
- Cordless Telephones
- CDPD terminals

Electrical Specifications – Downconverter

Test Conditions: $V_{DD} = 3.0V$, $T_A = 25^\circ C$, Filter IL = 3 dB, RF = 881 MHz, LO = 966 MHz, IF = 85 MHz

Parameter	Conditions	Min	Typ	Max	Units
RF Frequency Range	Tuned external match	800		1000	MHz
LO Frequency Range		500		1300	MHz
IF Frequency Range		45		300	MHz

Parameter	Conditions	Min	Typ	Max	Units
Conversion Gain			20		dB
Noise Figure			2.5		dB
Input 3rd Order Intercept			-11		dBm
MIXER RF Return Loss			10		dB
MIXER LO Return Loss			10		dB
LO Input Power			-6		dB
Mixer LO to IF Isolation	After external match		40		dB
LO to RF Input Isolation			30		dB
Supply Voltage		2.7	3.0	5.5	V
Supply Current			10		mA

Notes: 1. Conversion gain, noise figure, and IP3 assume an image stripping band-pass filter between the LNA section and the Mixer section with a 3 dB insertion loss.
 2. With optimum noise match, which results in approximately 12 dB return loss at the input port. $G_{OPT} \cdot |G| = 0.7$, $\angle G = 31^\circ$.

Test Circuit

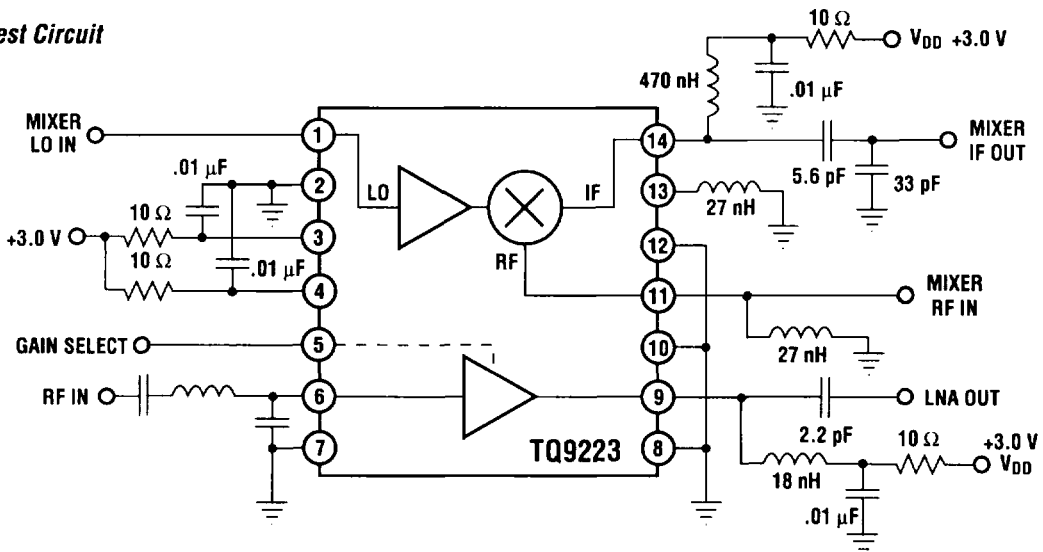

Electrical Specifications – LNA Section

Test Conditions: $V_{DD} = 3.0V$, $T_A = 25^\circ C$, Frequency = 881 MHz

LNA	Conditions	Min.	Typ.	Max.	Units
Gain			17		dB
Noise Figure			1.8		dB
Output 3rd Order Intercept			+13		dBm
Output 1 dB Gain Compression			4		dBm
Reverse Isolation			25		dB
Supply Voltage		2.7	3.0	5.5	V
Supply Current			6		mA

Electrical Specifications – Mixer Section

Test Conditions: $V_{DD} = 3.0V$, $T_A = 25^\circ C$, Filter IL = 3 dB, RF = 881 MHz, LO = 966 MHz, IF = 85 MHz

Mixer	Conditions	Min.	Typ.	Max.	Units
Conversion Gain			5		dB
Noise Figure			8		dB
Output 3rd Order Intercept			10		dBm
Mixer RF Return Loss			10		dB
Mixer LO Return Loss			10		dB
LO Input Power			-6		dBm
LO to IF Isolation			40		dB
LO to RF Isolation			5		dB
RF to IF Isolation			40		dB
Supply Voltage		2.7	3.0	5.5	V
Supply Current			4		mA



Pin Descriptions

<i>Pin Name</i>	<i>Pin #</i>	<i>Description</i>
MIXER LO IN	1	Mixer LO input. Matched to 50 Ω. Internally DC blocked.
MIXER VDD	3	Mixer LO buffer V _{DD} . Bypass cap required.
CNRTL VDD	4	LNA gain select control V _{DD} . Bypass cap required.
GAIN SELECT	5	LNA gain select line. Logic HIGH = high gain, logic LOW = low gain.
RF IN	6	LNA RF Input port. Noise matching required. External DC blocking required.
LNA OUT	9	LNA Output port. Open drain output requires connection to V _{DD} and impedance matching to 50 Ω.
MIXER RF IN	11	Mixer RF Input port. Matched to 50 Ω. Internally DC blocked.
TUNE	13	LO buffer tuning, inductor to ground.
MIXER IF OUT	14	Mixer IF signal port. Open drain output requires connection to V _{DD} and impedance matching to load.
GND	2, 7, 8, 10, 12	Ground connection. Keep physically short for stability and performance. Use several via holes immediately adjacent to the pins down to backside ground plane.

Note: Refer to block diagram for pin location

TQ9223 Pinout

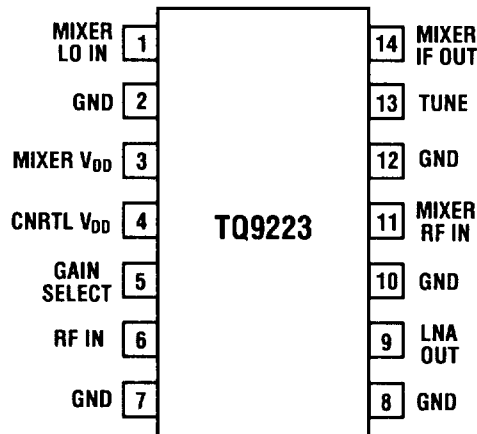

Absolute Maximum Ratings

Parameter	Min.	Typ.	Max.	Units
DC Power Supply			8.0	V
RF Input Power			TBD	dBm
Storage Temperature	-55		+150	°C
Operating Temperature	-40		+85	°C

ESD-sensitive device - Class 1

SO-14 Plastic Package

(J Suffix)

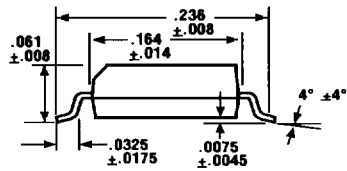
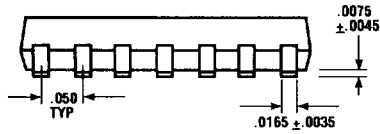
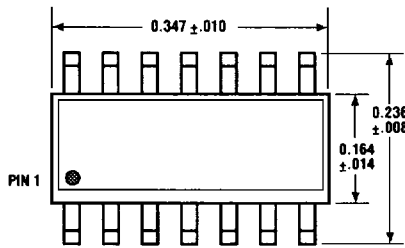

ICs

The information provided herein is believed to be reliable. TriQuint assumes no responsibility for inaccuracies or omissions. TriQuint assumes no responsibility for the use of this information, and all such information shall be entirely at the user's own risk. Prices and specifications are subject to change without notice. No patent rights or licenses to any of the circuits described herein are implied or granted to any third party. TriQuint does not authorize or warrant any TriQuint product for use in life-support devices and/or systems.

Copyright © 1995 TriQuint Semiconductor, Inc. All rights reserved.

Revision D.1, June 23, 1995

TriQuint 
SEMICONDUCTOR