



Dear customers,

**About the change in the name such as "Oki Electric Industry Co. Ltd." and "OKI" in documents to OKI Semiconductor Co., Ltd.**

The semiconductor business of Oki Electric Industry Co., Ltd. was succeeded to OKI Semiconductor Co., Ltd. on October 1, 2008. Therefore, please accept that although the terms and marks of "Oki Electric Industry Co., Ltd.", "Oki Electric", and "OKI" remain in the documents, they all have been changed to "OKI Semiconductor Co., Ltd.". It is a change of the company name, the company trademark, and the logo, etc. , and NOT a content change in documents.

October 1, 2008  
OKI Semiconductor Co., Ltd.

**OKI SEMICONDUCTOR CO., LTD.**

550-1 Higashiasakawa-cho, Hachioji-shi, Tokyo 193-8550, Japan  
<http://www.okisemi.com/en/>

---

**ML2302****Recording and Playback LSI with Built-in 2-Bit ADPCM2 Supported FIFO****GENERAL DESCRIPTION**

The ML2302 is a recording and playback LSI with built-in FIFO memories for buffering. It employs the new 2-bit ADPCM2 algorithm in addition to conventional 4-bit OKIADPCM and 4-bit OKIADPCM2 algorithms. The ML2302 operates at 2.7 to 3.6 V and supports a variety of applications.

**FEATURES**

- Built-in two 1024-bit FIFOs  
(buffering time of 32 ms when using 8 kHz sampling frequency and 4-bit ADPCM)
- Supports five compression algorithms for recording and playback:  
2-bit OKIADPCM2; 4/5/6/7-bit OKIADPCM2; 4-bit OKIADPCM; 8/16-bit straight PCM; 8-bit OKI Nonlinear PCM
- Source oscillation frequency 16.384 MHz
- Sampling frequency (fsam)
  - 4.0 to 12.8 kHz (OKIADPCM2)
  - 4.0 to 25.6 kHz (8-bit straight PCM)
- Supports 8-bit bus interface.
- Built-in voice level detection function (VAC)
- Built-in noise injection function
- Supports external DAC interface.
- Built-in volume control circuit
  - (0 dB to -44 dB: -2 dB step, -44 dB to -80 dB: -4 dB step)
- Built-in 14-bit A/D converter and 14-bit D/A converter
- Built-in low pass filter (LPF)  
(recording side: analog filter, playback side: digital filter)
- Built-in speaker amplifier (100 mW, 8Ω)
- Power supply voltage : +2.7 to +3.6 V
- Package : 64-pin plastic TQFP (TQFP64-P-1010-0.50-K) (ML2302TB)  
: 71-pin W – CSP

**BLOCK DIAGRAM**

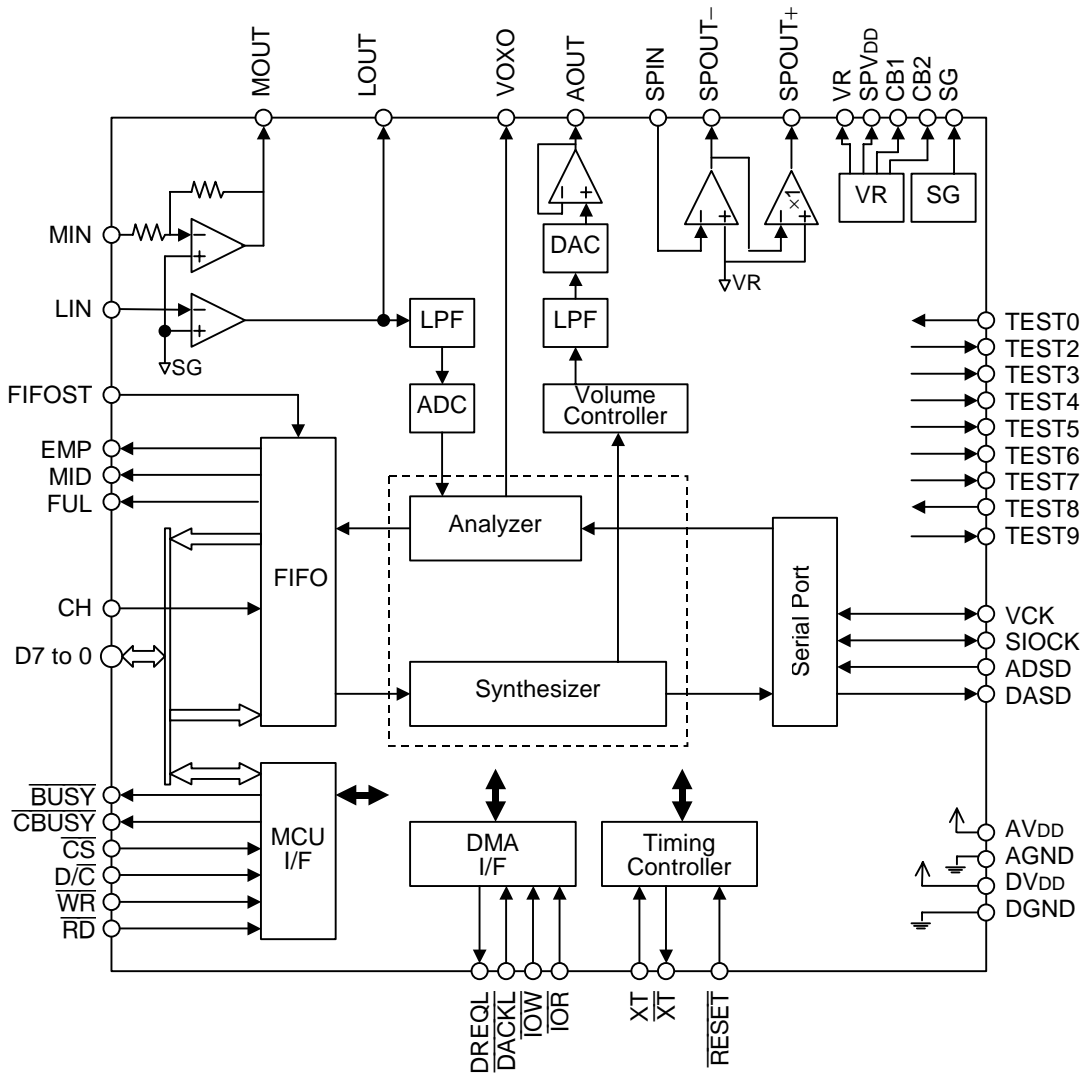

**PIN CONFIGURATION (TOP VIEW)**

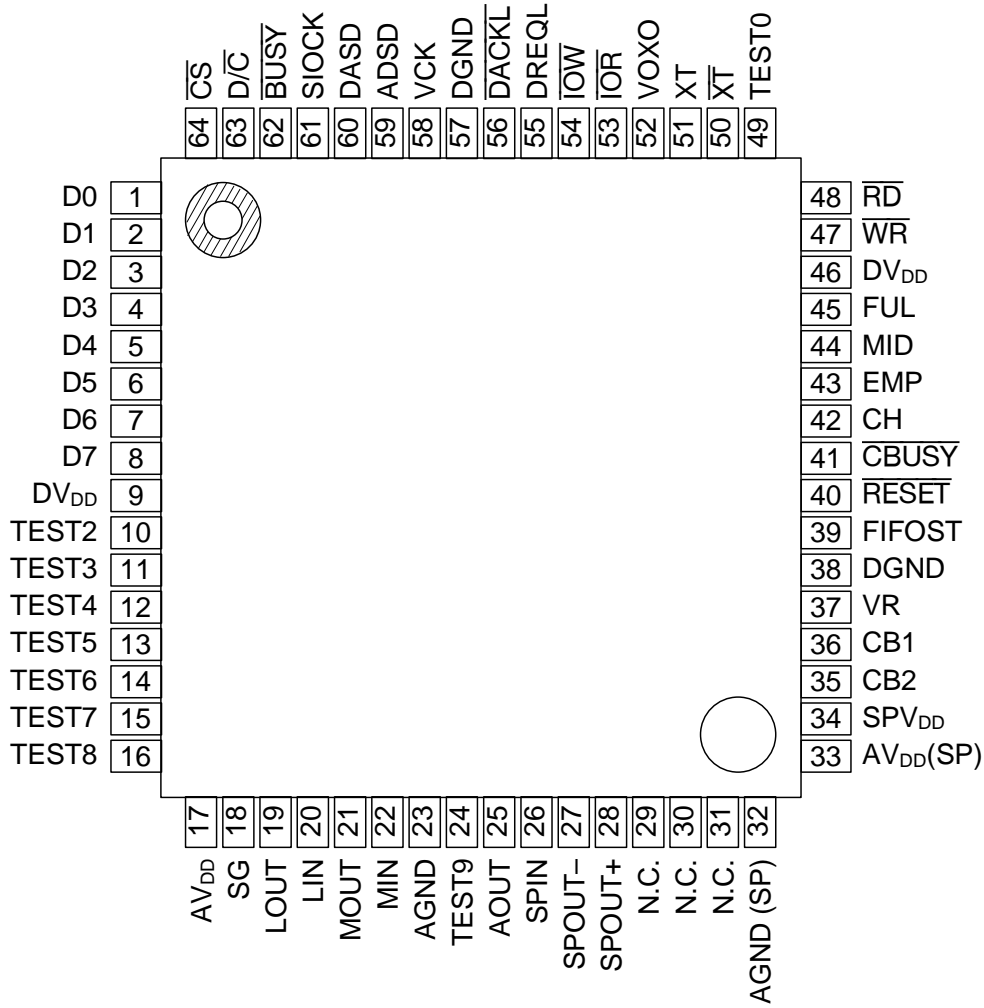

**N.C.: No Connection  
64-pin plastic TQFP**

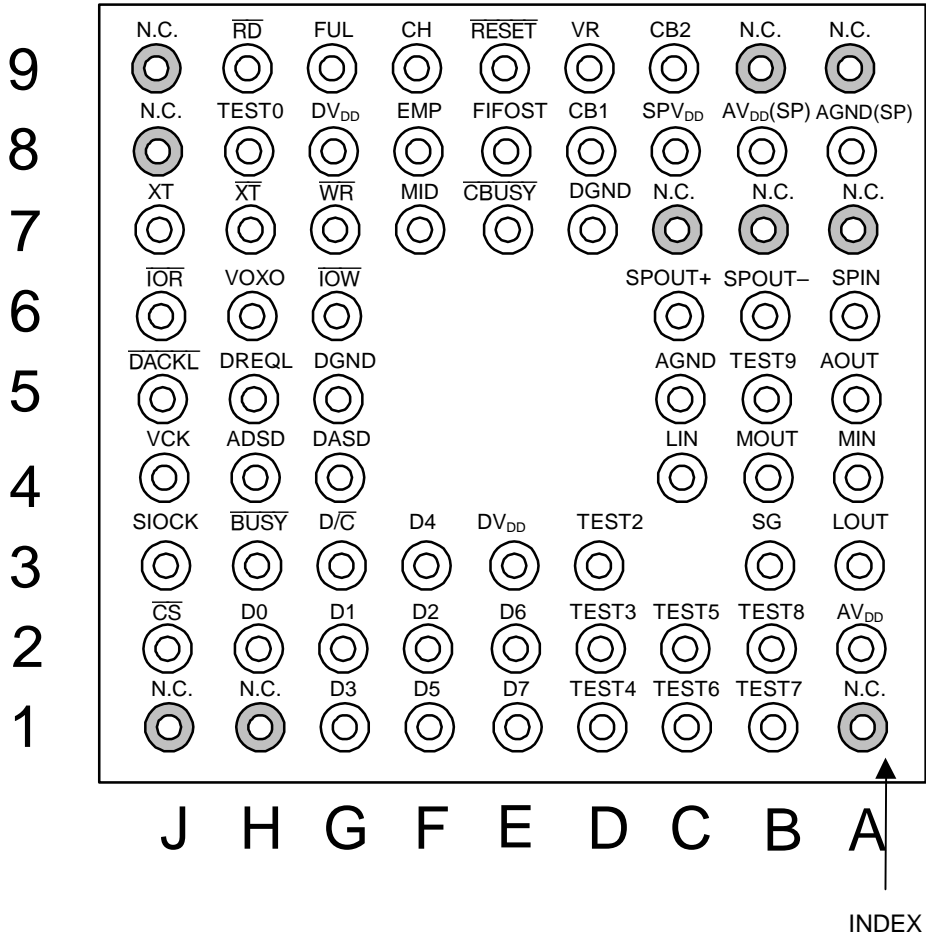

71-pin W-CSP (Bottom View)

## PIN DESCRIPTIONS

Pin (WCSP)	Pin (TQFP)	Symbol	Type	Description
H2, G2, F2, G1, F3, F1, E2, E1	1 to 8	D7 to 0	I/O	Bidirectional data bus. Command and data inputs from an external microcontroller and memory, and status and data outputs to an external microcontroller and memory.
G7	47	$\overline{WR}$	I	Write pulse input pin. This pin pulses "L" when command or voice data is input to D7 to D0 pins.
H9	48	$\overline{RD}$	I	Read pulse input pin. This pin pulses "L" when status or voice data is output to D7 to D0.
J2	64	$\overline{CS}$	I	Accepts write pulse and read pulse when this pin is "L".
G3	63	$D/\overline{C}$	I	Voice data is input or output to and from D7 to D0 when this pin is "H".
H3	62	$\overline{BUSY}$	O	This pin outputs a "L" level during RECORDING, PLAYBACK, or PAUSE.
E7	41	$\overline{CBUSY}$	O	Accepts a command during this pin is "H".
F8	43	EMP	O	"H" indicates that there is no data in FIFO memory. During playback, voice synthesis starts when EMP changes to "L". Active "H" can be changed to active "L".
F7	44	MID	O	"H" level indicates that there is more than half of the FIFO memory.
G9	45	FUL	O	"H" level indicates that FIFO memory is full of data. During playback, this pin is "H" and data cannot be written in FIFO memory. During recording, data is not written after FIFO memory is full of data. Active "H" can be changed to active "L".
F9	42	CH	I	This pin should be set at a "L" level normally and be set at a "H" level when DMA is used.
H5	55	DREQL	O	When DMA transfer is selected, "H" level DREQL outputs a signal to request a DMA transfer. Active "H" can be changed to active "L".
J5	56	$\overline{DACKL}$	I	Input to $\overline{DACKL}$ a signal when DMA transfer is permitted by the DMA controller. when DACKL is "L", $\overline{IOW}$ and $\overline{IOR}$ signals are accepted. Active "L" can be changed to active "H" by command input. If DMA transfer is not used, set this pin to "H" level.
G6	54	$\overline{IOW}$	I	Write pulse Input pin to write external memory data to ML2302 during DMA transfer. If DMA transfer is not used, set this pin to "H" level.
J6	53	$\overline{IOR}$	I	Read pulse input pin to read data of ML2302 during DMA transfer. If DMA transfer is not used, set this pin to "H" level.
H4	59	ADSD	I	16-bit serial data input pin when external A/D converter is used. If external A/D converter is not used, set this pin to "L" level.
G4	60	DASD	O	16-bit serial data input pin when external D/A converter is used.

Pin (WCSP)	Pin (TQFP)	Symbol	Type	Description
J3	61	SIOCK	I/O	16-bit serial data transfer clock when external A/D or D/A converter is used.
J4	58	VCK	I/O	Outputs sampling frequency selected. Input pin when slave mode is selected.
J7 H7	51 50	XT $\overline{\text{XT}}$	I O	Oscillator connection pins. when external clock is used, input clock into XT pin and leave $\overline{\text{XT}}$ pin open. Oscillation stops during reset or power down mode. Figure (a) shows Oscillation Equivalent Circuit.
E9	40	$\overline{\text{RESET}}$	I	When this pin is "L", the LSI is initialized and AOUT is set to the GND level.
E8	39	FIFOST	I	When this pin is "L", EMP, MID, and FULL of playback FIFO can be monitored. When this pin is "H", EMP, MID, and FULL of record FIFO can be monitored.
B3	18	SG	O	Analog circuit signal ground pin. This pin is connected to GND during reset or power down mode.
A4 C4	22 20	MIN LIN	I	Inverting input pin for built-in OP amplifier. Non-inverting input pin is connected to SG (Signal Ground).
B4 A3	21 19	MOUT LOUT	O	MOUT is the output of internal OP amplifier to MIN, and LOUT is to LIN.
A5	25	AOUT	O	This is the output of the analog playback waveform.
H6	52	VOXO	O	Voice level detection signal
H8, B2	49, 16	TEST0, 8	I	Pins for testing. Set the pins to "L".
E3, G8	9, 46	DV <sub>DD</sub>	—	Digital power supply pin. Insert a minimum 0.1 $\mu\text{F}$ bypass capacitor between this pin and DGND pin
D7, G5	38, 57	DGND	—	Digital GND pin.
A2, B8	17, 33	AV <sub>DD</sub>	—	Analog power supply pin. Insert a minimum 0.1 $\mu\text{F}$ bypass capacitor between this pin and AGND pin.
C5, A8	23, 32	AGND	—	Analog GND pin.
C9, D8	36 35	CB1 CB2	O	This pin is used to connect a capacitor for voltage multiplier power supply. Insert a 1 $\mu\text{F}$ capacitor between CB1 and CB2.
C8	34	SPV <sub>DD</sub>	O	Voltage multiplier power supply output pin for speaker amplifier. Connect a 1 $\mu\text{F}$ capacitor to this pin in order to stabilize the speaker amplifier circuit.
D9	37	VR	O	Bias output pin for speaker amplifier. Set this pin to the GND level during reset or power down mode.
A6	26	SPIN	I	Voice signal input pin for speaker amplifier.
B6	27	SPOUT-	O	Speaker amplifier output pin. This pin outputs a signal in reverse phase to the signal that is input to the SPIN pin.
C6	28	SPOUT+	O	Speaker amplifier output pin. This pin outputs a signal in phase to the signal that is input to the SPIN pin.
D1, D2, D3, C1, C2, B1, B5	10~15 ,24	TEST2 to 7, 9	O	Pins for testing. Leave these pins open.

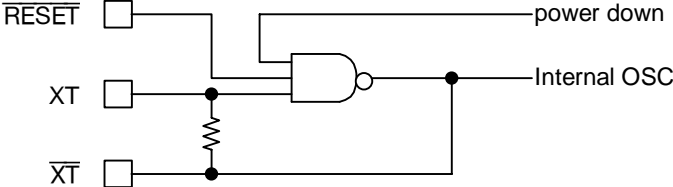

Figure (a) Oscillation Equivalent Circuit

**ABSOLUTE MAXIMUM RATINGS**

Parameter	Symbol	Condition	Rating	Unit
Power Supply Voltage	$V_{DD}$	Ta = 25°C	-0.3 to +7.0	V
Input Voltage	$V_{IN}$		-0.3 to $V_{DD} + 0.3$	V
Maximum Power Dissipation	PD		689.6	mW
Temperature Storage	$T_{STG}$	—	-55 to +150	°C

**RECOMMENDED OPERATING CONDITIONS**

Parameter	Symbol	Condition	Rating	Unit
Power Supply Voltage	$V_{DD}$	DGND = AGND = 0 V	+2.7 to +3.6	V
Operating Temperature	$T_{Op}$	—	-10 to +70	°C
Master Clock Frequency	$f_{OSC}$	—	16.384	MHz
Speaker Amplifier Load Impedance	$R_{LSP}$	—	8 to $\infty$	$\Omega$

## ELECTRICAL CHARACTERISTICS

### DC Characteristics

( $DV_{DD} = AV_{DD} = 2.7$  to  $3.6$  V,  $DGND = AGND = 0$  V,  $T_a = -10$  to  $+70^\circ\text{C}$ )

Parameter	Symbol	Condition	Min.	Typ.	Max.	Unit
High-level Input Voltage	$V_{IH}$	—	$0.85 \times V_{DD}$	—	—	V
Low-level Input Voltage	$V_{IL}$	—	—	—	$0.15 \times V_{DD}$	V
High-level Output Voltage (*1, *5)	$V_{OH1}$	$I_{OH} = -40 \mu\text{A}$	$V_{DD} - 0.3$	—	—	V
High-level Output Voltage (*2, *5)	$V_{OH2}$		$V_{DD} - 0.3$	—	—	V
Low-level Output Voltage (*1, *5)	$V_{OL1}$	$I_{OL} = 2 \text{ mA}$	—	—	0.45	V
Low-level Output Voltage (*2, *5)	$V_{OL2}$		—	—	0.8	V
High-level Input Current (*3)	$I_{IH1}$	$V_{IH} = V_{DD}$	—	—	10	$\mu\text{A}$
High-level Input Current (*4)	$I_{IH2}$		1	—	7	$\mu\text{A}$
Low-level Input Current (*3)	$I_{IL1}$	$V_{IL} = \text{GND}$	-10	—	—	$\mu\text{A}$
Low-level Input Current (*4)	$I_{IL2}$		-7	—	-1	$\mu\text{A}$
Operating Current Consumption	$I_{DD}$	$f_{osc} = 16 \text{ MHz}$ , without load	—	15	20	mA
Standby Current Consumption	$I_{DDs}$	At reset, without load $T_a = -10$ to $+50^\circ\text{C}$	—	—	10	$\mu\text{A}$
		At reset, without load $T_a = +50$ to $+70^\circ\text{C}$	—	—	50	$\mu\text{A}$

\*1 : Applied to input pins excluding  $\overline{XT}$  pin.

\*2 : Applied to  $\overline{XT}$  pin.

\*3 : Applied to output pins excluding XT pin.

\*4 : Applied to XT pin.

\*5 : If an output pin is shortcircuited to  $V_{DD}$  or GND, the LSI may be damaged.

### Analog Characteristics

( $DV_{DD} = AV_{DD} = 2.7$  to  $3.6$  V,  $DGND = AGND = 0$  V,  $T_a = -10$  to  $+70^\circ\text{C}$ )

Parameter	Symbol	Condition	Min.	Typ.	Max.	Unit
D/A Output Relative Error	$ V_{DAE} $	Without load	—	—	40	mV
LOUT Allowable Voltage Range	$V_{LOUT}$	$V_{DD} = 3$ V	0.75	—	2.25	V
OP Amplifier Open Loop Gain	$G_{OP}$	$f_{in} = 0$ to $4$ kHz	40	—	—	dB
DAC Output Impedance	$R_{DAO}$	DAC output is selected $AOUT = 1/2V_{DD}$	30	50	70	$k\Omega$
OP Amplifier Input Impedance	$R_{INA}$	(Excluding MIC amplifier)	1	—	—	$M\Omega$
MIC Amplifier Input Impedance	$R_{INAM}$	MIC amplifier	8.1	11.6	15.1	$k\Omega$
MOUT, LOUT Load Resistance	$R_{OUTA}$	—	50	—	—	$k\Omega$
AOUT Load Resistance	$R_{AOL}$	—	50	—	—	$k\Omega$
VR Output Voltage	$V_{VR}$	—	1.22	1.25	1.28	V
SG Output Voltage	$V_{SG}$	$V_{DD} = 3.0$ V	1.47	1.5	1.53	V
SPIN Input Impedance	$R_{ISP}$	—	1	—	—	$M\Omega$
Voltage Gain	AV1	SPIN $\rightarrow$ SPOUT– (Loop resistor is not connected) $f_{IN} = 10$ kHz	40	—	—	dB
	AV2	SPOUT– $\rightarrow$ SPOUT+	–0.4	0	0.4	dB
Differential Output Power	PD1	$V_{DD} = 3.0$ V $R_L = 8\Omega$ THD $\geq 10\%$	100	—	—	mW
SPOUT+/- Output Voltage	$V_{SP}$	No signal is input.	1.17	1.25	1.33	V
SPOUT+/- Output Offset Voltage	$V_{SPOF}$	No signal is input.	—	—	$\pm 50$	mV
SPOUT+/- Output "H" Voltage	$V_{SPH}$	$I_{OH} = +10$ mA	2.2	—	—	V
SPOUT+/- Output "L" Voltage	$V_{SPL}$	$I_{OL} = -10$ mA	—	—	0.25	V

## FUNCTIONAL DESCRIPTION

### Voice Synthesis Algorithms

The ML2302 supports five PCM algorithms to process various kinds of voices.

1. 4-bit OKIADPCM algorithm
2. 4/5/6/7/8-bit OKIADPCM2 algorithm
3. 2-bit OKIADPCM algorithm
4. 8/16-bit straight PCM algorithm
5. 8-bit OKI Non-linear PCM algorithm

### Voice Synthesis Algorithms and Sampling Frequencies during Recording and Playback

The relationships between the voice synthesis algorithms and sampling frequencies available during recording and playback are shown in Tables 1.1.1 and 1.1.2.

**Table 1.1.1 During Recording**

$f_{\text{sam}}$ (kHz)	4.0	5.3	6.1	6.4	8.0	9.8	10.7	11.6	12.8	14.2	16.0	18.3	21.3	25.6
Voice synthesis algorithm														
4-bitADPCM	○	○	○	○	○	○	○	○	○	×	×	×	×	×
4/5/6/7/8-bitADPCM2	○	○	○	○	○	○	○	○	○	×	×	×	×	×
2-bitADPCM2	○	○	○	○	○	○	○	○	○	×	×	×	×	×
8-bit straight PCM	○	○	○	○	○	○	○	○	○	○	○	○	○	○
16-bit straight PCM	○	○	○	○	○	○	○	○	○	○	○	○	×	×
8-bit Non-linear PCM	×	×	×	×	×	×	×	×	×	×	×	×	×	×

**Table 1.1.2 During Playback**

$f_{\text{sam}}$ (kHz)	4.0	5.3	6.1	6.4	8.0	9.8	10.7	11.6	12.8	14.2	16.0	18.3	21.3	25.6
Voice synthesis algorithm														
4-bitADPCM	○	○	○	○	○	○	○	○	○	×	×	×	×	×
4/5/6/7/8-bitADPCM2	○	○	○	○	○	○	○	○	○	×	×	×	×	×
2-bitADPCM	○	○	○	○	○	○	○	○	○	×	×	×	×	×
8-bit straight PCM	○	○	○	○	○	○	○	○	○	○	○	○	○	○
16-bit straight PCM	○	○	○	○	○	○	○	○	○	○	○	○	×	×
8-bit Non-linear PCM	○	○	○	○	○	○	○	○	○	○	○	○	×	×

## Data Configuration

The data configuration of each voice synthesis algorithm is shown in Tables 1.2.1 to 1.2.7.

**Table 1.2.1 2-bitADPCM2 Algorithm**

D7	D6	D5	D4	D3	D2	D1	D0
MSB1	LSB1	MSB2	LSB2	MSB3	LSB3	MSB4	LSB4

**Table 1.2.2 4-bitADPCM Algorithm, 4-bit ADPCM2 Algorithm**

D7	D6	D5	D4	D3	D2	D1	D0
MSB1	3SB1	2SB1	LSB1	MSB2	3SB2	2SB2	LSB2

**Table 1.2.3 5-bitADPCM2 Algorithm**

D7	D6	D5	D4	D3	D2	D1	D0
×	×	×	MSB1	4SB1	3SB1	2SB1	LSB1

**Table 1.2.4 6-bitADPCM2 Algorithm**

D7	D6	D5	D4	D3	D2	D1	D0
×	×	MSB1	5SB1	4SB1	3SB1	2SB1	LSB1

**Table 1.2.5 7-bitADPCM2 Algorithm**

D7	D6	D5	D4	D3	D2	D1	D0
×	MSB1	6SB1	5SB1	4SB1	3SB1	2SB1	LSB1

**Table 1.2.6 8-bit ADPCM2 Algorithm,  
8-bit Non-linear PCM Algorithm, 8-bit straight PCM Algorithm**

D7	D6	D5	D4	D3	D2	D1	D0
MSB1	7SB1	6SB1	5SB1	4SB1	3SB1	2SB1	LSB1

**Table 1.2.7 16-bit straight PCM Algorithm**

D7	D6	D5	D4	D3	D2	D1	D0	
MSB1	15SB1	14SB1	13SB1	12SB1	11SB1	10SB1	9SB1	(first)
8SB1	7SB1	6SB1	5SB1	4SB1	3SB1	2SB1	LSB1	(second)

×: Don't care

## FIFO Memory Configuration

The ML2302 has two FIFO memories; one is for recording and other is for playback.

The configuration of FIFO memory can be changed with a command. Select a FIFO configuration considering buffering times.

Initially, FIFO memory for recording and FIFO memory for playback each is provided with 1024 bits (128 words  $\times$  8 bits).

ML2302 cannot command recording and playback at the same time.

### 1. Combination of FIFO memory capacities

Table 1.3.1 shows the combination of FIFO memory capacities in recording and playback modes.

**Table 1.3.1**

Mode \ Capacity	Recording	Playback	
1024 bits	128 w $\times$ 8 bits	128 w $\times$ 8 bits	*Initial value
512 bits	64 w $\times$ 8 bits	64 w $\times$ 8 bits	
256 bits	32 w $\times$ 8 bits	32 w $\times$ 8 bits	

### 2. Voice synthesis algorithms and maximum buffering times

Table 1.3.2 shows the maximum buffering times when the FIFO capacity is 1024 bits and the sampling frequency is 8 kHz.

**Table 1.3.2**

Mode \ Voice synthesis algorithm	Recording	Playback
4-bit OKIADPCM	32 ms	32 ms
4-bit OKIADPCM2	32 ms	32 ms
5/6/7/8-bit OKIADPCM2	16 ms	16 ms
2-bit OKIADPCM2	64 ms	64 ms
8-bit straight PCM	16 ms	16 ms
16-bit straight PCM	8 ms	8 ms
8-bit OKI Non-linear PCM	Note)	16 ms

Note: The 8-bit OKI Non-linear PCM algorithm cannot be used during recording.

**COMMAND LIST****Table 2.1**

D7	D6	D5	D4	D3	D2	D1	D0	Function
0	0	0	0	W3	W2	0	0	POWER DOWN
0	0	0	1	X	X	X	X	Disable
0	0	1	0	S3	S2	S1	S0	Sets sampling frequency.
0	0	1	1	C3	C2	C1	C0	RECORDING, PLAYBACK, STOP, PAUSE
0	1	0	0	VH3	VH2	VH1	VH0	Volume control 1
0	1	0	1	VL3	VL2	VL1	VL0	Volume control 2
0	1	1	0	0	K2	K1	K0	Level detection, noise injection
0	1	1	1	P3	P2	P1	P0	Voice synthesis algorithm
1	0	0	0	R3	R2	R1	0	Analog specification 1
1	0	0	1	A3	A2	A1	0	Analog specification 2
1	0	1	0	0	B2	B1	B0	FIFO memory byte configuration
1	0	1	1	F3	F2	F1	0	Signal output format
1	1	0	0	G3	G2	G1	G0	DMA Transfer
1	1	0	1	I3	0	J1	J0	Serial port
1	1	1	0	U3	U2	U1	U0	Fast Forward/Rewind setting 1 (quick speaking/slow speaking)
1	1	1	1	Y3	Y2	Y1	Y0	Fast Forward/Rewind setting 2

## READING STATUS

The ML2302 supports the following seven status flags.

**Table 4.1**

Pin	Status	Description
D7	Data Recording/Playing flag	High when recording or playback is in progress
D6	Don't Care	
D5	Pause flag	High when playback of left voice is paused
D4	Don't Care	
D3	EMP Information Output flag	Output the same signal as the EMP pin. Note)
D2	MID Information flag	Output the same signal as the MID pin. Note)
D1	FUL Information flag	Output the same signal as the FUL pin. Note)
D0	Data Transfer Error flag	See "Data Transfer Errors".

Note: EM, MID, and FUL are either at the active "H" or at the active "L" by setting the signal output format by the command. The status signals on D3 to D1 are determined depending on the status of the FIFOST pin as shown below.

	FIFOST = "0"	FIFOST = "1"
D3	EMP signal for playback FIFO	EMP signal for recording FIFO
D2	MID signal for playback FIFO	MID signal for recording FIFO
D1	FUL signal for playback FIFO	FUL signal for recording FIFO

## Data Transfer Errors

The Data Transfer flag supports the following four errors.

- (1) "H" when data is read while EMP for recording FIFO is "H"
- (2) "H" when data is written while FUL for playback FIFO is "H"
- (3) "H" when a command is written while CBUSY is "L".
- (4) "H" when recording data cannot be written in FIFO while FUL for recording FIFO is "H".

\*These four errors are released when a normal transfer described below is carried out.

- (1) Reads data while EMP for recording FIFO is "L".
- (2) Writes data while FUL for playback FIFO is "L".
- (3) Writes a command while CBUSY is "H".
- (4) The error flag is released when data is written in recording FIFO within LSI after reading data from recording FIFO and setting FUL for recording FIFO to "L".

## ANALOG INPUT AMPLIFIER CIRCUIT

The ML2302 contains two OP amplifiers to amplify a voice signal from a microphone. Each OP amplifier is provided with the inverting input pin and output pin.

The analog circuit reference voltage SG (signal ground) is input internally to the non-inverting input of each amplifier.

For amplification, form an inverting amplifier circuit and adjust the amplification ratio by using external resistors.

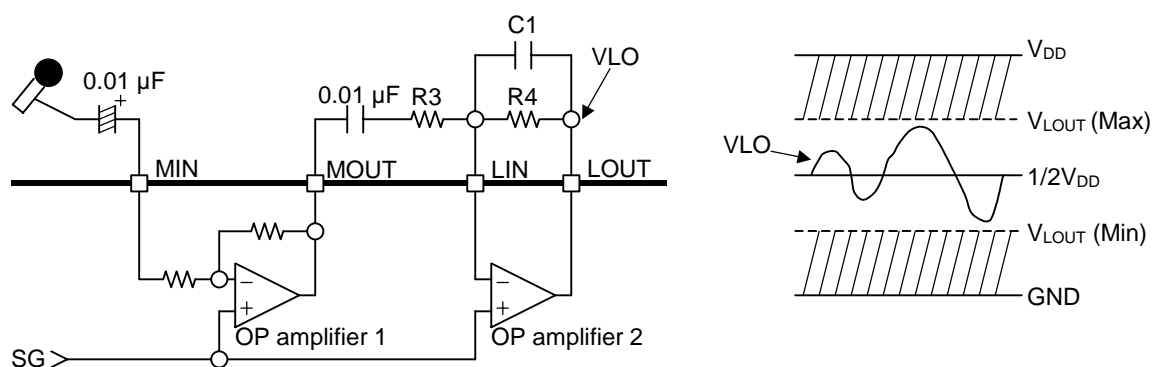

Figure 6.1

The constants of R4 and C1 are determined by  $f = 1/2\pi R \cdot C$ . C1 is  $39.89 \text{ pF} \cong 39 \text{ pF}$  when R4 is  $200 \text{ k}\Omega$ , where the cut-off frequency of LPF is  $f = 20 \text{ kHz}$ .

During recording, the output VLO of the OP amplifier is input to LPF.

Adjust the amplification ratio by an external resistor so that the output voltage  $V_{\text{LOUT}}$  may be in the LOUT-permissible input voltage range.

If  $V_{\text{LOUT}}$  is not in this range, the waveform of the LPF output may be deformed.

Table 6.1 shows an examples of LOUT-permissible input voltage ranges of the ML2302.

Table 6.1

Model name	Supply voltage $V_{\text{DD}}$	LOUT-permissible voltage range $V_{\text{LOUT}}$		LOUT-permissible range
		MIN	MAX	
ML2302	3 V	0.75 V	2.25 V	$1.5 V_{\text{pp}}$

The load resistance  $R_{\text{OUTA}}$  of the OP amplifier is  $50 \text{ k}\Omega$ . Therefore, the feedback resistors R4 and R3 of the amplifying circuit must be  $50 \text{ k}\Omega$  or higher.

## SPEAKER DRIVING AMPLIFIER

The ML2302 contains two OP amplifiers for driving a speaker; SPOUT- which is the inverting type output for a voice multiplication signal SPIN and SPOUT+ which is the non-inverting type output. Though SPOUT+ alone can be used, when differential outputs are used, it is possible to gain not only an amplitude two times that of when a single OP amplifier is used but also a good volume even if a low power supply voltage is used. The connection diagram of differential outputs are shown below.

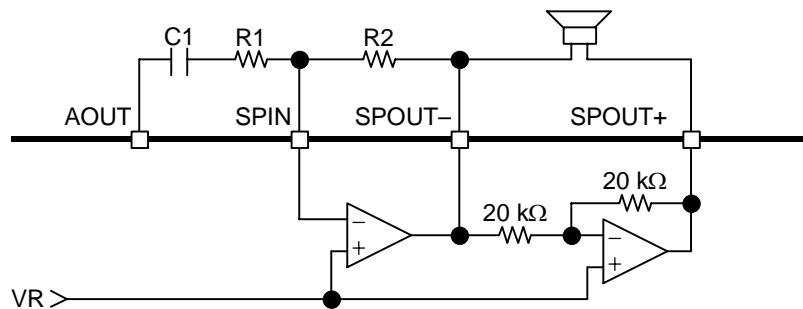

Note 1: The gain of a speaker amplifier is determined by R1 and R2.

$$V(\text{SPOUT-}) = -\frac{R2}{R1} \cdot V(\text{SPIN})$$

$$V(\text{SPOUT+}) = -V(\text{SPOUT-}) = \frac{R2}{R1} \cdot V(\text{SPIN})$$

Note 2: C1 is an AC coupling capacitance. The cut-off frequency at a low field is determined by the following equation.

Select a value of C1 in accordance with a pass band.

$$f_c = \frac{1}{2 \times \pi \times C1 \times R1} \text{ (Hz)}$$

## RECORDING TIME AND MEMORY CAPACITY

The recording time of the ML2302 is dependent on the storage capacitance of external memory, the sampling frequency, and the width of ADPCM bits that have been specified. The recording time of the ML2302 is expressed by

$$\text{Recording time} = \frac{\text{Memory size (in kbits)}}{\text{Sampling frequency (kHz)} \times \text{Width of ADPCM bits}} \times \frac{4080}{4096}$$

For example, when 8.0 kHz of sampling frequency, 4 bits of ADPCM2, and 8 Mbits of memory size are set, the recording time is calculated below.

$$\text{Recording time} = \frac{8000}{8.0 \times 4} \times \frac{4080}{4096} = 249 \text{ seconds} = 4 \text{ minutes } 9 \text{ seconds}$$

## CONNECTION OF POWER SUPPLY

The ML2302 contains a single power supply as shown in Figure 7.1. The power supply is connected to the analog unit and digital unit separately.

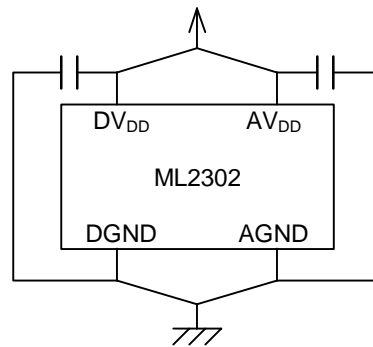

Figure 7.1

Avoid following power supply connections.

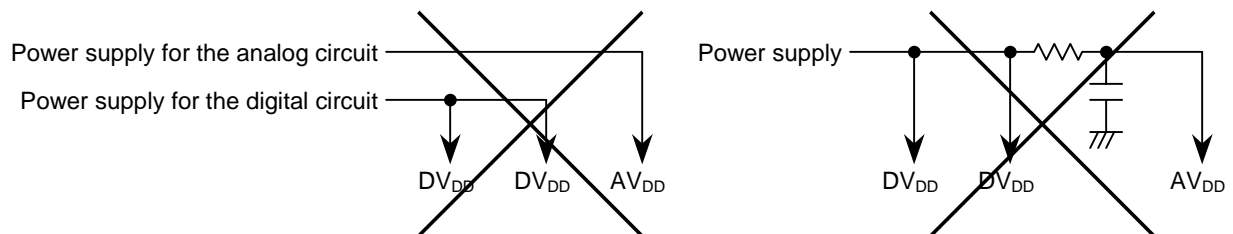
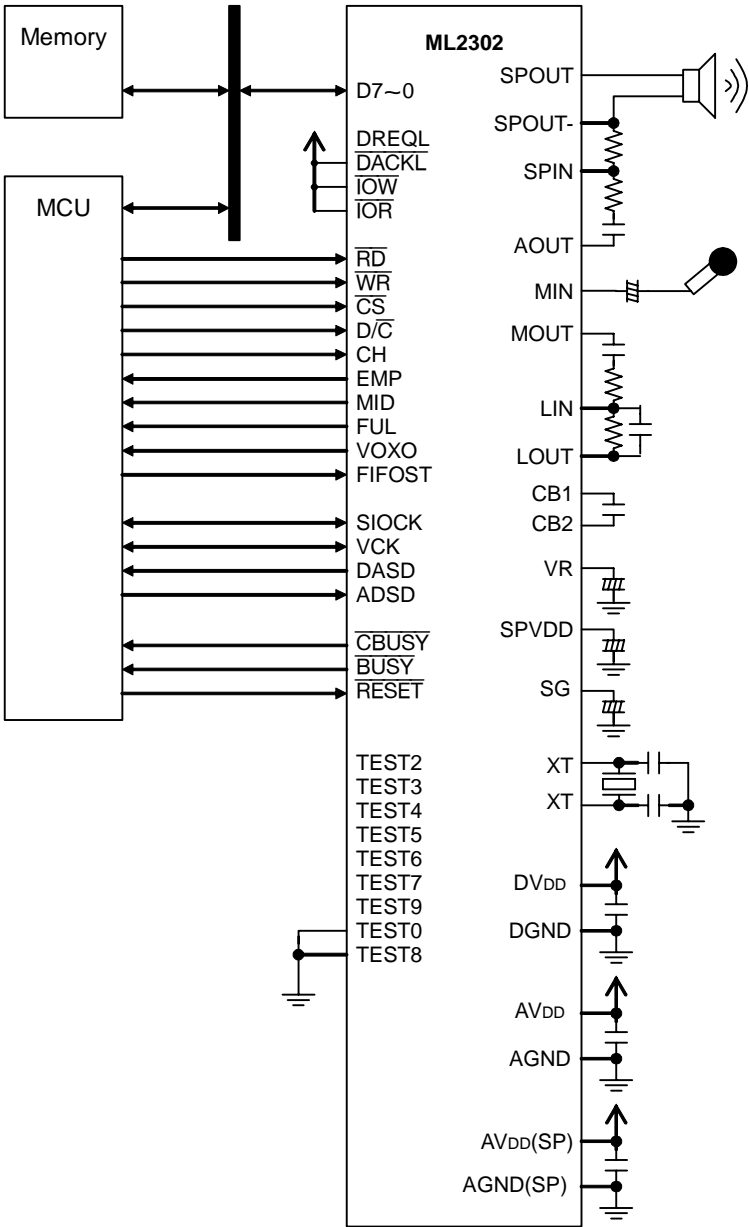

Figure 7.2

APPLICATION CIRCUIT EXAMPLE

(1) MCU and External Interface



(2) Interface when DMA controller is Used

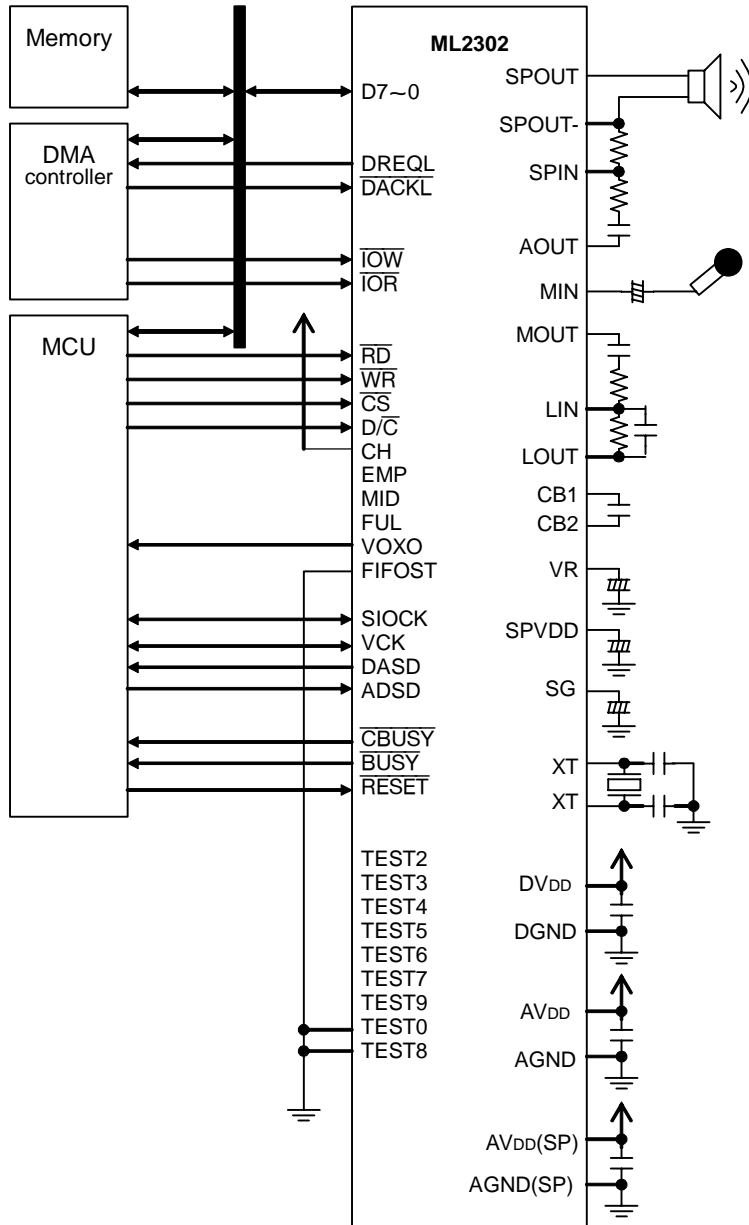



(Unit: mm)

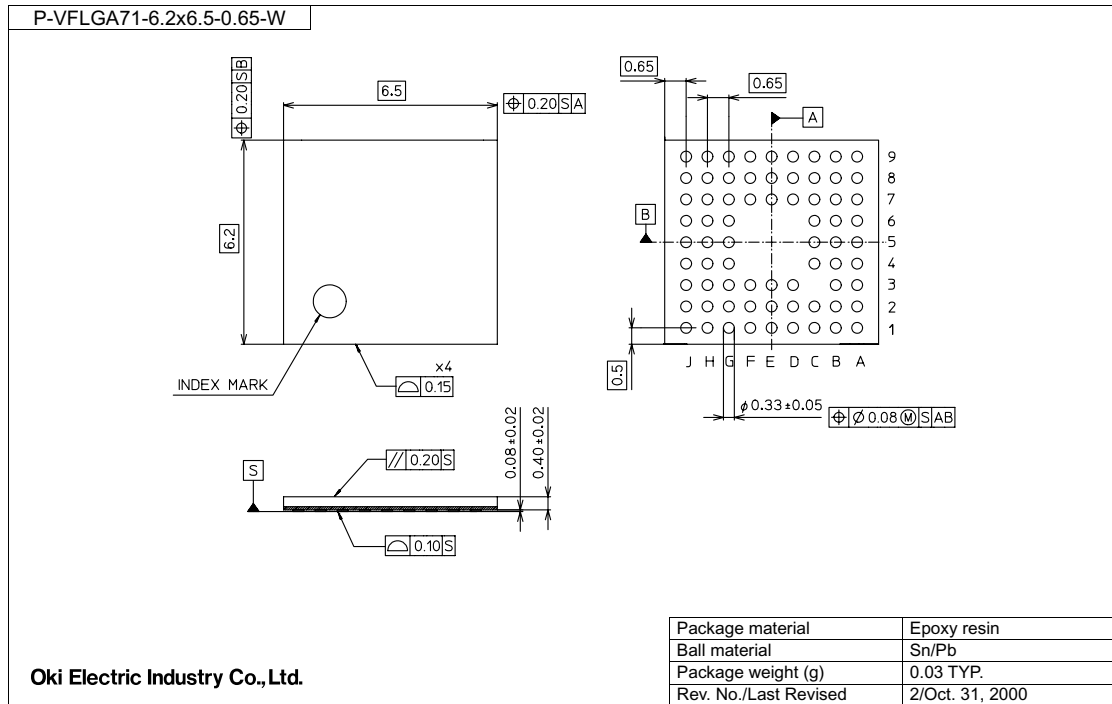

Notes for Mounting the Surface Mount Type Package

The surface mount type packages are very susceptible to heat in reflow mounting and humidity absorbed in storage. Therefore, before you perform reflow mounting, contact Oki's responsible sales person for the product name, package name, pin number, package code and desired mounting conditions (reflow method, temperature and times).

**REVISION HISTORY**

Document No.	Date	Page		Description
		Previous Edition	Current Edition	
FEDL2302DIGEST-01	Apr. 2001	–	–	Final edition 1
FEDL2302DIGEST-02	Apr. 3, 2003	–	–	Final edition 2
FEDL2302DIGEST-03	May 30, 2003	–	–	Final edition 3
FEDL2302DIGEST-04	Jan. 20, 2004	1	1	Partially changed contents of the "FEATURES" section.
		2	2	Modified the block diagram.
		–	10-18	Added pages.
FEDL2302DIGEST-05	Dec. 27, 2004	6	6	Partially corrected the Pin Descriptions.
		19	19,20	Modified the application circuit example.

NOTICE

1. The information contained herein can change without notice owing to product and/or technical improvements. Before using the product, please make sure that the information being referred to is up-to-date.
2. The outline of action and examples for application circuits described herein have been chosen as an explanation for the standard action and performance of the product. When planning to use the product, please ensure that the external conditions are reflected in the actual circuit, assembly, and program designs.
3. When designing your product, please use our product below the specified maximum ratings and within the specified operating ranges including, but not limited to, operating voltage, power dissipation, and operating temperature.
4. Oki assumes no responsibility or liability whatsoever for any failure or unusual or unexpected operation resulting from misuse, neglect, improper installation, repair, alteration or accident, improper handling, or unusual physical or electrical stress including, but not limited to, exposure to parameters beyond the specified maximum ratings or operation outside the specified operating range.
5. Neither indemnity against nor license of a third party's industrial and intellectual property right, etc. is granted by us in connection with the use of the product and/or the information and drawings contained herein. No responsibility is assumed by us for any infringement of a third party's right which may result from the use thereof.
6. The products listed in this document are intended for use in general electronics equipment for commercial applications (e.g., office automation, communication equipment, measurement equipment, consumer electronics, etc.). These products are not, unless specifically authorized by Oki, authorized for use in any system or application that requires special or enhanced quality and reliability characteristics nor in any system or application where the failure of such system or application may result in the loss or damage of property, or death or injury to humans.  
Such applications include, but are not limited to, traffic and automotive equipment, safety devices, aerospace equipment, nuclear power control, medical equipment, and life-support systems.
7. Certain products in this document may need government approval before they can be exported to particular countries. The purchaser assumes the responsibility of determining the legality of export of these products and will take appropriate and necessary steps at their own expense for these.
8. No part of the contents contained herein may be reprinted or reproduced without our prior permission.

Copyright 2004 Oki Electric Industry Co., Ltd.