

Rev. 03/27/2015

**Features**

- XTREMELY Low Jitter
- Low Cost
- XPRESS Delivery
- Frequency Resolution to six decimal places
- Stabilities to  $\pm 50$  PPM \*
- -20 to +70°C or -40 to +85°C operating temperatures
- Tri-State Enable / Disable Feature
- Industry Standard Package, Footprint & Pin-Out
- Fully RoHS compliant
- Gold over Nickel Termination Finish
- Serial ID with Comprehensive Traceability



**Applications**

- ANY application requiring an oscillator
- SONET
- Ethernet
- Storage Area Network
- Broadband Access
- Microprocessors / DSP / FPGA
- Industrial Controllers
- Test and Measurement Equipment
- Fiber Channel

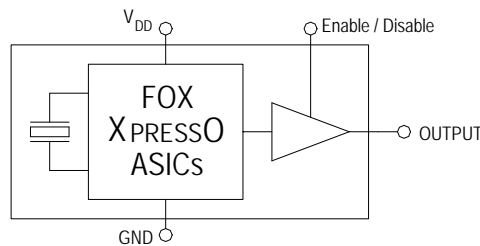

For more information -- Click on the drawing

**Description**

The Fox XPRESSO Crystal Oscillator is a breakthrough in configurable Frequency Control Solutions. XPRESSO utilizes a family of proprietary ASICs, designed and developed by Fox, with a key focus on noise reduction technologies.

The 3<sup>rd</sup> order Delta Sigma Modulator reduces noise to the levels that are comparable to traditional Bulk Quartz and SAW oscillators. The ASICs family has ability to select the output type, input voltages, and temperature performance features.

With the XPRESS lead-time, low cost, low noise, wide frequency range, excellent ambient performance, XpressO is an excellent choice over the conventional technologies.

Finished XPRESSO parts are 100% final tested.

**Contents**

	page
Model Selection & Part Number Guide	2
Electrical Characteristic	3
Absolute Maximums	3
Output Wave Characteristics	4
Phase Noise	5
Jitter	5
Pin Assignment	6
Recommended Circuit	6
Reflow	6
Mechanical Drawing and Pad Layout	7
Tape and Reel Specification	8
Label	8
Traceability – LOT Number & Serial Identification	9
Mechanical Test	10
Other XPRESSO Links	11
Fox Contact Information	11

*\*Tighter stabilities may be available. Contact Fox Technical Support for details.*

## Model Selection Guide & Fox Part Number

**STEP #1:** Customer selects the Model Description and provides to Fox Customer Service

### Model Description

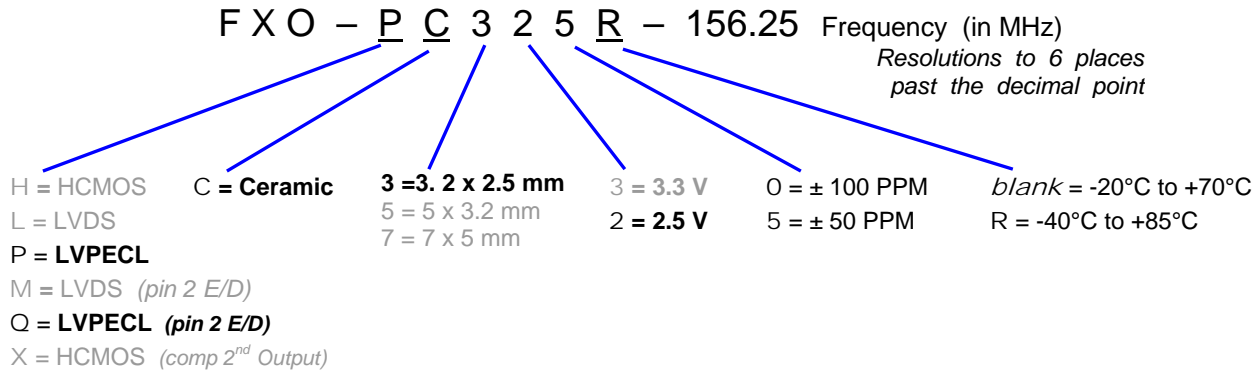

**STEP #2:** The Fox Customer Service team provides a customer specific Part Number for use on their Bill Of Materials (BOM).

**Fox Part Number** *(The assigned Fox Part Number must be on the BOM – not the above Model Description)  
 (This will ensure receipt of the proper part)*

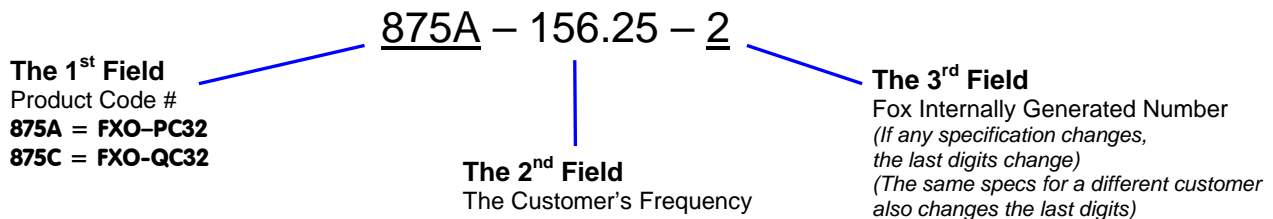

**This example, FXO-PC325R-156.25 = LVPECL Output, Ceramic, 3.2 x 2.5mm Package, 2.5V, ±50 PPM Stability, -40 to +85°C Temperature Range, at 156.25 MHz**

<b>Electrical Characteristics</b>			
<b>Parameters</b>	<b>Symbol</b>	<b>Condition</b>	<b>Maximum Value</b> (unless otherwise noted)
Frequency Range	F <sub>O</sub>		0.750 MHz to 160 MHz
Frequency Stability <sup>1</sup>			100, 50 PPM
Temperature Range	T <sub>O</sub> T <sub>STG</sub>	Standard operating <i>Optional operating</i> Storage	-20°C to +70°C -40°C to +85°C -55°C to +125°C
Supply Voltage	V <sub>DD</sub>	Standard	2.5 V ± 5%
Input Current (@ Standard Load)	I <sub>DD</sub>	0.750 ~ 20.000 MHz 20.000+ ~ 160.000 MHz	33 mA 41 mA
Output Load	I	Standard	50 Ohms into V <sub>DD</sub> -2V <sub>DC</sub> . TYP.
Start-Up Time	T <sub>S</sub>		10 mS
Output Enable / Disable Time			100 nS
Moisture Sensitivity Level	MSL	<i>JEDEC J-STD-020</i>	1
Termination Finish			Au

Note 1 – Stability is inclusive of 25°C tolerance, operating temperature range, input voltage change, load change, aging, shock and vibration.

<b>Absolute Maximum Ratings</b> <i>(Useful life may be impaired. For user guidelines only, not tested)</i>			
<b>Parameters</b>	<b>Symbol</b>	<b>Condition</b>	<b>Maximum Value</b> (unless otherwise noted)
Input Voltage	V <sub>DD</sub>		-0.5V to +5.0V
Operating Temperature	T <sub>AMAX</sub>		-55°C to +105°C
Storage Temperature	T <sub>STG</sub>		-55°C to +125°C
Junction Temperature			125°C
ESD Sensitivity	HBM	Human Body Model	1 kV

**Output Wave Characteristics**

Parameters	Symbol	Condition	Maximum Value (unless otherwise noted)
Low Output Voltage	$V_{OL}$	0.75 MHz to 160 MHz	0.68V Typ
High Output Voltage	$V_{OH}$	0.75 MHz to 160 MHz	1.4V Typ
Output Symmetry (See Drawing Below)		@ 50% $V_{P-P}$ Level	45% ~ 55%
Output Enable <sup>Note1</sup> (PIN # 1) Voltage	$V_{IH}$		$\geq 70\% V_{DD}$
Output Disable <sup>Note1</sup> (PIN # 1) Voltage	$V_{IL}$		$\leq 30\% V_{DD}$
Cycle Rise Time (See Drawing Below)	$T_R$	0.75 MHz to 160 MHz	400 pS (20%~80%)
Cycle Fall Time (See Drawing Below)	$T_F$	0.75 MHz to 160 MHz	400 pS (80%~20%)

<sup>Note1</sup> An optional PIN # 2 as Enable / Disable is available – see Model Selection Guide (page 2)

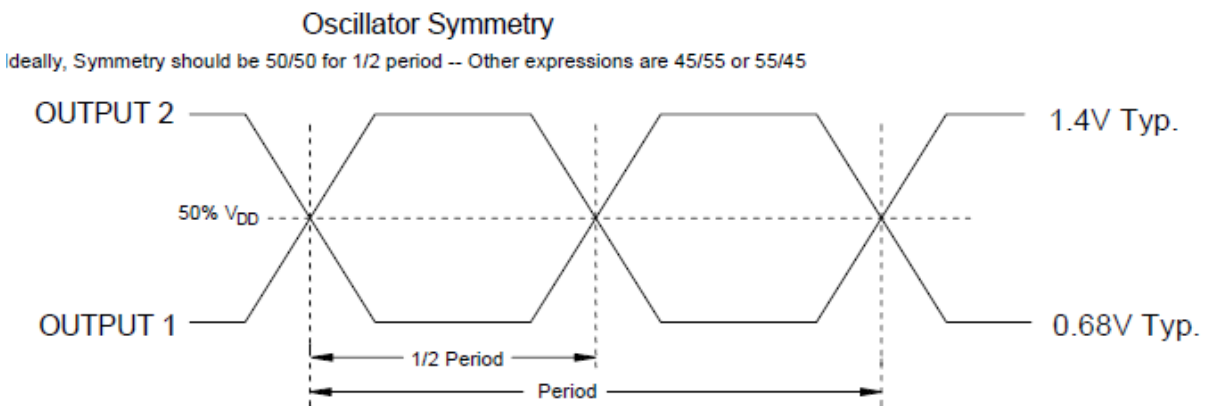
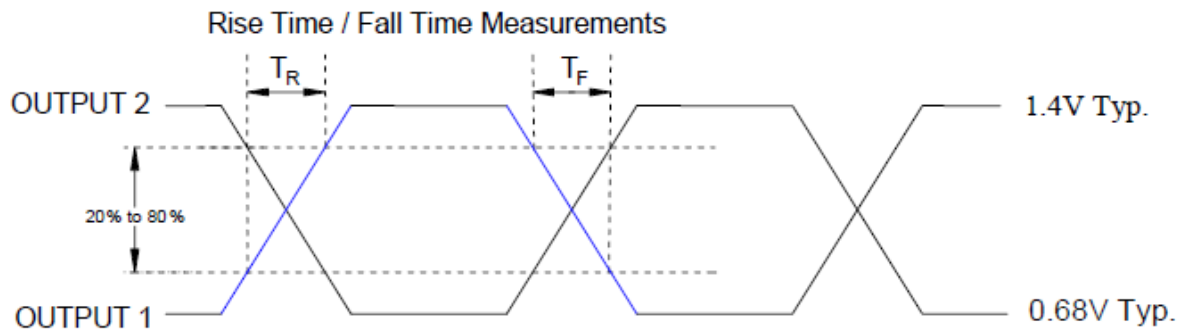

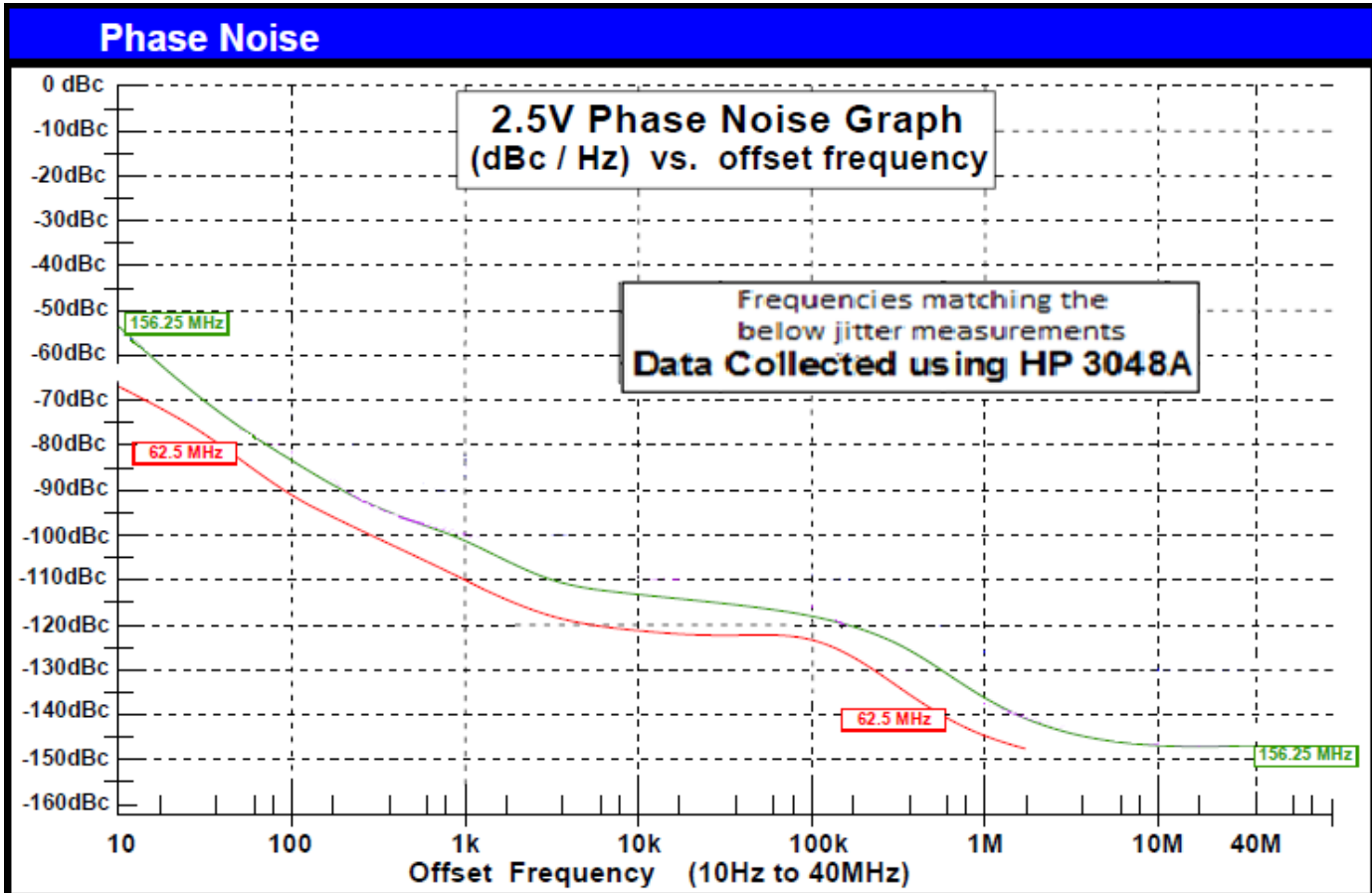

Jitter is frequency dependent. Below are typical values at select frequencies.

<b>LVPECL Phase Jitter &amp; Time Interval Error (TIE)</b>			
<b>Frequency</b>	<b>Phase Jitter</b> (12kHz to 20MHz)	<b>TIE</b> (Sigma of Jitter Distribution)	<b>Units</b>
62.5 MHz	2.10	3.1	pS RMS
156.25 MHz	1.20	3.5	pS RMS

**Phase Jitter** is integrated from HP3048 Phase Noise Measurement System; measured directly into 50 ohm input;  $V_{DD} = 2.5V$ .

**TIE** was measured on LeCroy LC684 Digital Storage Scope, directly into 50 ohm input, with Amherst M1 software;  $V_{DD} = 2.5V$ .

*Per MJSQ spec (Methodologies for Jitter and Signal Quality specifications)*

<b>LVPECL Random &amp; Deterministic Jitter Composition</b>			
<b>Frequency</b>	<b>Random (Rj)</b> (pS RMS)	<b>Deterministic (Dj)</b> (pS P-P)	<b>Total Jitter (Tj)</b> (14 x Rj) + Dj
62.5 MHz	1.35	10.5	30.5 pS
156.25 MHz	1.36	10.0	29.3 pS

**Rj and Dj**, measured on LeCroy LC684 Digital Storage Scope, directly into 50 ohm input, with Amherst M1 software.

*Per MJSQ spec (Methodologies for Jitter and Signal Quality specifications)*



**Pin Description and Recommended Circuit**

Pin #	Name	Type	Function
1	E / D <sup>1</sup>	Logic	Enable / Disable Control of Output (0 = Disabled)
2	NC <sup>2</sup>		No Connection – Leave OPEN
3	GND	Ground	Electrical Ground for V <sub>DD</sub>
4	Output	Output	LVPECL Oscillator Output
5	Output 2	Output	Differential LVPECL Output
6	V <sub>DD</sub> <sup>3</sup>	Power	Power Supply Source Voltage

**NOTES:**

- <sup>1</sup> Includes pull-up resistor to V<sub>DD</sub> to provide output when the pin (1) is No Connect. (Also see note 2)
- <sup>2</sup> An optional pin # 2 Enable / Disable is available.
- <sup>3</sup> Installation should include a 0.01µF bypass capacitor placed between V<sub>DD</sub> (Pin 6) and GND (Pin 3) to minimize power supply line noise.

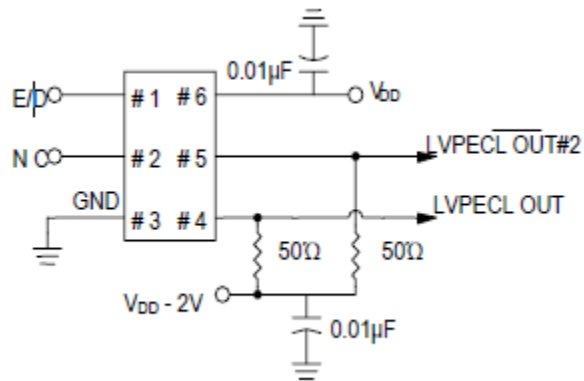
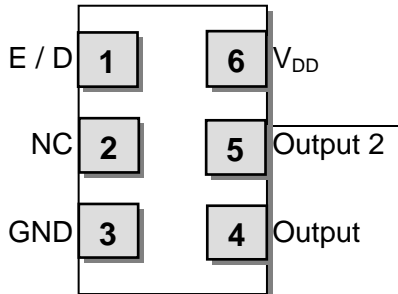

Terminations as viewed from the Top

**NOTE:** XPRESSO LVPECL XOs are designed to fit on Industry Standard, 6 pad layouts

**Enable / Disable Control**

Pin # 1 (state)	Output (Pin # 4, Pin # 5)
OPEN (No Connection)	ACTIVE Output
"1" Level $V_{IH} \geq 70\% V_{DD}$	ACTIVE Output
"0" Level $V_{IL} \leq 30\% V_{DD}$	High Impedance

**Soldering Reflow Profile (2 times Maximum at 260°C for 10 seconds MAX)**

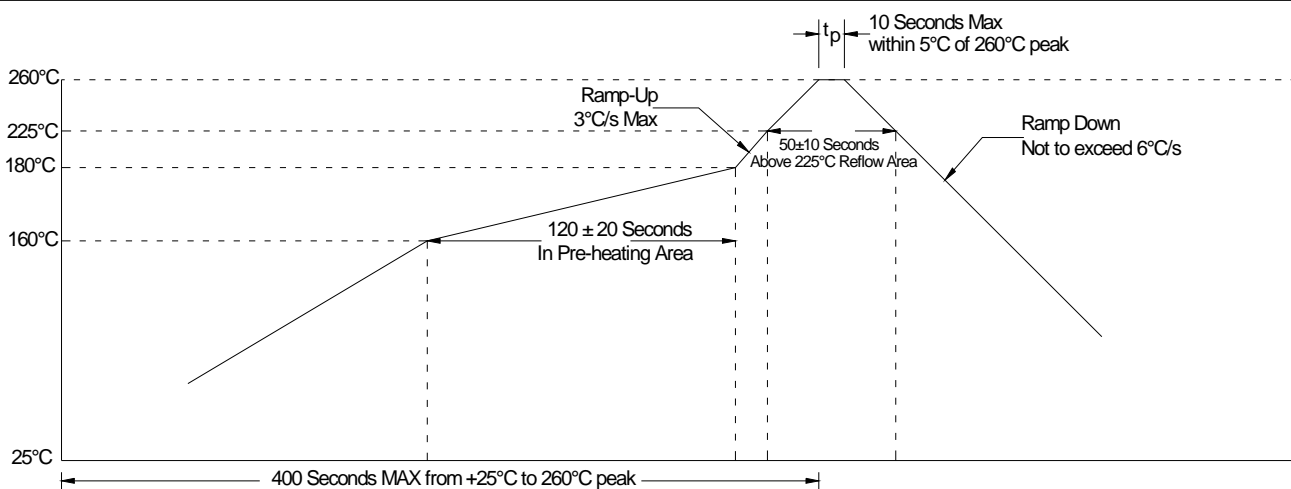

**Mechanical Dimensional Drawing & Pad Layout**

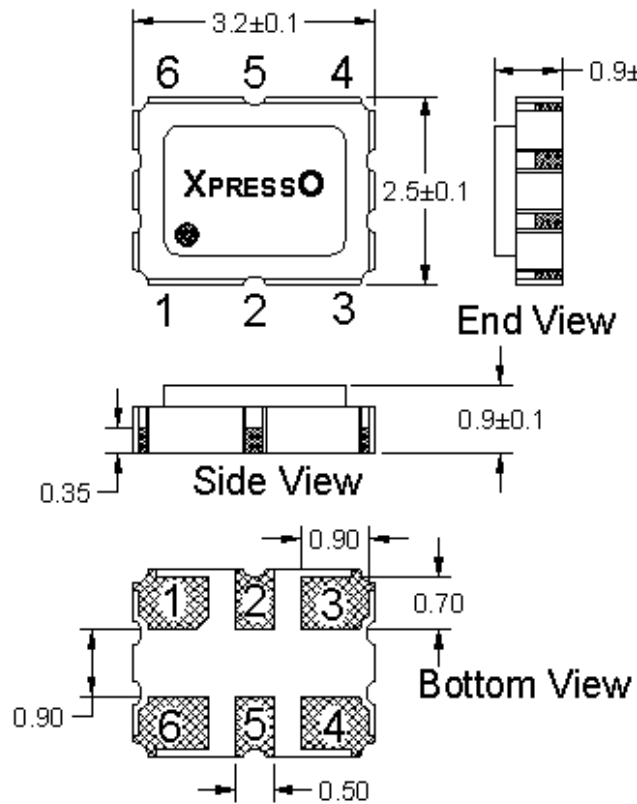

**Actual part marking is depicted.**  
See **Traceability** (pg. 9) for more information

**Recommended Solder Pad Layout**

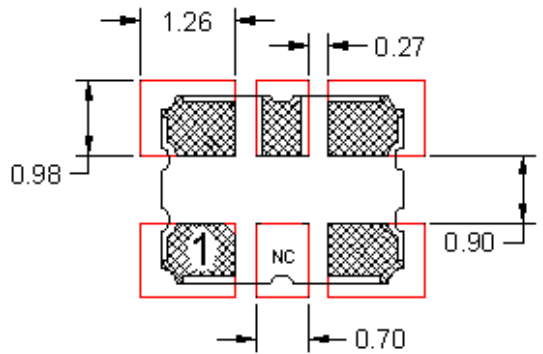

**Pin Connections**

- |                |                           |
|----------------|---------------------------|
| <b>#1) E/D</b> | <b>#4) Output</b>         |
| <b>#2) NC</b>  | <b>#5) Output 2</b>       |
| <b>#3) GND</b> | <b>#6) V<sub>DD</sub></b> |

Drawing is for reference to critical specifications defined by size measurements. Certain non-critical visual attributes, such as side castellations, reference pin shape, etc. may vary

**Tape and Reel Dimensions**

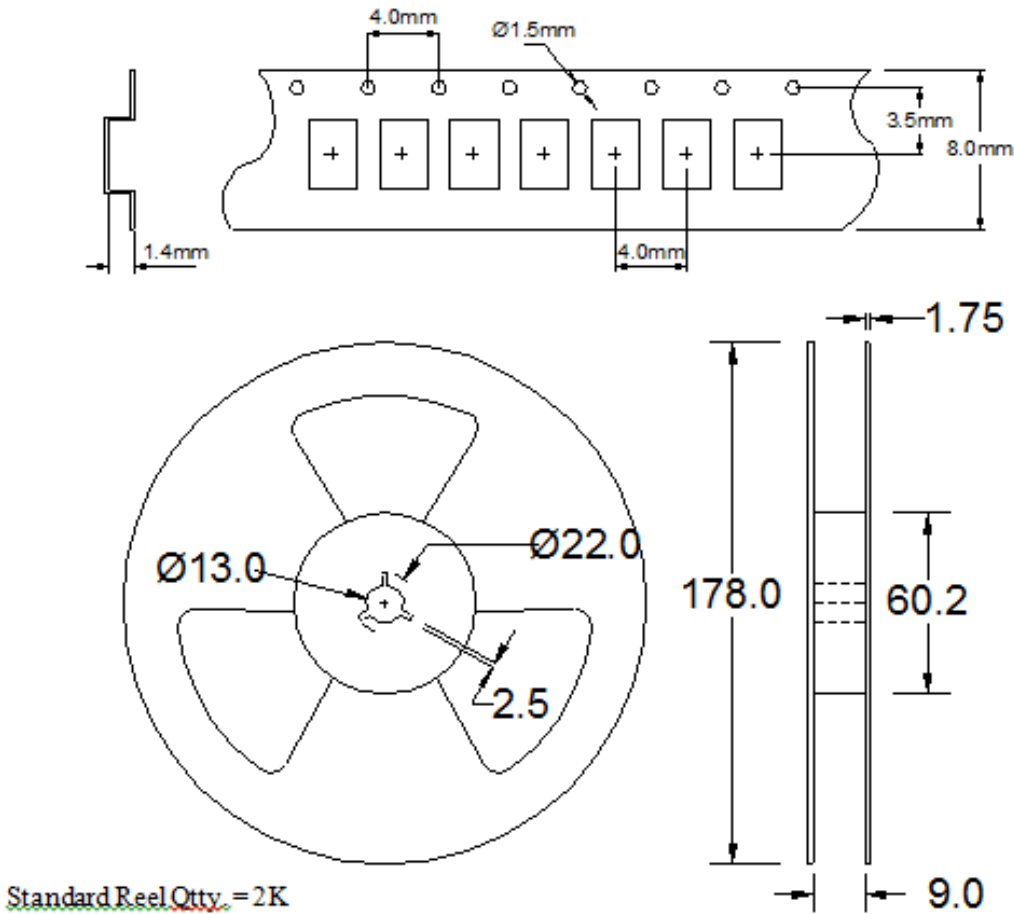

**Labeling** (Reels and smaller packaging are labeled with the below)

- Fox Part Number: **875A-156.25-2** →
- Quantity: **2000** pieces →
- Description: **FXO-PC325R-156.25** →
- Date Code: **0745** →  
(YYWW 2007 45<sup>th</sup> wk)
- LOT #: **24435** →  
*If traceability should become necessary*

SKU **875A-156.25-2**

QTY: 2000

DESC **FXO-PC325R-156.25**

DATE CODE: 0745

LOT: 24435

**Pb-Free  
RoHS Compliant  
Category (e4)**

**FOX**  
Xpresso®

Covered by one or more of listed  
U.S. Patents: 6,664,860, 5,960,403  
5,960,405 5,952,890 6,188,290  
Foreign Patents:  
China ZL 98802217.6 Mexico 232727  
R.S.A. 98/0806, ROC 120851,  
Singapore 67081; 67082,  
EP 0958052 Hong Kong HK1026079  
Malaysia MY-118540-A  
Philippines Patent: 1-1998-000246  
US and Foreign Patents Pending  
Xpresso® is a Registered Trademark of Fox Electronics

FOX Electronics

An additional identification code is contained internally if tracking should ever be necessary



## Traceability – LOT Number & Serial Identification

### LOT Number

The LOT Number has direct ties to the customer purchase order. The LOT Number is marked on the “Reel” label, and also stored internally on non-volatile memory inside the XPRESSO part. XPRESSO parts that are shipped Tape and Reel, are also placed in an Electro Static Discharge (ESD) bag and will have the LOT Number labeled on the exterior of the ESD bag.

It is recommended that the XPRESSO parts remain in this ESD bag during storage for protection and identification.

If the parts become separated from the label showing the LOT Number, it can be retrieved from inside one of the parts, and the information that can be obtained is listed below:

- Customer Purchase Order Number
- Internal Fox Sales Order Number
- Dates that the XPRESSO part was shipped from the factory
- The assigned customer part number
- The specification that the part was designed for

---

### Serial Identification

The Serial ID is the individualized information about the configuration of that particular XPRESSO part. The Serial ID is unique for each and every XPRESSO part, and can be read by special Fox equipment.

With the Serial ID, the below information can be obtained about that individual, XPRESSO part:

- Equipment that the XPRESSO part was configured on
- Raw material used to configure the XPRESSO part
- Traceability of the raw material back to the foundries manufacturing lot
- Date and Time that the part was configured
- Any optimized electrical parameters based on customer specifications
- Electrical testing of the actual completed part
- Human resource that was monitoring the configuration of the part

Fox has equipment placed at key Fox locations World Wide to read the Lot Identification and Serial Number of any XPRESSO part produced and can then obtain the information from above within 24 hours

**Mechanical Testing**

<b>Parameter</b>	<b>Test Method</b>
Mechanical Shock	Drop from 75cm to hardwood surface – 3 times
Mechanical Vibration	10~55Hz, 1.5mm amplitude, 1 Minute Sweep 2 Hours each in 3 Directions (X, Y, Z)
High Temperature Burn-in	Under Power @ 125°C for 2000 Hours (results below)
Hermetic Seal	He pressure: 4 ±1 kgf / cm <sup>2</sup> 2 Hour soak

XpressO-ULTRA Home

XpressO-ULTRA XOs

XpressO Brochure

Patent Numbers:

US 6,664,860, US 5,960,403, US 5,952,890; US 5,960,405; US 6,188,290;  
Foreign Patents: R.S.A. 98/0866, R.O.C. 120851; Singapore 67081, 67082; EP 0958652  
China ZL 98802217.6, Malaysia MY-118540-A, Philippines 1-1998-000245, Hong Kong #HK1026079, Mexico #232179  
US and Foreign Patents Pending  
XpressO® Fox Electronics

**Contact Information**

[\(USA\)-Worldwide Headquarters](#)

Tel: 888-GET-2-FOX  
Outside US: +1.239.693.0099,  
Fax: +1.239.693.1554  
Email: [www.foxonline.com/email.htm](http://www.foxonline.com/email.htm)

[Fox EMEA](#)

Tel: +44.1283.568153  
Email: [www.foxonline.com/email.htm](http://www.foxonline.com/email.htm)

[Fox Singapore](#)

Tel: +886-2-22073427,  
Email: [www.foxonline.com/email.htm](http://www.foxonline.com/email.htm)

The above specifications, having been carefully prepared and checked, is believed to be accurate at the time of publication; however, no responsibility is assumed by Fox Electronics for inaccuracies.