

**MXF** シリーズ  
SERIES

基板自立形105°C薄形品  
105°C Low profile, Snap-in Terminal Type

◆特長 FEATURES

- 105°C2000時間、高さ20mm品。  
Load Life : 105°C 2000 hours with 20mm height.

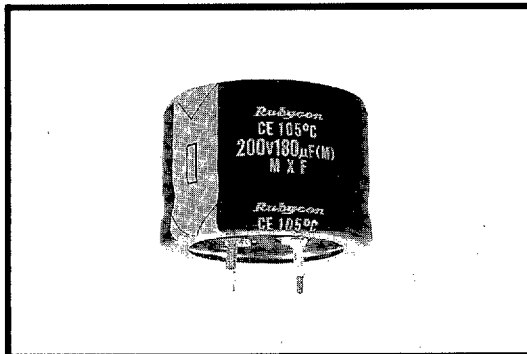

◆規格表 SPECIFICATIONS

項目 Items	特性 Characteristics																							
使用温度範囲 Operating Temperature Range	-40~+105°C	-25~+105°C																						
定格電圧範囲 Rated Voltage Range	10~100V.DC	160~400V.DC																						
静電容量許容差 Capacitance Tolerance	±20% (20°C, 120Hz)																							
漏れ電流 Leakage Current(MAX)	$I=3\sqrt{CV}$ (定格電圧印加5分後) $I=3\sqrt{CV}$ (After 5 minutes application of rated voltage) I=漏れ電流(μA)      V=定格電圧(V)      C=公称静電容量(μF) Leakage Current      Rated Voltage      Nominal Capacitance																							
損失角の正接 (tanδ) Dissipation Factor(MAX)	<table border="1"> <thead> <tr> <th>定格電圧(V) Rated Voltage</th> <th>10</th> <th>16</th> <th>25</th> <th>35</th> <th>50</th> <th>63</th> <th>80</th> <th>100</th> <th>160~250</th> <th>315~400</th> </tr> </thead> <tbody> <tr> <td>tanδ</td> <td>0.55</td> <td>0.50</td> <td>0.45</td> <td>0.40</td> <td>0.35</td> <td>0.30</td> <td>0.25</td> <td>0.20</td> <td>0.15</td> <td>0.25</td> </tr> </tbody> </table> (20°C, 120Hz)		定格電圧(V) Rated Voltage	10	16	25	35	50	63	80	100	160~250	315~400	tanδ	0.55	0.50	0.45	0.40	0.35	0.30	0.25	0.20	0.15	0.25
定格電圧(V) Rated Voltage	10	16	25	35	50	63	80	100	160~250	315~400														
tanδ	0.55	0.50	0.45	0.40	0.35	0.30	0.25	0.20	0.15	0.25														
インピーダンス比 Impedance Ratio(MAX)	<table border="1"> <thead> <tr> <th>定格電圧(V) Rated Voltage</th> <th>10~100</th> <th>160~250</th> <th>315~400</th> </tr> </thead> <tbody> <tr> <td>Z(-25°C)/Z(20°C)</td> <td>3</td> <td>3</td> <td>8</td> </tr> <tr> <td>Z(-40°C)/Z(20°C)</td> <td>12</td> <td></td> <td></td> </tr> </tbody> </table> (120Hz)		定格電圧(V) Rated Voltage	10~100	160~250	315~400	Z(-25°C)/Z(20°C)	3	3	8	Z(-40°C)/Z(20°C)	12												
定格電圧(V) Rated Voltage	10~100	160~250	315~400																					
Z(-25°C)/Z(20°C)	3	3	8																					
Z(-40°C)/Z(20°C)	12																							
高温負荷特性 Load Life	105°C, 2000時間定格電圧印加後 (リップル重畳) After 2000 hours application of rated voltage at 105°C(with rated ripple current). <table border="1"> <tbody> <tr> <td>静電容量変化率 Capacitance Change</td> <td>初期値の±20%以内 Within ±20% of the initial value.</td> </tr> <tr> <td>損失角の正接 Dissipation Factor</td> <td>規格値の200%以下 Not more than 200% of the specified value.</td> </tr> <tr> <td>漏れ電流 Leakage Current</td> <td>規格値以下 Not more than the specified value.</td> </tr> </tbody> </table>		静電容量変化率 Capacitance Change	初期値の±20%以内 Within ±20% of the initial value.	損失角の正接 Dissipation Factor	規格値の200%以下 Not more than 200% of the specified value.	漏れ電流 Leakage Current	規格値以下 Not more than the specified value.																
静電容量変化率 Capacitance Change	初期値の±20%以内 Within ±20% of the initial value.																							
損失角の正接 Dissipation Factor	規格値の200%以下 Not more than 200% of the specified value.																							
漏れ電流 Leakage Current	規格値以下 Not more than the specified value.																							
準拠規格 Reference Standard	JIS C 5141																							

◆品番呼称方法 EXPLANATION OF PART NUMBER



◆サイズ記号 SIZE CODE

φD	22	25	30
L	A20	B20	C20

◆寸法図 DIMENSIONS

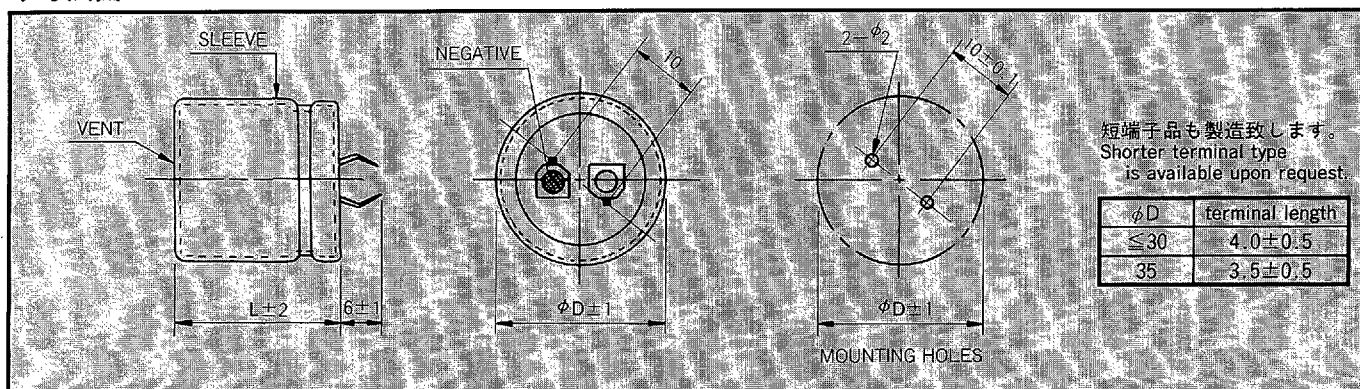



# 大形アルミニウム電解コンデンサ

LARGE CAN TYPE ALUMINUM ELECTROLYTIC CAPACITORS

MXF

◆寸法一覧表, 最大許容リップル電流一覧表 STANDARD SIZE, MAX. PERMISSIBLE RIPPLE CURRENT

Cap.( $\mu$ F)	10	16	25	35	50	63	80	100
330								22×20 0.60
390								25×20 0.71
470							22×20 0.65	25×20 0.78
560							22×20 0.70	30×20 0.95
680						22×20 0.83	25×20 0.84	30×20 1.09
820						25×20 0.99	30×20 1.04	30×20 1.32
1000					22×20 0.87	25×20 1.10	30×20 1.19	
1200					25×20 1.02	30×20 1.20	30×20 1.44	
1500				22×20 0.80	25×20 1.15	30×20 1.47		
1800				25×20 0.94	30×20 1.34	30×20 1.52		
2200			22×20 0.98	25×20 1.04	30×20 1.60			
2700			25×20 1.08	30×20 1.29				
3300		22×20 1.06	25×20 1.29	30×20 1.45				
3900		25×20 1.25	30×20 1.58					
4700	22×20 0.98	25×20 1.38	30×20 1.61					
5600	25×20 1.16	30×20 1.68						
6800	25×20 1.31	30×20 1.80						
8200	30×20 1.59							
10000	30×20 1.77							

大形電解コンデンサ  
LARGE CAN TYPE

Cap.( $\mu$ F)	160	180	200	250	315	350	400
33							22×20 0.25
39						22×20 0.27	25×20 0.28
47					22×20 0.28	25×20 0.31	25×20 0.31
56					25×20 0.34	25×20 0.34	30×20 0.36
68				22×20 0.39	25×20 0.39	30×20 0.40	30×20 0.40
82				22×20 0.45	30×20 0.45	30×20 0.45	
100		22×20 0.50	22×20 0.51	25×20 0.59	30×20 0.49		
120	22×20 0.53	22×20 0.54	22×20 0.56	25×20 0.62			
150	22×20 0.59	25×20 0.63	25×20 0.65	30×20 0.76			
180	25×20 0.70	25×20 0.70	30×20 0.78	30×20 0.79			
220	25×20 0.75	30×20 0.85	30×20 0.85				
270	30×20 0.95	30×20 0.95					
330	30×20 1.05						

↑ ↑  
リップル電流 Ripple Current A r.m.s./120Hz · 105°C  
ケースサイズ Case Size  $\phi D^1 \times L^{\pm 2}$  (mm)

◆リップル電流補正係数 MULTIPLIER FOR RIPPLE CURRENT  
周波数係数 Frequency coefficient

周波数 (Hz) Frequency	60	120	500	1k	10k $\leq$
10~100WV	0.90	1.00	1.05	1.10	1.15
160~250WV	0.80	1.00	1.10	1.14	1.18
315~400WV	0.80	1.00	1.05	1.10	1.15