

AN7351K, AN7351SC

Dual Pre-Amplifier ICs for Hi-Fi Cassette Deck

Overview

The AN7351K and the AN7351SC are the single chip ICs designed for pre-amp. for stereo cassette (double deck especially) incorporating 2-ch rec./playback/line amp. and muting/switching circuits.

Features

- Available for double deck
 1. Available for playback amp. tape speed switching
 2. Available for rec. amp. mute function
 3. Available for playback amp. input and output switching function
- Rec. amp. current and voltage both drive output is possible.
- Line amp. + mute circuit built-in
- Playback equalizer switching built-in
- Available for microcomputer direct drive of switching control pin

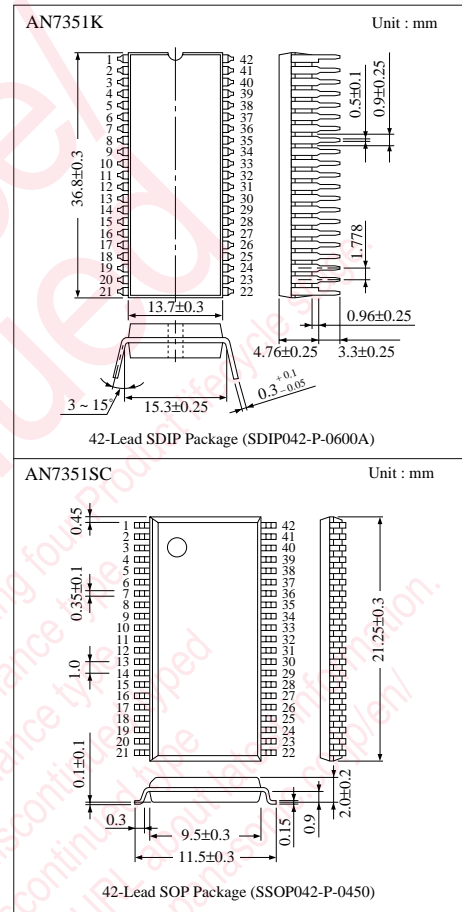

Block Diagram

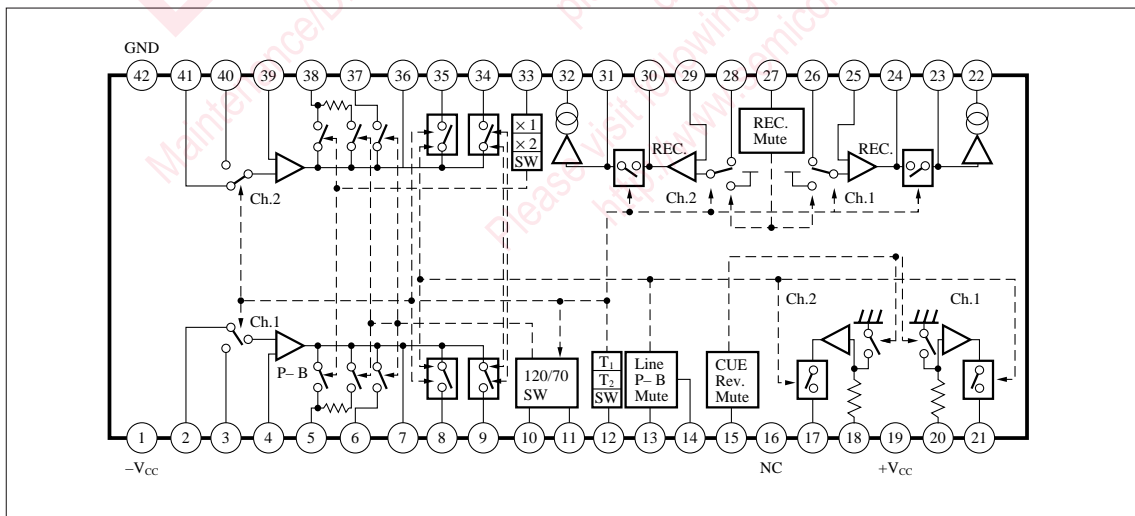

■ Absolute Maximum Ratings (Ta=25°C)

Parameter	Symbol	Rating	Unit
Supply Voltage	V _{CC}	±7.2	V
Supply Current	I _{CC}	39	mA
Power Dissipation	AN7351K	P _D	mW
	AN7351SC		
Operating Ambient Temperature	T _{opr}	-20 ~ + 75	°C
Storage Temperature	AN7351K	T _{stg}	°C
	AN7351SC		

* AN7351K : R_{th(j-a)}=123.3°C/W, AN7351SC : R_{th(j-a)}=127°C/W

■ Recommended Operating Range (Ta= 25°C)

Parameter	Symbol	Range
Operating Supply Voltage Range	V _{CC}	±4.5V ~ ±7V

■ Electrical Characteristics (V_{CC}= ±6V, f=1kHz, Ta=25°C)

Parameter	Symbol	Condition	min.	typ.	max.	Unit
<Playback Amp.> R _L =20kΩ						
Total Harmonic Distortion (1) Tape 1	THD (P1)	V _i =3.6mV Speed × 1 Feedback Time Constant 120μs	—	0.04	0.1	%
Total Harmonic Distortion (2) Tape 1	THD (P2)	V _i =3.6mV Speed × 1 Feedback Time Constant 70μs	—	0.04	0.1	%
Total Harmonic Distortion (3) Tape 2	THD (P3)	V _i =3.6mV Speed × 2 Feedback Time Constant 120μs	—	0.04	0.1	%
Total Harmonic Distortion (4) Tape 2	THD (P4)	V _i =3.6mV Speed × 2 Feedback Time Constant 70μs	—	0.04	0.1	%
Output Noise Voltage Tape 1	V _{N(T1)}	R _g =2.2kΩ, DIN/AUDIO, Speed × 1 Feedback Time Constant 120μs	—	0.7	1.5	mV
Output Noise Voltage Tape 2	V _{N(T2)}	R _g =2.2kΩ, DIN/AUDIO, Speed × 1 Feedback Time Constant 120μs	—	0.7	1.5	mV
Pulse Noise Voltage Tape 1	V _{PN(T1)}	R _g =2.2kΩ, DIN/AUDIO, Speed × 1 Feedback Time Constant 120μs	-0.9	—	9	mV _{P-O}
Pulse Noise Voltage Tape 2	V _{PN(T2)}	R _g =2.2kΩ, DIN/AUDIO, Speed × 1 Feedback Time Constant 120μs	-0.9	—	9	mV _{P-O}
Muting Attenuation Tape 1	R _{M(T1)}	V _i =3.6mV	60	—	—	dB
Muting Attenuation Tape 2	R _{M(T2)}	V _i =3.6mV	60	—	—	dB
Max. Output Voltage Tape 1	V _{O(T1)}	THD=3%	3	3.4	—	V
Max. Output Voltage Tape 2	V _{O(T2)}	THD=3%	3	3.4	—	V
Output Offset Voltage Tape 1	V _{DC(T1)}	R _g =220Ω	-70	—	70	mV
Output Offset Voltage Tape 2	V _{DC(T2)}	R _g =220Ω	-70	—	70	mV
Crosstalk Tape 1→Tape 2	CT (T1)	V _i =3.6mV	60	—	—	dB
Crosstalk Tape 2→Tape 1	CT (T2)	V _i =3.6mV	60	—	—	dB
<Rec. Amp>						
Total Harmonic Distortion VOL	THD (RV)	V _i =200mV	—	0.03	0.1	%
Total Harmonic Distortion CUR	THD (RC)	V _i =30mV	—	0.03	0.2	%
Max. Output Voltage VOL	V _{O(RV)}	THD=3%, R _L =10Ω	2.2	3.2	—	V
Max. Output Voltage CUR	V _{O(RC)}	THD=3%, R _L =1Ω	1	1.5	—	V
Muting Attenuation VOL	R _{M(RV)}	V _i =200mV	75	—	—	dB
Output Noise Voltage CUR	V _{N(RC)}	R _g =2.2kΩ, DIN/AUDIO	—	0.03	1	mV
Pulse Noise Voltage CUR	V _{PN(RC)}	R _g =2.2KΩ	-9	—	9	mV _{P-O}
Output Offset Current CUR	I _{DC(RC)}	R _g =5KΩ	-25	—	25	μA

Pin Descriptions

Pin No.	Pin Name	Typ. Waveform	Description	Equivalent Circuit
1	Negative Supply Pin	DC -6V	Main circuit -V _{CC}	
2	Playback Amp. T ₁ IN (Ch.1)	<p>DC 0V AC 3.6mV</p>	Playback amp. Tape1 input	
41	Playback Amp. T ₁ IN (Ch.2)			
3	Playback Amp. T ₂ IN (Ch.1)		Playback amp. Tape2 input	
40	Playback Amp. T ₂ IN (Ch.2)			
4	Playback Amp. NF IN (Ch.1)	DC 0V	Playback amp. negative feedback input	
39	Playback Amp. NF IN (Ch.2)			
5	120μs/70μs (×2) NF switch (Ch.1)	<p>DC 0V AC 1V</p>	Playback amp. Double-speed equalizer switching	
38	120μs/70μs (×2) NF switch (Ch.2)			
6	120μs/70μs (×1) NF switch (Ch.1)	<p>DC 0V AC 1V</p>	Playback amp. Normal speed equalizer switching	
37	120μs/70μs (×1) NF switch (Ch.2)			
7	Playback Amp. NF OUT (Ch.1)	<p>- DC 0V AC 1V</p>	Playback amp. negative feedback output	
36	Playback Amp. NF OUT (Ch.2)			
8	Playback Amp. T ₁ OUT (Ch.1)	<p>DC 0V AC 1V</p>	Playback amp. Tape 1 output	
35	Playback Amp. T ₁ OUT (Ch.2)			
9	Playback Amp. T ₂ OUT (Ch.1)		Playback amp. Tape 2 output	
34	Playback Amp. T ₂ OUT (Ch.2)			

■ Pin Descriptions (Cont.)

Pin No.	Pin Name	Typ. Waveform	Description	Equivalent Circuit
10	T ₂ (120μs/70μs) LOGIC	_____	Tape 2 equalizer switching 70μs – Open 120μs – Low (less than 1.5V)	
11	T ₁ (120μs/70μs) LOGIC	_____	Tape 1 equalizer switching 70μs – Open 120μs – Low (less than 1.5V)	
12	T ₁ /T ₂ LOGIC	_____	Tape 1 and Tape 2 switching T ₁ – Open T ₂ – Low (less than 1.5V)	
13	LINE/PB Amp. Mute LOGIC	_____	Line amp., PB amp. mute switching Mute ON – Open Mute OFF – Low (less than 1.6V)	
14	LINE Mute TIMING	_____	Line mute soft switching	
15	CUE/REV Mute LOGIC	_____	Mute ON – Open Mute OFF – Low (less than 1.6V)	
16	NC	_____	_____	_____
17	LINE Mute Amp. OUT (Ch.2)	DC 0V 	Line amp. output	
21	LINE Mute Amp. OUT (Ch.1)	AC 1V		

■ Pin Descriptions (Cont.)

Pin No.	Pin Name	Typ. Waveform	Description	Equivalent Circuit
18	LINE Mute Amp. IN (Ch.2)	DC 0V	Line amp. input	
20	LINE Mute Amp. IN (Ch.1)	AC 1V		
19	Supply Pin	DC 6V	Main circuit + V _{CC}	
22	REC. Amp. Current Out (Ch.1)	DC 0V	Rec. amp. current output 200mV output at input 30mV, load 100kΩ	
32	REC. Amp. Current Out (Ch.2)	AC 1V		
23	REC. Amp. Voltage Out (Ch.1)	DC 0V	Rec. amp. voltage output 1.45V output at input 200mV	
31	REC. Amp. Voltage Out (Ch.2)	AC 1V		
24	REC. Amp. NF OUT (Ch.1)	DC 0V	Rec. amp. feedback output	
30	REC. Amp. NF OUT (Ch.2)	AC 1V		
25	REC. Amp. NF IN (Ch.1)	DC 0V	Rec. amp. negative feedback input	
29	REC. Amp. NF IN (Ch.2)			
26	REC. Amp. IN (Ch.1)	DC 0V	Rec. amp. input	
28	REC. Amp. IN (Ch.2)	AC 1V		

■ Pin Descriptions (Cont.)

Pin No.	Pin Name	Typ. Waveform	Description	Equivalent Circuit
27	REC. Mute LOGIC	————	Rec. amp. mute switching Mute ON – Open Mute OFF – Low (less than 1.6V)	
33	SPEED H/L LOGIC	————	Speed H/L switching × 1 – Open × 2 – Low (less than 1.2V)	
42	GND	DC 0V	Main Circuit GND	————

Request for your special attention and precautions in using the technical information and semiconductors described in this book

- (1) If any of the products or technical information described in this book is to be exported or provided to non-residents, the laws and regulations of the exporting country, especially, those with regard to security export control, must be observed.
- (2) The technical information described in this book is intended only to show the main characteristics and application circuit examples of the products, and no license is granted under any intellectual property right or other right owned by our company or any other company. Therefore, no responsibility is assumed by our company as to the infringement upon any such right owned by any other company which may arise as a result of the use of technical information described in this book.
- (3) The products described in this book are intended to be used for standard applications or general electronic equipment (such as office equipment, communications equipment, measuring instruments and household appliances).
Consult our sales staff in advance for information on the following applications:
 - Special applications (such as for airplanes, aerospace, automobiles, traffic control equipment, combustion equipment, life support systems and safety devices) in which exceptional quality and reliability are required, or if the failure or malfunction of the products may directly jeopardize life or harm the human body.
 - Any applications other than the standard applications intended.
- (4) The products and product specifications described in this book are subject to change without notice for modification and/or improvement. At the final stage of your design, purchasing, or use of the products, therefore, ask for the most up-to-date Product Standards in advance to make sure that the latest specifications satisfy your requirements.
- (5) When designing your equipment, comply with the range of absolute maximum rating and the guaranteed operating conditions (operating power supply voltage and operating environment etc.). Especially, please be careful not to exceed the range of absolute maximum rating on the transient state, such as power-on, power-off and mode-switching. Otherwise, we will not be liable for any defect which may arise later in your equipment.
 - Even when the products are used within the guaranteed values, take into the consideration of incidence of break down and failure mode, possible to occur to semiconductor products. Measures on the systems such as redundant design, arresting the spread of fire or preventing glitch are recommended in order to prevent physical injury, fire, social damages, for example, by using the products.
- (6) Comply with the instructions for use in order to prevent breakdown and characteristics change due to external factors (ESD, EOS, thermal stress and mechanical stress) at the time of handling, mounting or at customer's process. When using products for which damp-proof packing is required, satisfy the conditions, such as shelf life and the elapsed time since first opening the packages.
- (7) This book may be not reprinted or reproduced whether wholly or partially, without the prior written permission of Matsushita Electric Industrial Co., Ltd.