

**FEATURES**

- **40dB of electrical gain**
- **1.0 to 1.6 VDC supply operating range**
- **current trim capability ( $R_T$ )**
- **high efficiency class B output stage**
- **may be used with a linear or compression preamplifier**

**STANDARD PACKAGING**

- 8 pin MICROpac (unavailable for LD549)
- 8 pin MINIpac
- 8 pin PLID®
- Chip (47 x 40 mils)

**DESCRIPTION**

The LC/LV/LD549 is an 8 pin, low voltage, push-pull audio frequency output stage amplifier with a single unbalanced input. The circuit utilizes two internal negative feedback loops to stabilize the DC operating point for temperature stability and to linearize the transfer function over a wide dynamic range. The circuit operates near ideal class B conditions resulting in low distortion and very low quiescent current, required for extended battery life.

The LC549, LV549 and LD549 differ in only one respect; the LV549 and LD549 are selected devices which are capable of delivering from 10 mA to 41 mA and from 36 mA to 75 mA of output current respectively. These values are the maximum current drawn with both output stage transistors in saturation. Thus the LD549 is capable of producing a high output in a low impedance load, the LV549 is selected to have lower peak currents, extending the life of the battery.

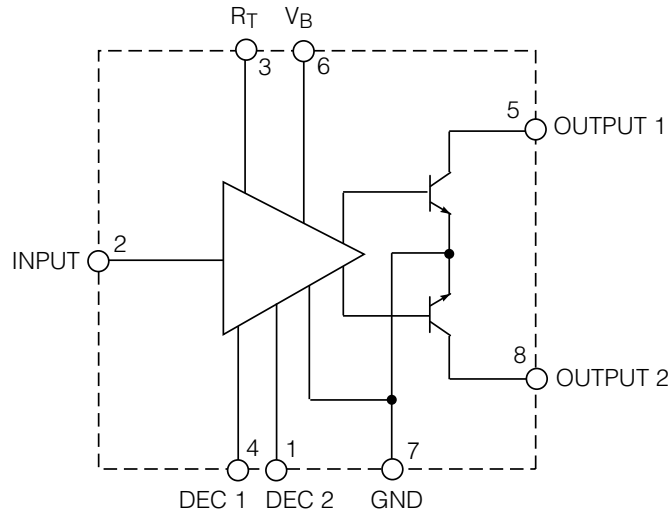

U.S. Patent No. 4,085,382  
Patented in other countries

**BLOCK DIAGRAM**

## ABSOLUTE MAXIMUM RATINGS

| PARAMETER             | VALUE & UNITS  |
|-----------------------|----------------|
| Supply Voltage        | 3 VDC          |
| Power dissipation     | 60 mW          |
| Operating Temperature | -10 to + 40 °C |
| Storage Temperature   | -20 to + 70 °C |

**CAUTION**  
CLASS 1 ESD SENSITIVITY



## PIN CONNECTION

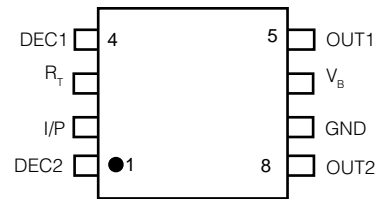

## ELECTRICAL CHARACTERISTICS

Conditions: Temperature 25 °C, Supply Voltage  $V_B = 1.3$  VDC

| PARAMETER                         | SYMBOL      | CONDITION                                  | MIN | TYP | MAX | UNITS      |
|-----------------------------------|-------------|--|-----|-----|-----|------------|
| Gain                              | $A_{CL}$    | $V_{OUT} = 0.707$ VRMS                     | 38  | 40  | 42  | dB         |
| Quiescent Current                 | $I_{AMP}$   |  | 100 | -   | 400 | $\mu$ A    |
|                                   | $I_{TRANS}$ |  | 170 | -   | 370 | $\mu$ A    |
|                                   | $I_{TOT}$   |  | -   | 500 | 770 | $\mu$ A    |
| Maximum Drive Current             |             | $V1 = 0V$ (S2, S3 closed)                  |     |     |     |            |
|                                   |             | $V4 = 0V$ LC549                            | 10  | 35  | 75  | mA         |
|                                   |             | LV549                                      | 10  | -   | 41  | mA         |
|                                   |             | LD549                                      | 36  | 50  | 75  | mA         |
| Input Impedance                   |             |  | 18  | 27  | 36  | k $\Omega$ |
| Total Harmonic Distortion & Noise | THD         | $V_{OUT} = 0.707$ VRMS                     | -   | 0.5 | -   | %          |
|                                   |             | $V_{OUT} = 1.3$ VRMS                       | -   | 2.5 | 5.2 | %          |
| Input Referred Noise              | IRN         | NFB 0.2 to 10 kHz at 12 dB/oct (S1 closed) | -   | 1.2 | 2.5 | $\mu$ V    |
| Start Up Time                     |             |  | -   | -   | 3   | sec        |

All switches and parameters remain as shown in test circuit unless stated in condition column

### START-UP TIME TEST (Refer to Test Circuit)

|   | SEQUENCE  | CONDITIONS | COMMENTS  |
|---|---|------------|---|
| 1 | Power Supply  | Off        |   |
| 2 | S1  | Closed     | Removes $V_{IN}$  |
| 3 | S2 / S3   | Closed     | Discharges C2 and C3  |
| 4 | S1  | Open       | Applies $V_{IN}$ ( $V_{IN}$ level is determined from Gain Test) |
| 5 | S2 / S3   | Open       | Removes short from C2 and C3                                    |
| 6 | Power Supply  | On         |   |
| 7 | Gain must be within specification, within 3 seconds after power supply is turned on |            |   |

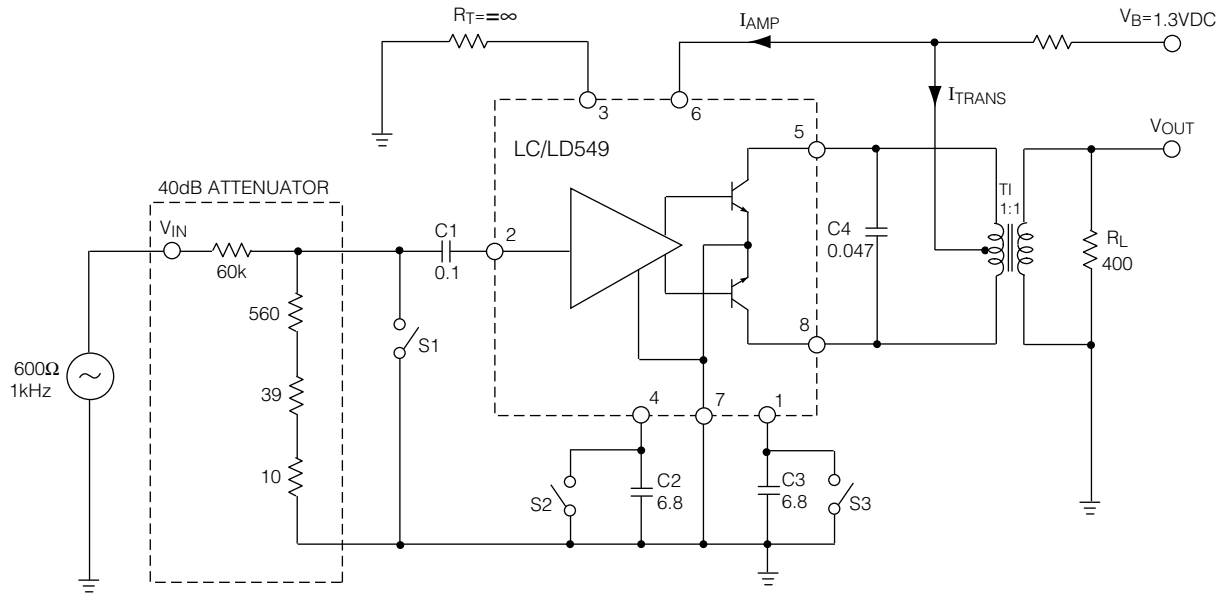

All resistors in ohms, all capacitors in  $\mu\text{F}$  unless otherwise stated

$$\text{Gain} = 20 \text{Log}_{10} \left( \frac{V_{\text{OUT}}}{V_{\text{IN}}} \right) + 40 \text{ dB}$$

Fig. 1 Test Circuit

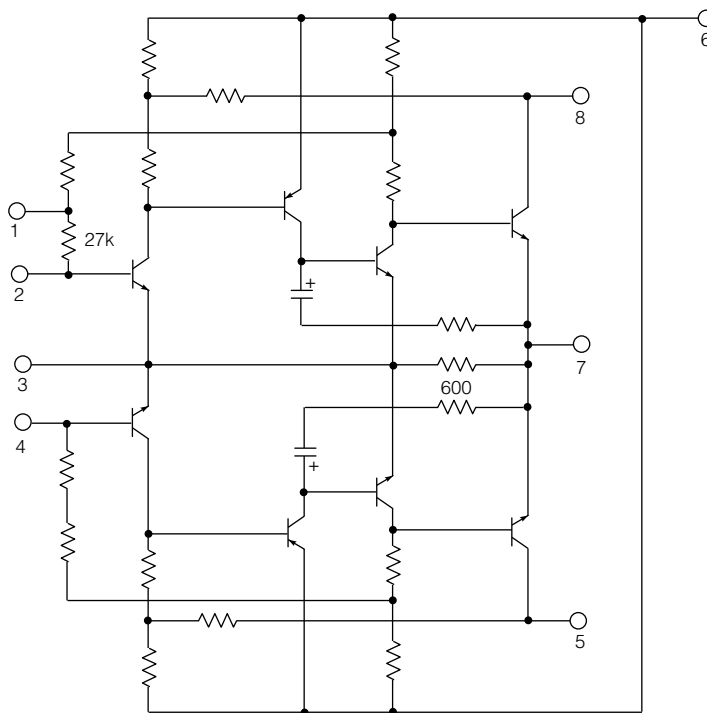

All resistors in ohms, all capacitors in farads unless otherwise stated  
U.S. Patent No. 4,085,382 - Patented in other countries

Fig. 2 Equivalent Circuit

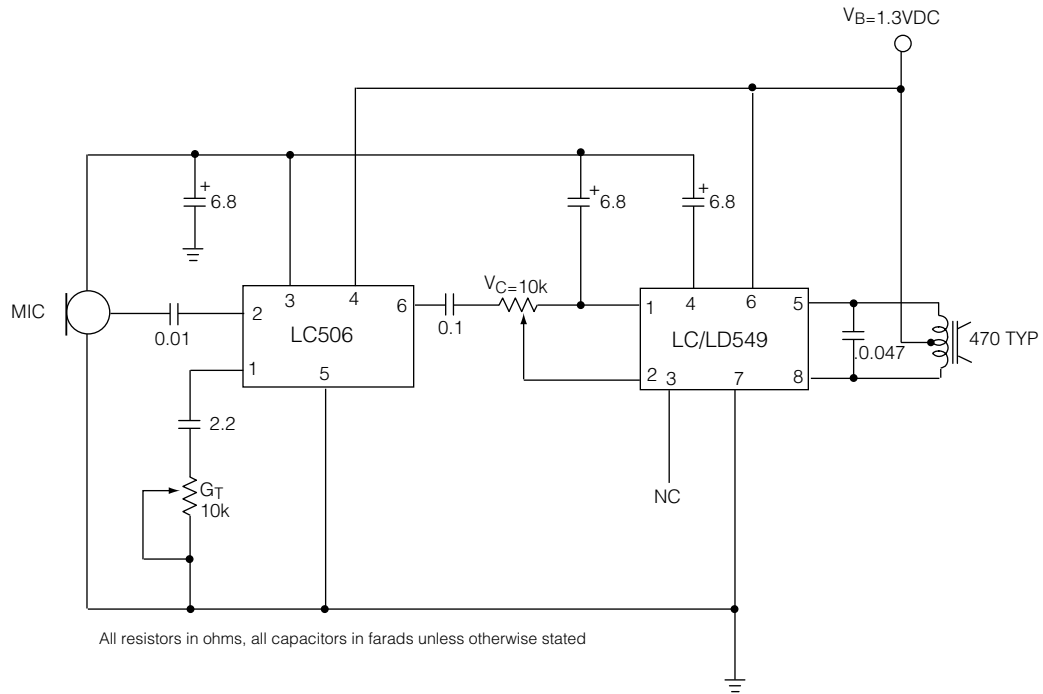

Fig. 3 Typical Hearing Aid Circuit

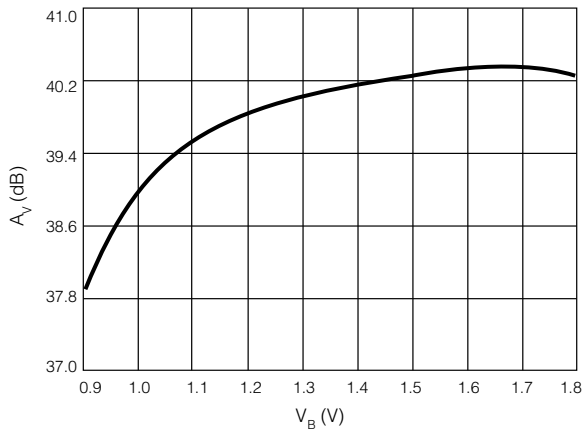

Fig. 4 Volume Gain vs Battery Voltage

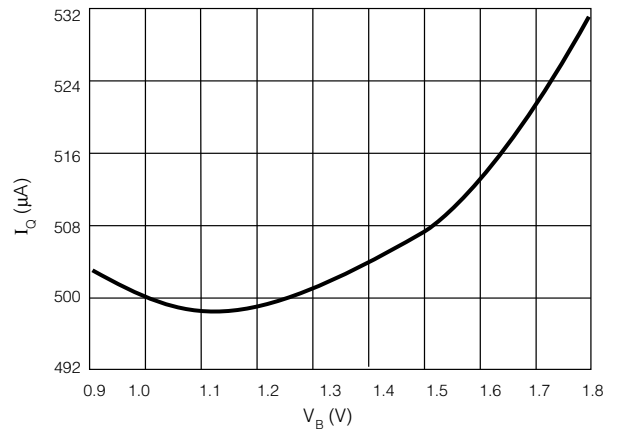

Fig. 5 Quiescent Current vs Battery Voltage

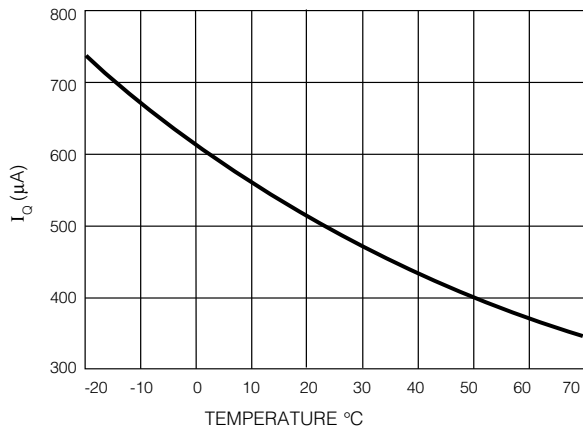

Fig. 6 Quiescent Current vs Temperature

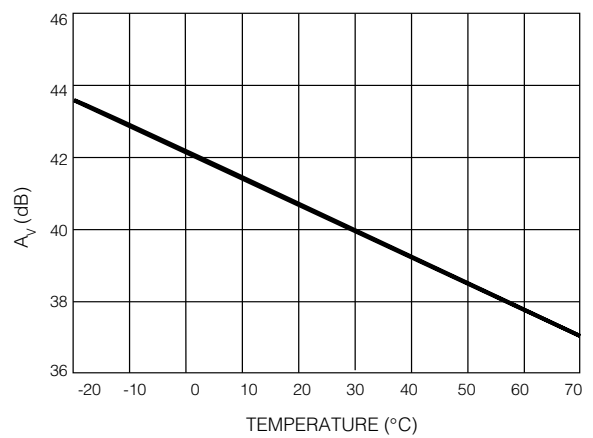

Fig. 7 Gain vs Temperature

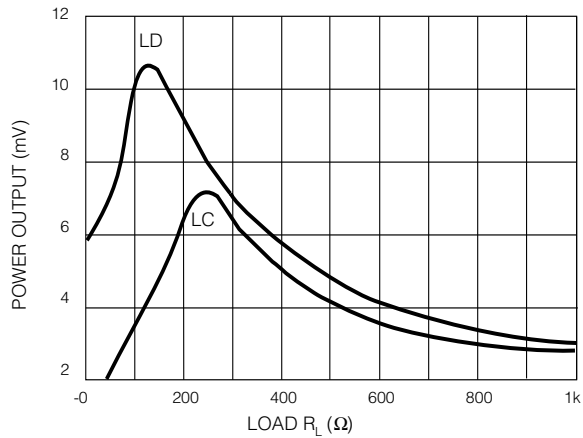

Fig. 8 Power Output vs Load Resistance at 7% Distortion  $R_B = 0\Omega$

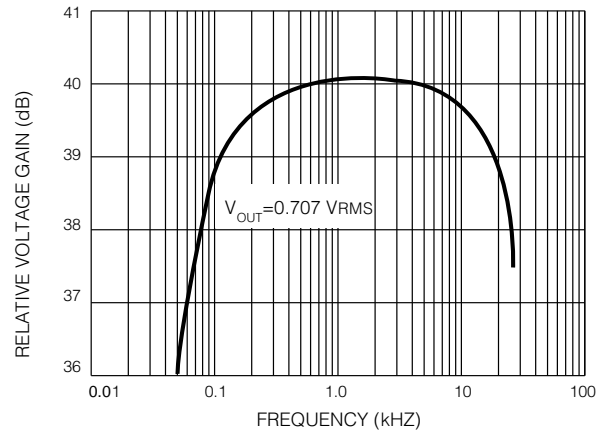

Fig. 9 Voltage Gain vs Frequency

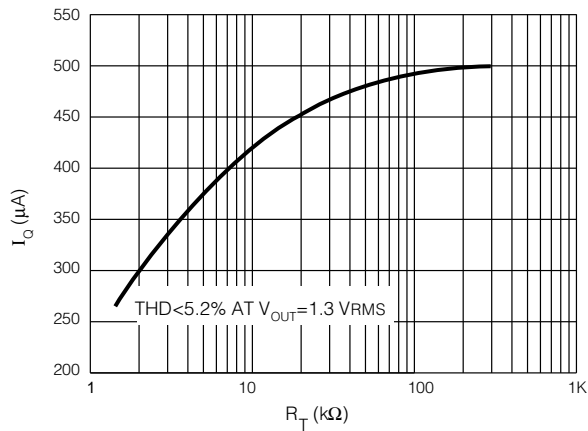

Fig. 10 Quiescent Current vs Current Trim Resistor

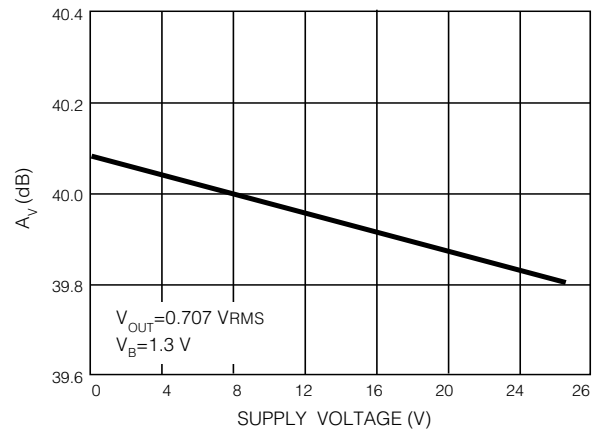

Fig. 11 Voltage Gain vs Battery Resistance

**REVISION NOTES**  
8 pin MICROpac unavailable for LD549

**DOCUMENT IDENTIFICATION**

**PRODUCT PROPOSAL**

This data has been compiled for market investigation purposes only, and does not constitute an offer for sale.

**ADVANCE INFORMATION NOTE**

The product is in a development phase and specifications are subject to change without notice. Gennum reserves the right to remove the product at any time. Listing the product does not constitute an offer for sale.

**PRELIMINARY DATA SHEET**

The product is in preproduction phase and specifications are subject to change without notice.

**DATA SHEET**

The product is in production. Gennum reserves the right to make changes at any time to improve reliability, function or design, in order to provide the best product possible.