



# PI74FCT322501T PI74FCT322Q501T

## Fast CMOS 36-Bit Registered Transceiver with 3-State Outputs

### Product Features:

#### Common Features:

- $V_{CC} = 5V \pm 10\%$
- Hysteresis on all inputs
- Bus Hold retains last active bus state during tri-state
- Internal resistors eliminates the need for external pullup resistors
- Packages available:
  - 100-pin TQFP (F100)

#### PI74FCT322501T Features:

- Balanced output drivers:  $\pm 24$  mA

#### PI74FCT322Q501T Features:

- Balanced output drivers:  $\pm 12$  mA
- Output impedance:  $35\Omega$  (typical)

### Product Description:

Pericom Semiconductor's PI74FCT series of logic circuits are produced in the Company's advanced 0.6 micron CMOS technology, achieving industry leading speed grades.

The PI74FCT322501T and PI74FCT322Q501T are 36-bit registered bus transceivers designed with D-type latches and flip-flops to allow data flow in transparent, latched, and clocked modes. The Output Enable ( $xOEAB$  and  $xOEBA$ ), Latch Enable ( $xLEAB$  and  $xLEBA$ ) and Clock ( $xCLKAB$  and  $xCLKBA$ ) inputs control the data flow in each direction.

When  $xLEAB$  is HIGH, the device operates in transparent mode for A-to-B data flow. When  $xLEAB$  is LOW, the A data is latched if  $xCLKAB$  is held at a HIGH or LOW logic level. When  $xLEAB$  is LOW, the A bus data is stored in the latch/flip-flop on the transition of  $xCLKAB$ . Data flow from B port to A port is similar to that of A port to B port but uses  $xOEBA$ ,  $xLEBA$  and  $xCLKBA$ .

Internal  $50K\Omega$  pullup and pulldown resistors are provided for the two Output Enable inputs.  $xOEAB$  should be tied to GND through a pulldown resistor. Its minimum value is determined by the current-sourcing capability of the driver. The Output Enables are complementary ( $xOEAB$  is active HIGH and  $xOEBA$  is active LOW).

The PI74FCT322501T and PI74FCT322Q501T have "Bus Hold" which retains the input's last state whenever the input goes to high-impedance preventing "floating" inputs and eliminating the need for pullup/down resistors.

The PI74FCT322501T and PI74FCT322Q501T are designed with current limiting resistors at its outputs to control the output edge rate resulting in lower ground bounce and undershoot.

The PI74FCT322Q501T also features an additional internal series resistor which further minimizes noise. This virtually eliminates the need for any external terminating resistors for most low noise bus interface applications. This noise suppression benefit is designated by the letter "Q" (for quiet) in the part number.

### Truth Table<sup>(1,4)</sup>

Inputs				Outputs
$xOEAB$	$xLEAB$	$xCLKAB$	$A_x$	$B_x$
L	X	X	X	Z
H	H	X	L	L
H	H	X	H	H
H	L	$\uparrow$	L	L
H	L	$\uparrow$	H	H
H	L	H	X	$B^{(2)}$
H	L	L	X	$B^{(3)}$

#### Notes:

1. A-to-B data flow is shown. B-to-A data flow is similar but uses  $xOEBA$ ,  $xLEBA$ , and  $xCLKBA$ .
2. Output level before the indicated steady-state input conditions were established.
3. Output level before the indicated steady-state input conditions were established, provided that  $xCLKAB$  was LOW before  $xLEAB$  went LOW.
4. H = High Voltage Level  
L = Low Voltage Level  
Z = High Impedance  
 $\uparrow$  = LOW-to-HIGH Transition

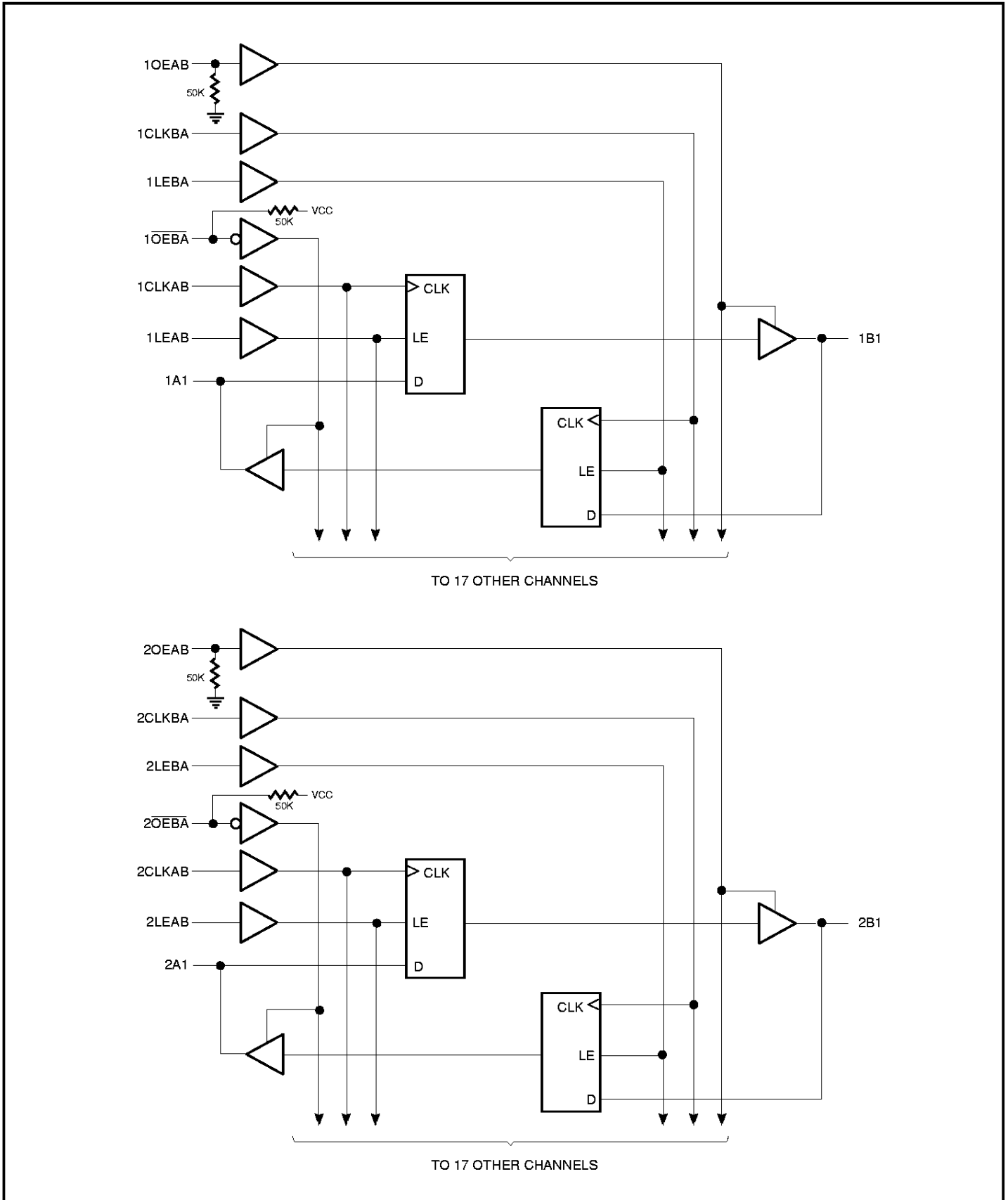
**Logic Block Diagram**

### Product Pin Configuration

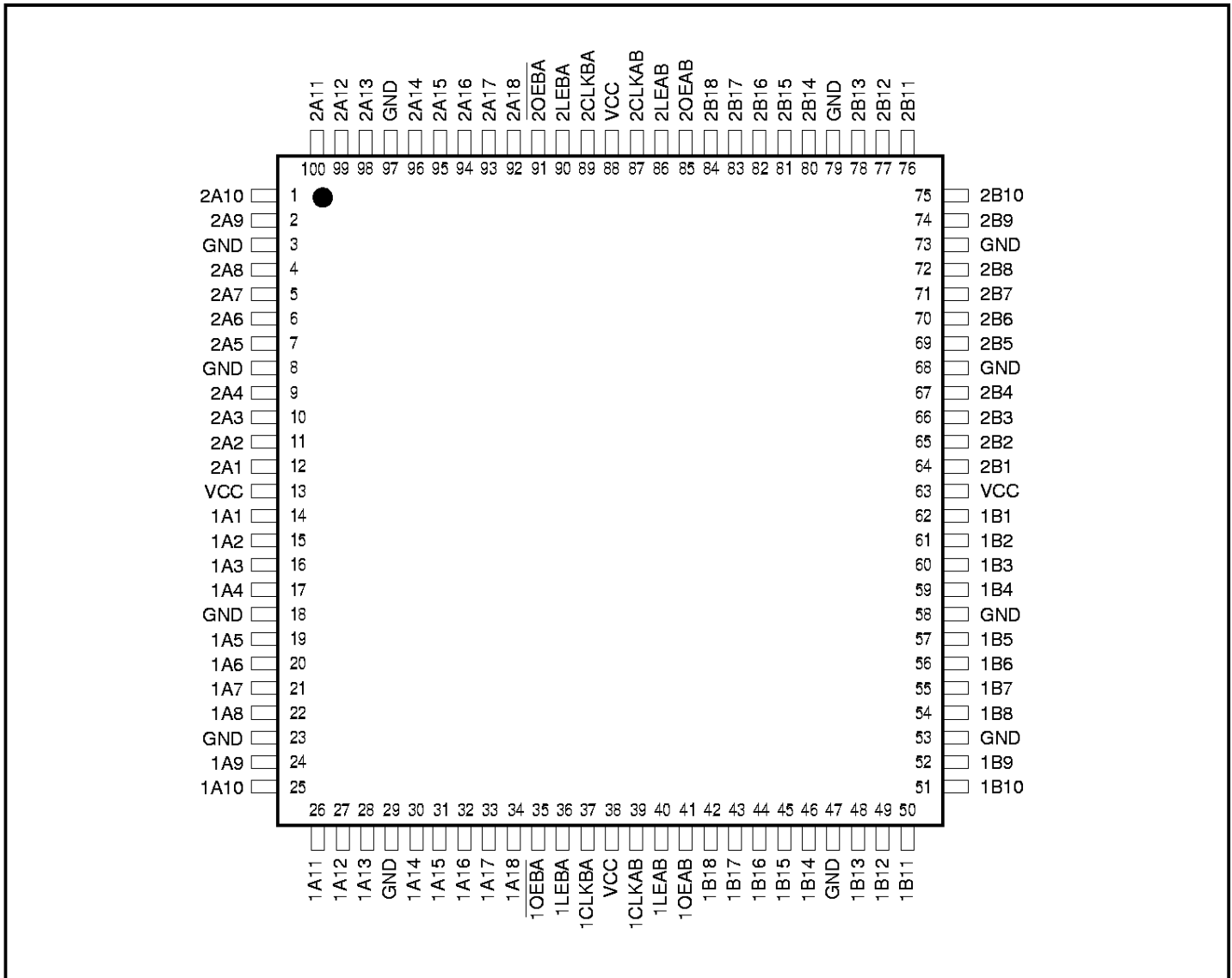

### Product Pin Description

Pin Name	Description
xOEAB	A-to-B Output Enable Inputs (Active HIGH)
xOEBA	B-to-A Output Enable Inputs (Active LOW)
xLEAB	A-to-B Latch Enable Inputs
xLEBA	B-to-A Latch Enable Inputs
xCLKAB	A-to-B Clock Inputs
xCLKBA	B-to-A Clock Inputs
xAx	A-to-B Data Inputs or B-to-A 3-State Outputs
xBx	B-to-A Data Inputs or A-to-B 3-State Outputs
GND	Ground
Vcc	Power

### Maximum Ratings

(Above which the useful life may be impaired. For user guidelines, not tested.)

Storage Temperature .....	-55°C to +125°C
Ambient Temperature with Power Applied .....	-40°C to +85°C
Supply Voltage to Ground Potential (Inputs & Vcc Only) .....	-0.5V to +7.0V
Supply Voltage to Ground Potential (Outputs & D/O Only) .....	-0.5V to +7.0V
DC Input Voltage .....	-0.5V to +7.0V
DC Output Current .....	120 mA
Power Dissipation .....	1.2W

#### Note:

Stresses greater than those listed under **MAXIMUM RATINGS** may cause permanent damage to the device. This is a stress rating only and functional operation of the device at these or any other conditions above those indicated in the operational sections of this specification is not implied. Exposure to absolute maximum rating conditions for extended periods may affect reliability.

### DC Electrical Characteristics (Over the Operating Range, TA = -40°C to +85°C, VCC = 5.0V ± 10%)

Parameters	Description	Test Conditions <sup>(1)</sup>		Min.	Typ <sup>(2)</sup>	Max.	Units
V <sub>IH</sub>	Input HIGH Voltage	Guaranteed Logic HIGH Level		2.0			V
V <sub>IL</sub>	Input LOW Voltage	Guaranteed Logic LOW Level				0.8	V
I <sub>IH</sub>	Input HIGH Current	Standard Input, V <sub>CC</sub> = Max.	V <sub>IN</sub> = V <sub>CC</sub>			1	μA
I <sub>IH</sub>	Input HIGH Current	Standard I/O, V <sub>CC</sub> = Max.	V <sub>IN</sub> = V <sub>CC</sub>			1	μA
I <sub>IH</sub>	Input HIGH Current	Bus Hold Input <sup>(4)</sup> , V <sub>CC</sub> = Max.	V <sub>IN</sub> = V <sub>CC</sub>			±100	μA
I <sub>IH</sub>	Input HIGH Current	Bus Hold I/O <sup>(4)</sup> , V <sub>CC</sub> = Max.	V <sub>IN</sub> = V <sub>CC</sub>			±100	μA
I <sub>IL</sub>	Input LOW Current	Standard Input, V <sub>CC</sub> = Min.	V <sub>IN</sub> = GND			-1	μA
I <sub>IL</sub>	Input LOW Current	Standard I/O, V <sub>CC</sub> = Min.	V <sub>IN</sub> = GND			-1	μA
I <sub>IL</sub>	Input LOW Current	Bus Hold Input <sup>(4)</sup> , V <sub>CC</sub> = Min.	V <sub>IN</sub> = GND			±100	μA
I <sub>IL</sub>	Input LOW Current	Bus Hold I/O <sup>(4)</sup> , V <sub>CC</sub> = Min.	V <sub>IN</sub> = GND			±100	μA
I <sub>BHH</sub>	Bus Hold	Bus Hold Input <sup>(4)</sup> , V <sub>CC</sub> = Min.	V <sub>IN</sub> = 2.0V	-50			μA
I <sub>BHL</sub>	Sustain Current		V <sub>IN</sub> = 0.8V	+50			
I <sub>BHHO</sub>	Bus Hold	Bus Hold Input <sup>(4)</sup> , V <sub>CC</sub> = Max.	V <sub>IN</sub> = 1.5V			TBD	mA
I <sub>BHLO</sub>	Overdrive Current						
I <sub>OZH</sub>	High-Impedance	V <sub>CC</sub> = Max.	V <sub>OUT</sub> = 2.7V			1	μA
I <sub>OZL</sub>	Output Current (3-State Outputs)	V <sub>CC</sub> = Max.	V <sub>OUT</sub> = 0.5V			-1	μA
V <sub>IK</sub>	Clamp Diode Voltage	V <sub>CC</sub> = Min., I <sub>IN</sub> = -18 mA			-0.7	-1.2	V
I <sub>OS</sub>	Short Circuit Current	V <sub>CC</sub> = Max. <sup>(3)</sup> , V <sub>OUT</sub> = GND		-80	-140	-200	mA
I <sub>O</sub>	Output Drive Current	V <sub>CC</sub> = Max. <sup>(3)</sup> , V <sub>OUT</sub> = 2.5V		-50		-180	mA
V <sub>H</sub>	Input Hysteresis				100		mV

#### Notes:

1. For Max. or Min. conditions, use appropriate value specified under Electrical Characteristics for the applicable device type.
2. Typical values are at V<sub>CC</sub> = 5.0V, +25°C ambient and maximum loading.
3. Not more than one output should be shorted at one time. Duration of the test should not exceed one second.
4. Pins with Bus Hold are identified in the pin description.

**PI74FCT322501T Output Drive Characteristics (Over the Operating Range)**

Parameters	Description	Test Conditions <sup>(1)</sup>		Min.	Typ <sup>(2)</sup>	Max.	Units
V <sub>OH</sub>	Output HIGH Voltage	V <sub>CC</sub> = Min., V <sub>IN</sub> = V <sub>IH</sub> or V <sub>IL</sub>	I <sub>OH</sub> = -24.0 mA	2.4	3.3	—	V
V <sub>OL</sub>	Output LOW Voltage	V <sub>CC</sub> = Min., V <sub>IN</sub> = V <sub>IH</sub> or V <sub>IL</sub>	I <sub>OL</sub> = 24 mA	—	0.3	0.55	V
I <sub>ODL</sub>	Output LOW Current	V <sub>CC</sub> = 5V, V <sub>IN</sub> = V <sub>IH</sub> or V <sub>IL</sub> , V <sub>OUT</sub> = 1.5V <sup>(3)</sup>		60	115	150	mA
I <sub>ODH</sub>	Output HIGH Current	V <sub>CC</sub> = 5V, V <sub>IN</sub> = V <sub>IH</sub> or V <sub>IL</sub> , V <sub>OUT</sub> = 1.5V <sup>(3)</sup>		-60	-115	-150	mA

**PI74FCT322Q501T Output Drive Characteristics (Over the Operating Range)**

Parameters	Description	Test Conditions <sup>(1)</sup>		Min.	Typ <sup>(2)</sup>	Max.	Units
V <sub>OH</sub>	Output HIGH Voltage	V <sub>CC</sub> = Min., V <sub>IN</sub> = V <sub>IH</sub> or V <sub>IL</sub>	I <sub>OH</sub> = -12.0 mA	2.4	3.3	—	V
V <sub>OL</sub>	Output LOW Voltage	V <sub>CC</sub> = Min., V <sub>IN</sub> = V <sub>IH</sub> or V <sub>IL</sub>	I <sub>OL</sub> = 12 mA	—	0.3	0.55	V
I <sub>ODL</sub>	Output LOW Current	V <sub>CC</sub> = 5V, V <sub>IN</sub> = V <sub>IH</sub> or V <sub>IL</sub> , V <sub>OUT</sub> = 1.5V <sup>(3)</sup>		—	TBD	—	mA
I <sub>ODH</sub>	Output HIGH Current	V <sub>CC</sub> = 5V, V <sub>IN</sub> = V <sub>IH</sub> or V <sub>IL</sub> , V <sub>OUT</sub> = 1.5V <sup>(3)</sup>		—	TBD	—	mA

**Capacitance (T<sub>A</sub> = 25°C, f = 1 MHz)**

Parameters <sup>(4)</sup>	Description	Test Conditions	Typ.	Max.	Units
C <sub>IN</sub>	Input Capacitance	V <sub>IN</sub> = 0V	4.5	6	pF
C <sub>OUT</sub>	Output Capacitance	V <sub>OUT</sub> = 0V	5.5	8	pF

**Notes:**

1. For Max. or Min. conditions, use appropriate value specified under Electrical Characteristics for the applicable device type.
2. Typical values are at V<sub>CC</sub> = 5.0V, +25°C ambient and maximum loading.
3. Not more than one output should be shorted at one time. Duration of the test should not exceed one second.
4. This parameter is determined by device characterization but is not production tested.

**Power Supply Characteristics**

Parameters	Description	Test Conditions <sup>(1)</sup>		Min.	Typ <sup>(2)</sup>	Max.	Units
I <sub>CC</sub>	Quiescent Power Supply Current	V <sub>CC</sub> = Max.	V <sub>IN</sub> = GND or V <sub>CC</sub>		0.2	20	μA
ΔI <sub>CC</sub>	Supply Current per Input @ TTL HIGH	V <sub>CC</sub> = Max.	V <sub>IN</sub> = 3.4V <sup>(3)</sup>		1.0	6.0	mA
I <sub>CCD</sub>	Supply Current per Input per MHz <sup>(4)</sup>	V <sub>CC</sub> = Max., Outputs Open OEAB = OEBA = V <sub>CC</sub> or GND One Bit Toggling 50% Duty Cycle	V <sub>IN</sub> = V <sub>CC</sub> V <sub>IN</sub> = GND		150	240	μA/ MHz

**Notes:**

1. For Max. or Min. conditions, use appropriate value specified under Electrical Characteristics for the applicable device.
2. Typical values are at V<sub>CC</sub> = 5.0V, +25°C ambient.
3. Per TTL driven input (V<sub>IN</sub> = 3.4V); all other inputs at V<sub>CC</sub> or GND.
4. This parameter is not directly testable, but is derived for use in Total Power Supply Calculations.

**PI74FCT322501/322Q501T Switching Characteristics over Operating Range**

Parameters	Description	Conditions <sup>(1)</sup>	322501/Q501AT		322501/Q501CT		322501/Q501DT		322501/Q501ET		Unit
			Com.		Com.		Com.		Com.		
			Min	Max	Min	Max	Min	Max	Min	Max	
t <sub>PLH</sub> t <sub>PHL</sub>	Propagation Delay Ax to Bx or Ax to Bx	C <sub>L</sub> = 50 pF R <sub>L</sub> = 500Ω	1.5	5.1	1.5	4.6	1.5	4.1	1.5	3.8	ns
t <sub>PLH</sub> t <sub>PHL</sub>	Propagation Delay xLEBA to Ax, xLEAB to Bx		1.5	5.6	1.5	5.3	1.5	4.6	1.5	4.2	ns
t <sub>PLH</sub> t <sub>PHL</sub>	Propagation Delay xCLKBA to Ax, CLKAB to Bx		1.5	5.6	1.5	5.3	1.5	4.6	1.5	4.2	ns
t <sub>PZH</sub> t <sub>PZL</sub>	Output Enable Time xOEBA to Ax, xOEAB to Bx		1.5	6.0	1.5	5.6	1.5	5.2	1.5	4.8	ns
t <sub>PHZ</sub> t <sub>PLZ</sub>	Output Disable Time <sup>(3)</sup> xOEBA to Ax, xOEAB to Bx		1.5	5.6	1.5	5.2	1.5	5.2	1.5	5.2	ns
t <sub>SU</sub>	Setup Time HIGH or LOW Ax to xCLKAB, Bx to xCLKBA		3.0	—	3.0	—	3.0	—	2.4	—	ns
t <sub>H</sub>	Hold Time HIGH or LOW Ax to xCLKAB, Bx to xCLKBA		0	—	0	—	0	—	0	—	ns
t <sub>SU</sub>	Setup Time HIGH or LOW Ax to xLEAB, Bx to xLEBA	Clock HIGH	3.0	—	3.0	—	3.0	—	2.0	—	ns
		Clock LOW	1.5	—	1.5	—	1.5	—	1.5	—	ns
t <sub>H</sub>	Hold Time HIGH or LOW Ax to xLEAB, Bx to xLEBA		1.5	—	1.5	—	1.5	—	0.5	—	ns
t <sub>w</sub>	xLEAB or xLEBA Pulse Width HIGH <sup>(3)</sup>		3.0	—	3.0	—	3.0	—	3.0	—	ns
t <sub>w</sub>	xCLKAB or xCLKBA Pulse Width HIGH or LOW <sup>(3)</sup>		3.0	—	3.0	—	3.0	—	3.0	—	ns
t <sub>SK(o)</sub>	Output Skew <sup>(4)</sup>		—	0.5	—	0.5	—	0.5	—	0.5	ns

**Notes:**

1. See test circuit and wave forms.
2. Minimum limits are guaranteed but not tested on Propagation Delays.
3. This parameter is guaranteed but not production tested.
4. Skew between any two outputs, of the same package, switching in the same direction. This parameter is guaranteed by design.