

## 74147 Encoder

10-Line-To-4-Line Priority Encoder  
Product Specification

### Logic Products

#### FEATURES

- Encodes 10-line decimal to 4-line BCD
- Useful for 10-position switch encoding
- Used in code converters and generators

#### DESCRIPTION

The '147 9-input priority encoder accepts data from nine active-LOW inputs ( $I_1 - I_9$ ) and provides a binary representation on the four active-LOW outputs ( $A_0 - A_3$ ). A priority is assigned to each input so that when two or more inputs are simultaneously active, the input with the highest priority is represented on the output, with input line  $I_9$  having the highest priority.

The device provides the 10-line-to-4-line priority encoding function by use of the implied decimal "zero." The "zero" is encoded when all nine data inputs are HIGH, forcing all four outputs HIGH.

TYPE	TYPICAL PROPAGATION DELAY	TYPICAL SUPPLY CURRENT (TOTAL)
74147	10ns	46mA

#### ORDERING CODE

PACKAGES	COMMERCIAL RANGE $V_{CC} = 5V \pm 5\%$ ; $T_A = 0^\circ C$ to $+70^\circ C$
Plastic DIP	N74147N

#### NOTE:

For information regarding devices processed to Military Specifications see the Signetics Military Products Data Manual.

#### INPUT AND OUTPUT LOADING AND FAN-OUT TABLE

PINS	DESCRIPTION	74
All	Inputs	1ul
All	Outputs	10ul

#### NOTE:

A 74 unit load (ul) is understood to be  $40\mu A I_{IH}$  and  $-1.6mA I_{IL}$ .

#### PIN CONFIGURATION

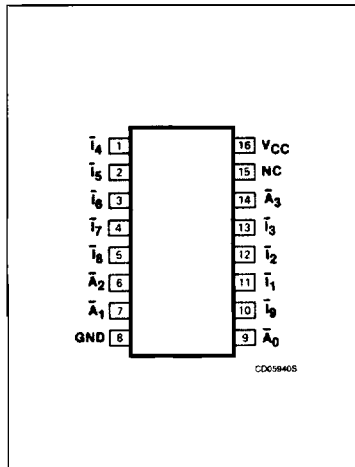

#### LOGIC SYMBOL

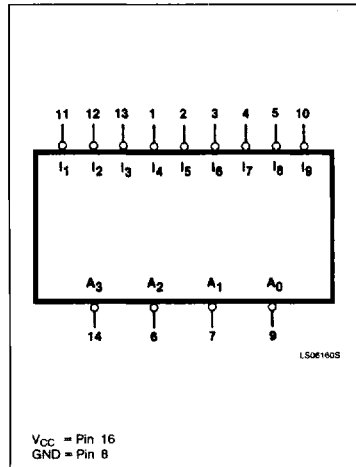

#### LOGIC SYMBOL (IEEE/IEC)

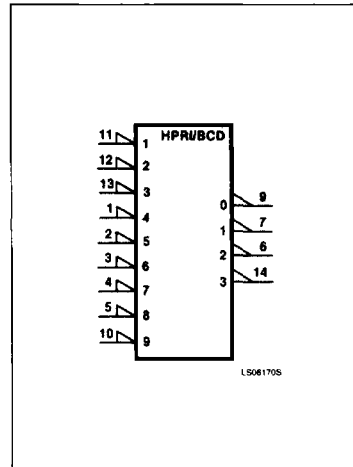

# Encoder

74147

## LOGIC DIAGRAM

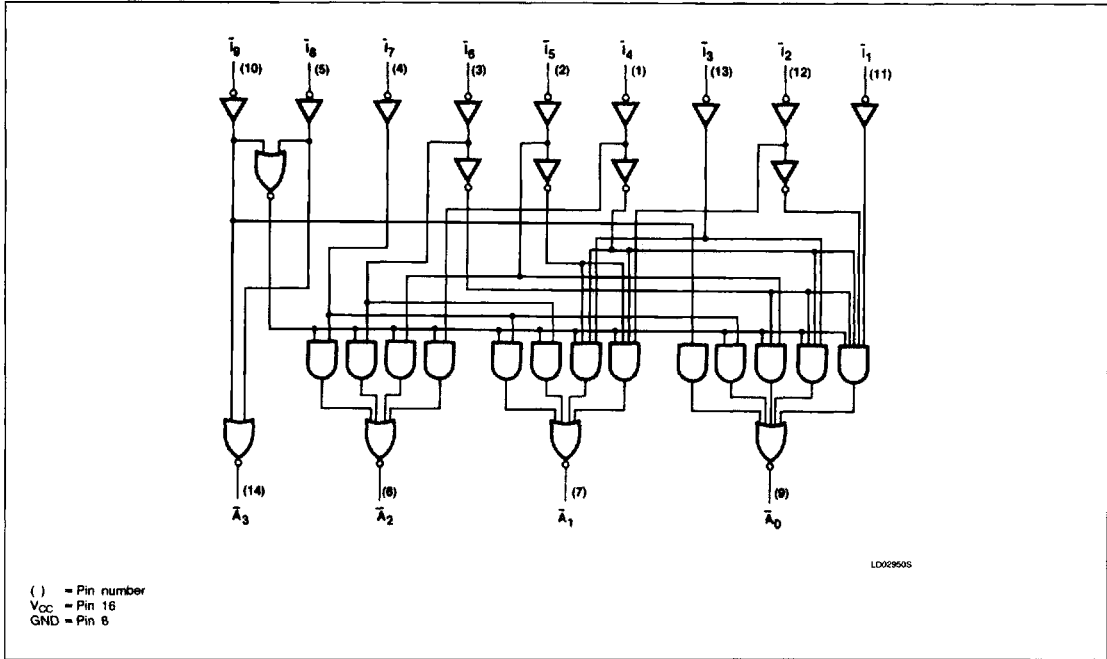

## FUNCTION TABLE

INPUTS									OUTPUTS			
$\bar{i}_1$	$\bar{i}_2$	$\bar{i}_3$	$\bar{i}_4$	$\bar{i}_5$	$\bar{i}_6$	$\bar{i}_7$	$\bar{i}_8$	$\bar{i}_9$	$\bar{A}_3$	$\bar{A}_2$	$\bar{A}_1$	$\bar{A}_0$
H	H	H	H	H	H	H	H	H	H	H	H	H
X	X	X	X	X	X	X	X	L	L	H	H	L
X	X	X	X	X	X	X	L	H	L	H	H	L
X	X	X	X	X	L	H	H	H	H	L	L	H
X	X	X	X	L	H	H	H	H	H	L	H	L
X	X	L	H	H	H	H	H	H	H	H	L	L
X	L	H	H	H	H	H	H	H	H	H	L	H
L	H	H	H	H	H	H	H	H	H	H	H	L

H = HIGH voltage level  
 L = LOW voltage level  
 X = Don't care

## Encoder

74147

**ABSOLUTE MAXIMUM RATINGS** (Over operating free-air temperature range unless otherwise noted.)

PARAMETER		74	UNIT
V <sub>CC</sub>	Supply voltage	7.0	V
V <sub>IN</sub>	Input voltage	-0.5 to +5.5	V
I <sub>IN</sub>	Input current	-30 to +5	mA
V <sub>OUT</sub>	Voltage applied to output in HIGH output state	-0.5 to +V <sub>CC</sub>	V
T <sub>A</sub>	Operating free-air temperature range	0 to 70	°C

**RECOMMENDED OPERATING CONDITIONS**

PARAMETER	74			UNIT	
	Min	Nom	Max		
V <sub>CC</sub>	Supply voltage	4.75	5.0	5.25	V
V <sub>IH</sub>	HIGH-level input voltage	2.0			V
V <sub>IL</sub>	LOW-level input voltage			+0.8	V
I <sub>IK</sub>	Input clamp current			-12	mA
I <sub>OH</sub>	HIGH-level output current			-800	μA
I <sub>OL</sub>	LOW-level output current			16	mA
T <sub>A</sub>	Operating free-air temperature	0		70	°C

5

**DC ELECTRICAL CHARACTERISTICS** (Over recommended operating free-air temperature range unless otherwise noted.)

PARAMETER	TEST CONDITIONS <sup>1</sup>	74147			UNIT		
		Min	Typ <sup>2</sup>	Max			
V <sub>OH</sub>	HIGH-level output voltage	V <sub>CC</sub> = MIN, V <sub>IH</sub> = MIN, V <sub>IL</sub> = MAX, I <sub>OH</sub> = MAX		2.4	3.3		V
V <sub>OL</sub>	LOW-level output voltage	V <sub>CC</sub> = MIN, V <sub>IH</sub> = MIN, V <sub>IL</sub> = MAX, I <sub>OL</sub> = MAX			0.2	0.4	V
V <sub>IK</sub>	Input clamp voltage	V <sub>CC</sub> = MIN, I <sub>I</sub> = I <sub>IK</sub>				-1.5	V
I <sub>I</sub>	Input current at maximum input voltage	V <sub>CC</sub> = MAX, V <sub>I</sub> = 5.5V				1.0	mA
I <sub>IH</sub>	HIGH-level input current	V <sub>CC</sub> = MAX, V <sub>I</sub> = 2.4V				40	μA
I <sub>IL</sub>	LOW-level input current	V <sub>CC</sub> = MAX, V <sub>I</sub> = 0.4V				-1.6	mA
I <sub>OS</sub>	Short-circuit output current <sup>3</sup>	V <sub>CC</sub> = MAX		-35		-85	mA
I <sub>CC</sub>	Supply current <sup>4</sup> (total)	V <sub>CC</sub> = MAX	Condition 1		50	70	mA
			Condition 2		42	62	mA

**NOTES:**

- For conditions shown as MIN or MAX, use the appropriate value specified under recommended operating conditions for the applicable type.
- All typical values are at V<sub>CC</sub> = 5V, T<sub>A</sub> = 25°C.
- I<sub>OS</sub> is tested with V<sub>OUT</sub> = +0.5V and V<sub>CC</sub> = V<sub>CC</sub> MAX + 0.5V. Not more than one output should be shorted at a time and duration of the short circuit should not exceed one second.
- Condition 1: Measure I<sub>CC</sub> with I<sub>7</sub> grounded, other inputs and outputs open. Condition 2: Measure I<sub>CC</sub> with all inputs and outputs open.

# Encoder

74147

## AC WAVEFORMS

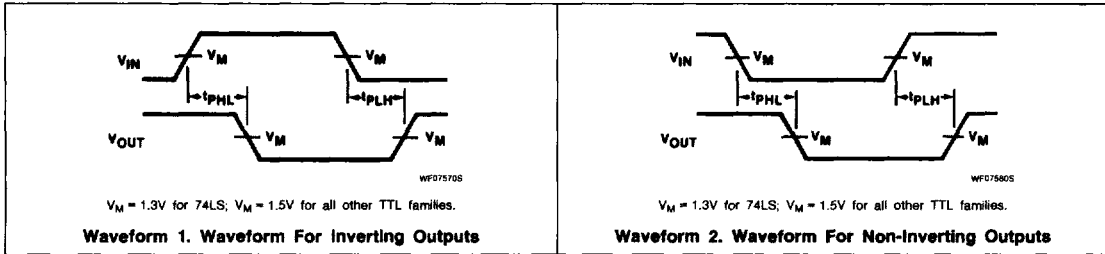

## AC ELECTRICAL CHARACTERISTICS $T_A = 25^\circ C, V_{CC} = 5.0V$

PARAMETER	TEST CONDITIONS	74		UNIT
		$C_L = 15pF, R_L = 400\Omega$		
		Min	Max	
$t_{PLH}$ $t_{PHL}$	Propagation delay Out-of-phase output	Waveform 1	19	ns
		Waveform 2	19	
$t_{PLH}$ $t_{PHL}$	Propagation delay In-phase output	Waveform 2	14	ns
			11	

## TEST CIRCUITS AND WAVEFORMS

