

8-Bit μ p-compatible D/A converter

NE/SE5018/5019

DESCRIPTION

The NE/SE5018/19 is a complete 8-bit digital-to-analog converter subsystem on one monolithic chip. The data inputs have input latches which are controlled by a latch enable pin. The data and latch enable inputs are ultra-low loading for easy interfacing with all logic systems. The latches appear transparent when the \overline{LE} input is in the low state. When \overline{LE} goes high, the input data present at the moment of transition is latched and retained until \overline{LE} again goes low. This feature allows easy compatibility with most microprocessors.

The chip also comprises a stable voltage reference (5V nominal) and high slew rate buffer amplifier. The voltage reference may be externally trimmed with a potentiometer for easy adjustment of full-scale while maintaining a low temperature coefficient.

The output of the buffer amplifier may be offset so as to provide bipolar as well as unipolar operation.

FEATURES

- 8-bit resolution
- Input latches
- Low-loading data inputs
- On-chip voltage reference
- Output buffer amplifier
- Accurate to \pm LSB (0.19%)
- Monotonic to 8 bits
- Amplifier and reference both short-circuit protected
- Compatible with 8085, 6800 and many other μ Ps

APPLICATIONS

- Precision 8-bit D/A converters
- A/D converters
- Programmable power supplies
- Test equipment
- Measuring instruments
- Analog-digital multiplication

ORDERING INFORMATION

DESCRIPTION	TEMPERATURE RANGE	ORDER CODE	DWG #
22-Pin Ceramic Dual In-Line Package (CERDIP)	0 to +70°C	NE5018/5019F	0585B
22-Pin Ceramic Dual In-Line Package (CERDIP)	-55°C to +125°C	SE5018/5019F	0585B
22-Pin Plastic Dual In-Line Package (DIP)	0 to +70°C	NE5018/5019N	0409B
22-Pin Plastic Dual In-Line Package (DIP)	-55°C to +125°C	SE5018/5019N	0409B
24-Pin Small Outline Large (SOL) Package	0 to +70°C	NE5018/5019D	0173D

PIN CONFIGURATIONS

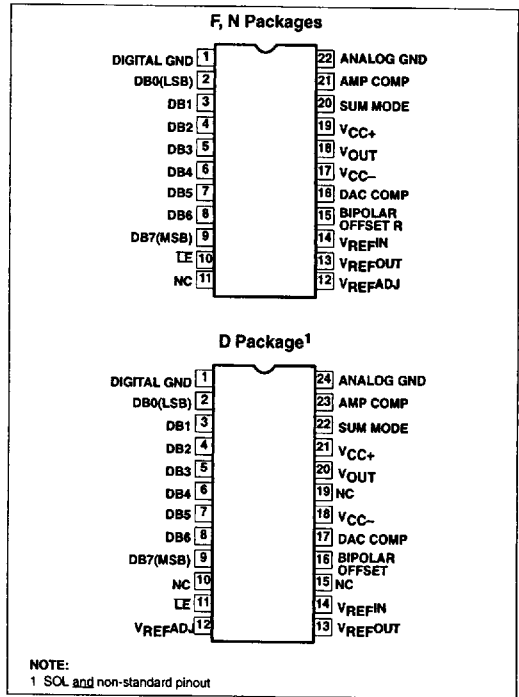

8-Bit μ P-compatible D/A converter

NE/SE5018/5019

BLOCK DIAGRAM

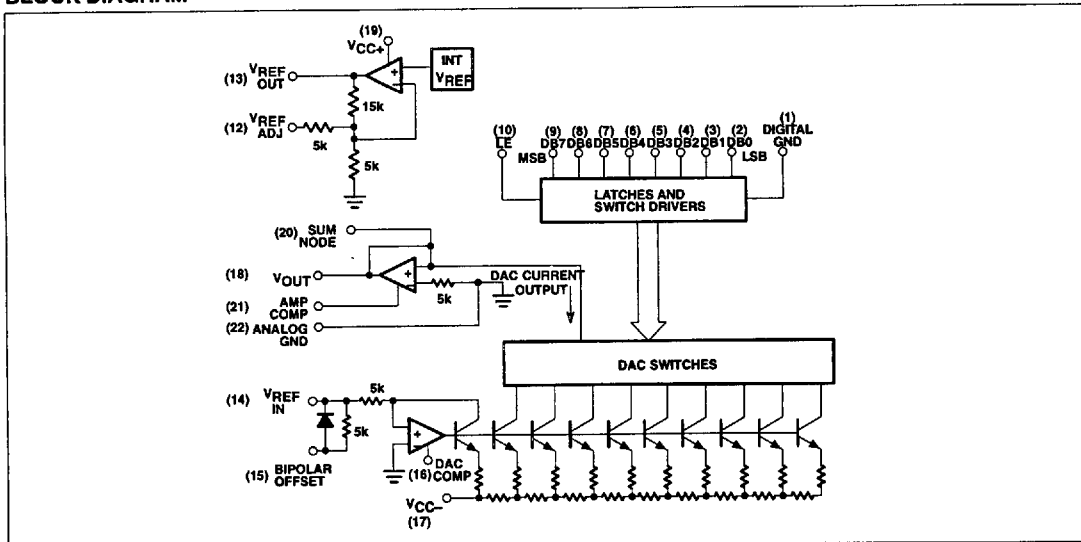

ABSOLUTE MAXIMUM RATINGS

SYMBOL	PARAMETER	RATING	UNIT
V_{CC+}	Positive supply voltage	18	V
V_{CC-}	Negative supply voltage	-18	V
V_{IN}	Logic input voltage	0 to 18	V
$V_{REF\ IN}$	Voltage at V_{REF} input	12	V
$V_{REF\ ADJ}$	Voltage at V_{REF} adjust	0 to V_{REF}	V
V_{SUM}	Voltage at sum node	12	V
$I_{REF\ SC}$	Short-circuit current to ground at $V_{REF\ OUT}$	Continuous	
I_{OUTSC}	Short-circuit current to ground or either supply at V_{OUT}	Continuous	
P_D	Maximum power dissipation, $T_A=25^\circ\text{C}$ (still-air) ¹		
	F package	1740	mW
	N package	2190	mW
	D package	1600	mW
T_A	Operating temperature range		
	SE5018	-55 to +125	$^\circ\text{C}$
	NE5018	0 to +70	$^\circ\text{C}$
T_{STG}	Storage temperature range	-65 to +150	$^\circ\text{C}$
T_{SOLD}	Lead soldering temperature (10 seconds)	300	$^\circ\text{C}$

NOTES:

- Derate above 25°C at the following rates:
 F package at $13.9\text{mW}/^\circ\text{C}$
 N package at $17.5\text{mW}/^\circ\text{C}$
 D package at $12.8\text{mW}/^\circ\text{C}$

8-Bit μ p-compatible D/A converter

NE/SE5018/5019

DC ELECTRICAL CHARACTERISTICS

$V_{CC+}=+15V$, $V_{CC-}=-15V$, SE5018. $-55^{\circ}C \leq T_A \leq 125^{\circ}C$, NE5018. $0^{\circ}C \leq T_A \leq 70^{\circ}C$, unless otherwise specified. [†] Typical values are specified at $25^{\circ}C$.

SYMBOL	PARAMETER	TEST CONDITIONS	NE/SE5018			NE/SE5019			UNIT
			Min	Typ	Max	Min	Typ	Max	
	Resolution		8	8	8	8	8	8	Bits
	Monotonicity		8	8	8	8	8	8	Bits
	Relative accuracy				± 0.19			± 0.1	%FS
V_{CC+}	Positive supply voltage		11.4	15		11.4	15		V
V_{CC-}	Negative supply voltage		-11.4	-15		-11.4	-15		V
$V_{IN(1)}$	Logic "1" input voltage	Pin 1=0V	2.0			2.0			V
$V_{IN(0)}$	Logic "0" input voltage	Pin 1=0V			0.8			0.8	V
$I_{IN(1)}$	Logic "1" input current	Pin 1=0V, $2V < V_{IN} < 18V$		0.1	10		0.1	10	μ A
$I_{IN(0)}$	Logic "0" input current	Pin 1=0V, $-5V < V_{IN} < 0.8V$		-2.0	-10		-2.0	-10	μ A
V_{FS}	Full-scale output	Unipolar mode, $V_{REF}=5.000V$, all bits high, $T_A=25^{\circ}C$	9.50		10.5	9.50		10.5	V
$+V_{FS}$	Full-scale output	Bipolar mode, $V_{REF}=5.000V$ all bits high, $T_A=25^{\circ}C$	4.75		5.25	4.75		5.25	V
$-V_{FS}$	Negative full scale	Bipolar mode, $V_{REF}=5.000V$, all bits low, $T_A=25^{\circ}C$	-5.25		-4.75	-5.25		-4.75	V
V_{ZS}	Zero-scale Output	Unipolar mode, $V_{REF}=5.000V$ all bits low, $T_A=25^{\circ}C$	-30		+30	-30		+30	mV
I_{OS}	Output short circuit current	$T_A=25^{\circ}C$ $V_{OUT}=0V$		15	40		15	40	mA
$PSR^{+}(OUT)$	Output power supply rejection (+)	$V_{-}=-15V$, $13.5V \leq V_{+} \leq 16.5V$, external $V_{REF IN}=5.000V$		0.001	0.01		0.001	0.01	%FS %VS
$PSR^{-}(OUT)$	Output power supply rejection (-)	$V_{+}=-15V$, $-13.5V \leq V_{-} \leq -16.5V$, external $V_{REF IN}=5.000V$		0.001	0.01		0.001	0.01	%FS %VS
TC_{FS}	Full-scale temperature coefficient	$V_{REF IN}=5.000V$		20			20		ppm/ $^{\circ}C$
TC_{ZS}	Zero-scale temperature coefficient			5			5		ppm/ $^{\circ}C$
I_{REF}	Reference output current				3			3	mA
I_{REFSC}	Reference short circuit current	$T_A=25^{\circ}C$ $V_{REF OUT}=0V$		15	30		15	30	mA
$PSR^{+}(REF)$	Reference power supply rejection (+)	$V_{-}=-15V$, $13.5V \leq V_{+} \leq 16.5V$, $I_{REF}=1.0mA$		0.003	0.01		0.003	0.01	%VR/%VS
$PSR^{-}(REF)$	Reference power supply rejection (-)	$V_{+}=-15V$, $-13.5V \leq V_{-} \leq -16.5V$, $I_{REF}=1.0mA$		0.003	0.01		0.003	0.01	%VR/%VS
V_{REF}	Reference voltage	$I_{REF}=1.0mA$ $T_A=25^{\circ}C$	4.9	5.0	5.25	4.9	5.0	5.25	V
TC_{REF}	Reference voltage temperature coefficient	$I_{REF}=1.0mA$		60			60		ppm/ $^{\circ}C$
Z_{IN}	DAC $V_{REF IN}$ input impedance	$I_{REF}=1.0mA$, $T_A=25^{\circ}C$	4.15	5.0	5.85	4.15	5.0	5.85	k Ω
I_{CC+}	Positive supply current	$V_{CC+}=15V$		7	14		7	14	mA
I_{CC-}	Negative supply current	$V_{CC-}=-15V$		-10	-15		-10	-15	mA
P_D	Power dissipation	$I_{REF}=1.0mA$, $V_{CC}=\pm 15V$		255	435		255	435	mW

NOTES:

1. Refer to Figure 1.

8-Bit μ P-compatible D/A converter

NE/SE5018/5019

AC ELECTRICAL CHARACTERISTICS¹

$V_{CC} = \pm 15V, T_A = 25^\circ C$

SYMBOL	PARAMETER	TO	FROM	TEST CONDITIONS	NE/SE5018/19			UNIT
					Min	Typ	Max	
t_{SLH}	Settling time	$\pm 1/2LSB$	Input	All bits low-to-high ²		1.8		μs
t_{SHL}	Settling time	$\pm 1/2LSB$	Input	All bits high-to-low ³		2.3		μs
t_{PLH}	Propagation delay	Output	Input	All bits switched low-to-high ²		300		ns
t_{PHL}	Propagation delay	Output	Input	All bits switched high-to-low ³		150		ns
t_{PLSB}	Propagation delay	Output	Input	1 LSB change ^{2, 3}		150		ns
t_{PLH}	Propagation delay	Output	\overline{LE}	Low-to-high transition ⁴		300		ns
t_{PHL}	Propagation delay	Output	\overline{LE}	High-to-low transition ⁵		150		ns
t_S	Setup time	\overline{LE}	Input	1, 6	100			ns
t_H	Hold time	Input	\overline{LE}	1, 6	50			ns
t_{PW}	Latch enable pulse width			1, 6	150			ns

NOTES:

1. Refer to Figure 2.
2. See Figure 5.
3. See Figure 6.
4. See Figure 7.
5. See Figure 8.
6. See Figure 9.
7. For reference currents > 3mA, use of an external buffer is required.

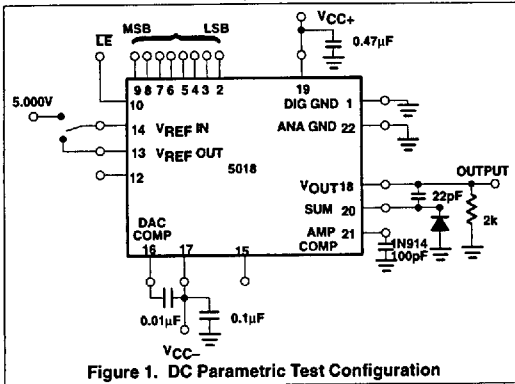

Figure 1. DC Parametric Test Configuration

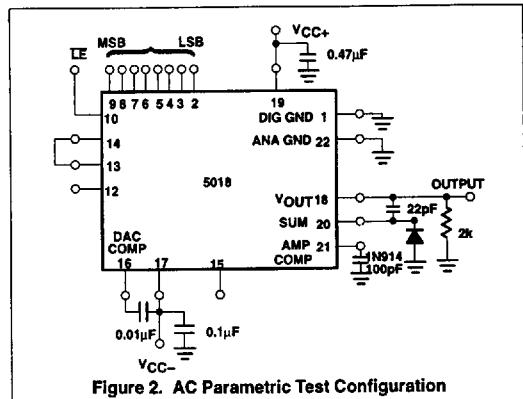

Figure 2. AC Parametric Test Configuration

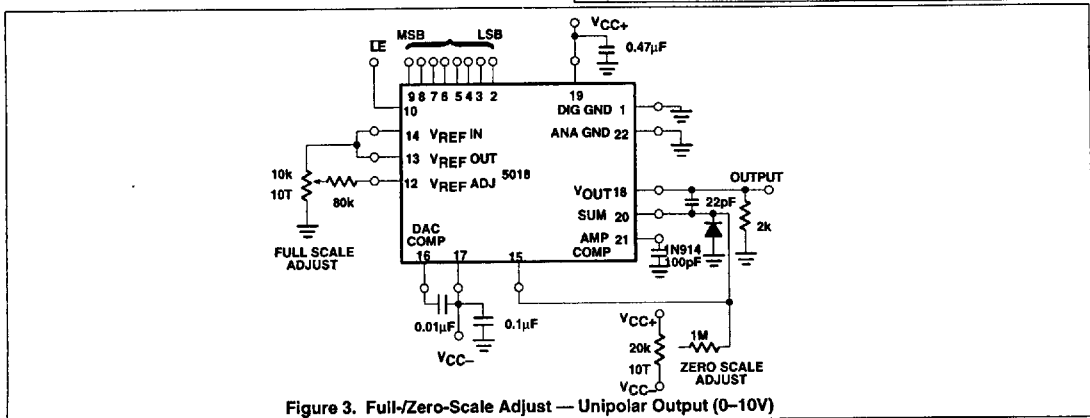

Figure 3. Full/Zero-Scale Adjust — Unipolar Output (0-10V)

8-Bit μ p-compatible D/A converter

NE/SE5018/5019

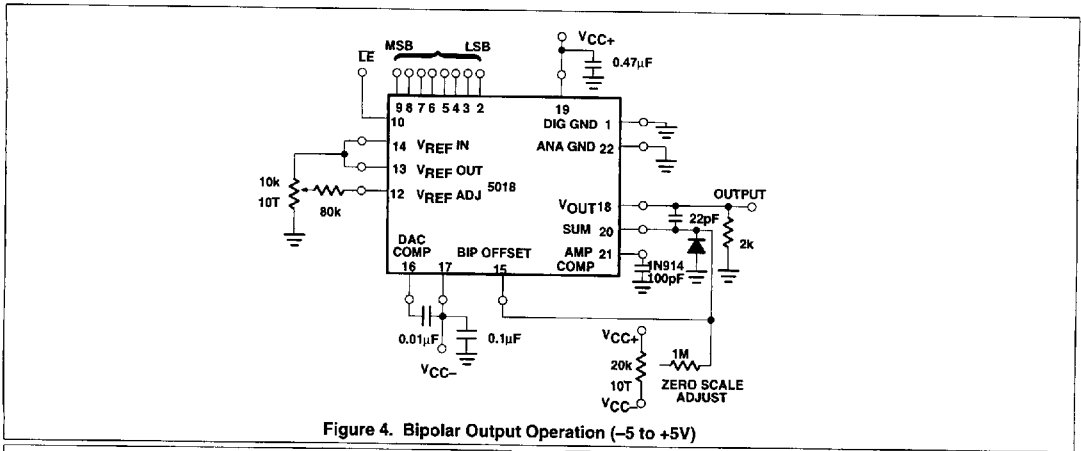

Figure 4. Bipolar Output Operation (-5 to +5V)

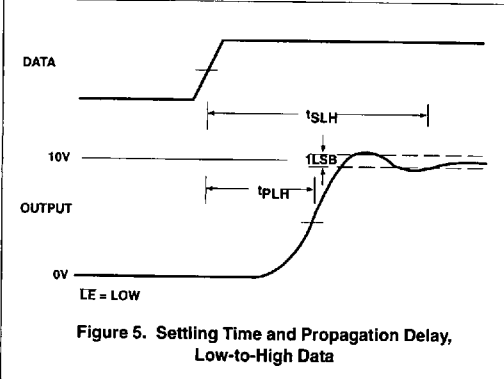

Figure 5. Settling Time and Propagation Delay, Low-to-High Data

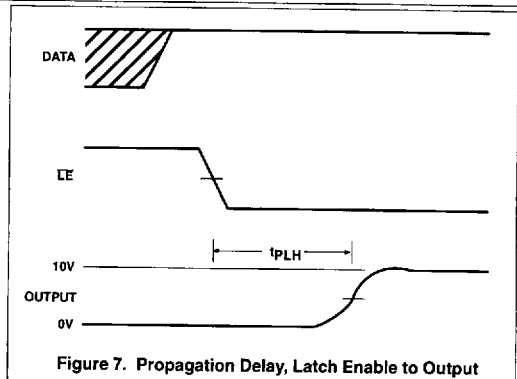

Figure 7. Propagation Delay, Latch Enable to Output

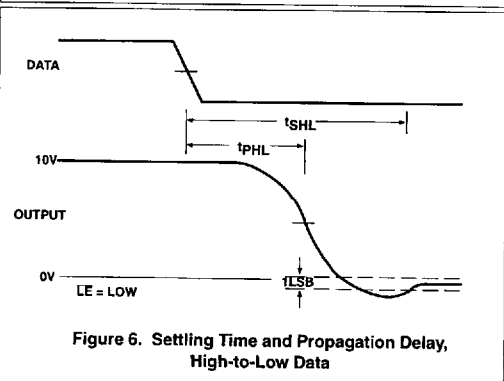

Figure 6. Settling Time and Propagation Delay, High-to-Low Data

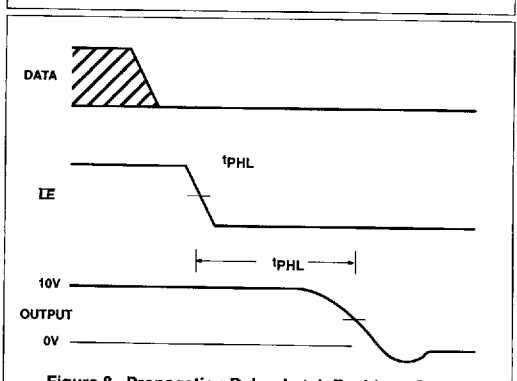

Figure 8. Propagation Delay, Latch Enable to Output

8-Bit μ p-compatible D/A converter

NE/SE5018/5019

