

Document No.	853–0683
ECN No.	99799
Date of Issue	June 14, 1990
Status	Product Specification
ECL Products	

# 10181

## Arithmetic Unit

### 4-Bit Arithmetic Logic Unit/Function Generator

#### FEATURES

- Typical propagation delay: 4.2ns
- Typical supply current ( $-I_{EE}$ ): 130mA

#### DESCRIPTION

The 10181 is a high-speed, Arithmetic Logic Unit. It performs 16 logic operations and 16 arithmetic operations on two 4-bit words. Arithmetic or logic mode of operation is selected by the mode control (M). Arithmetic logic operations are selected by a 4-bit select input ( $S_0 - S_3$ ) in accordance with the function table. The device provides a group Carry Propagate (PG) and a Carry Generate (GG) for high-speed operations on very long words, using a 10179 as a high order look-ahead carry block. The internal carry is enabled while the mode control input (M) is Low (arithmetic operation).

All unused inputs can be left open due to integrated pull-down resistors which avoid the need for a supply voltage.

#### ORDERING INFORMATION

DESCRIPTION	ORDER CODE
24-Pin Plastic DIP	10181N
24-Pin Ceramic DIP	10181F

#### PIN DESCRIPTION

PINS	DESCRIPTION
M	Mode Control Input
$A_0 - A_3, B_0 - B_3$	Operand Inputs
$S_0 - S_3$	Function Select Inputs
$C_n$	Carry Inputs
$F_0 - F_3$	Data Outputs
$C_{n+4}$	Carry Output
GG	Carry Generate Output
PG	Carry Propagate Output

#### PIN CONFIGURATION

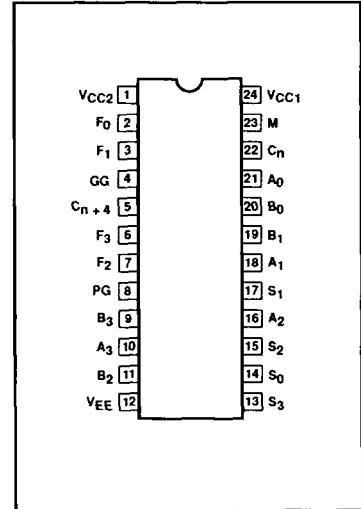

# Arithmetic Unit

10181

## LOGIC DIAGRAM

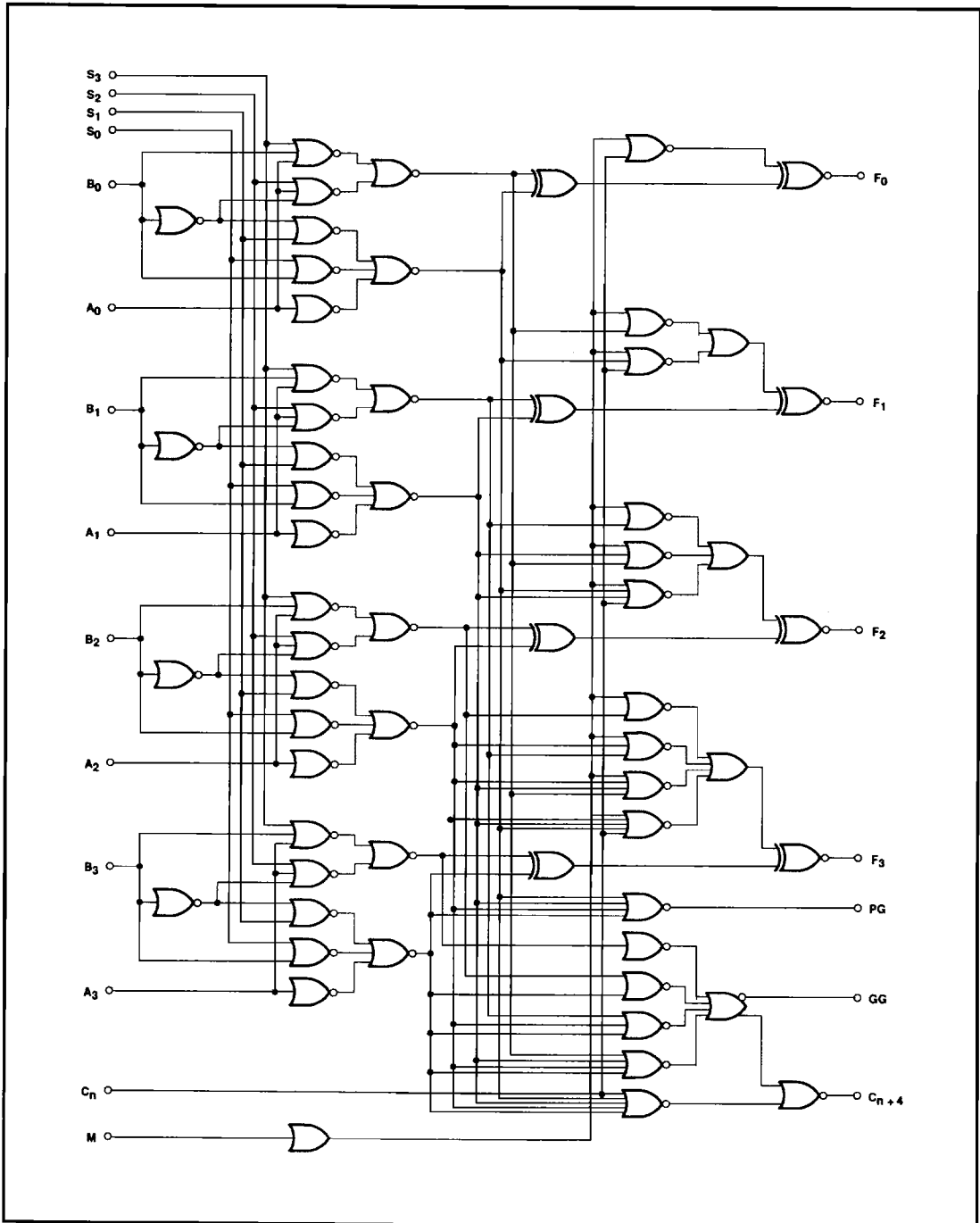

## Arithmetic Unit

10181

FUNCTION TABLE

FUNCTION SELECT INPUTS				OUTPUT FUNCTION F		
				M = HIGH (Logic Mode)	M = LOW (Arithmetic Mode)	
S <sub>3</sub>	S <sub>2</sub>	S <sub>1</sub>	S <sub>0</sub>	C <sub>n</sub> = H or L	C <sub>n</sub> = LOW	C <sub>n</sub> = HIGH
L	L	L	L	$\bar{A}$	A	A plus 1
L	L	L	H	$\bar{A} + \bar{B}$	A plus $A\bar{B}$	A plus $A\bar{B}$ plus 1
L	L	H	L	$\bar{A} + B$	A plus AB	A plus AB plus 1
L	L	H	H	HIGH	A plus A (2 times A)	A plus A plus 1
L	H	L	L	$\bar{A}\bar{B}$	A + B	(A + B) plus 1
L	H	L	H	$\bar{B}$	(A + B) plus $A\bar{B}$	(A + B) plus $A\bar{B}$ plus 1
L	H	H	L	$\bar{A}\oplus\bar{B}$	A plus B	A plus B plus 1
L	H	H	H	A + $\bar{B}$	(A + B) plus A	(A + B) plus A plus 1
H	L	L	L	$\bar{A}B$	A + $\bar{B}$	(A + $\bar{B}$ ) plus 1
H	L	L	H	$A\oplus\bar{B}$	A minus B minus 1	A minus B
H	L	H	L	B	(A + $\bar{B}$ ) plus AB	(A + $\bar{B}$ ) plus AB plus 1
H	L	H	H	A + B	(A + $\bar{B}$ ) plus A	(A + $\bar{B}$ ) plus A plus 1
H	H	L	L	LOW	- 1 (2's complement)	Zero
H	H	L	H	$A\bar{B}$	$A\bar{B}$ minus 1	$A\bar{B}$
H	H	H	L	AB	AB minus 1	AB
H	H	H	H	A	A minus 1	A

H = High Voltage Level

L = Low Voltage Level

## Arithmetic Unit

10181

## ABSOLUTE MAXIMUM RATINGS

SYMBOL	PARAMETER	LIMITS	UNIT	
$V_{EE}$	Supply voltage	-8.0	V	
$V_{IN}$	Input voltage ( $V_{IN}$ should never be more negative than $V_{EE}$ )	0 to $V_{EE}$	V	
$I_O$	Output source current (continuous)	-50	mA	
$T_S$	Storage temperature range	-55 to +150	°C	
$T_J$	Maximum junction temperature	Ceramic Package	+165	°C
		Plastic Package	+150	°C

## NOTE:

Operation beyond the limits set forth in this table may impair the useful life of the device. Unless otherwise noted, these limits are specified over the operating ambient temperature range.

## DC OPERATING CONDITIONS

SYMBOL	PARAMETER	TEST CONDITIONS	LIMITS			UNIT
			MIN.	NOM.	MAX.	
$V_{CC1}, V_{CC2}$	Circuit ground		0	0	0	V
$V_{EE}$	Supply voltage (negative)			-5.2		V
$V_{IH}$	High level input voltage	$T_A = -30^\circ\text{C}$			-890	mV
		$T_A = +25^\circ\text{C}$			-810	mV
		$T_A = +85^\circ\text{C}$			-700	mV
$V_{IHT}$	High level input threshold voltage	$T_A = -30^\circ\text{C}$	-1205			mV
		$T_A = +25^\circ\text{C}$	-1105			mV
		$T_A = +85^\circ\text{C}$	-1035			mV
$V_{ILT}$	Low level input threshold voltage	$T_A = -30^\circ\text{C}$			-1500	mV
		$T_A = +25^\circ\text{C}$			-1475	mV
		$T_A = +85^\circ\text{C}$			-1440	mV
$V_{IL}$	Low level input voltage	$T_A = -30^\circ\text{C}$	-1890			mV
		$T_A = +25^\circ\text{C}$	-1850			mV
		$T_A = +85^\circ\text{C}$	-1825			mV
$T_A$	Operating ambient temperature range		-30	+25	+85	°C

## NOTE:

When operating at other than the specified  $V_{EE}$  voltage (-5.2V), the DC and AC Electrical Characteristics will vary slightly from specified values.

# Arithmetic Unit

# 10181

## DC ELECTRICAL CHARACTERISTICS $V_{CC1} = V_{CC2} = \text{ground}, V_{EE} = -5.2V \pm 0.010V, T_A = -30^\circ\text{C to } +85^\circ\text{C}$ output loading $50\Omega$ to $-2.0V \pm 0.010V$ unless otherwise specified<sup>1,3</sup>

SYMBOL	PARAMETER		TEST CONDITIONS <sup>2</sup>	LIMITS			UNIT	
				MIN.	TYP.	MAX.		
$V_{OH}$	High level output voltage		$T_A = -30^\circ\text{C}$	-1060		-890	mV	
			$T_A = +25^\circ\text{C}$	-960		-810	mV	
			$T_A = +85^\circ\text{C}$	-890		-700	mV	
$V_{OHT}$	High level output threshold voltage		$T_A = -30^\circ\text{C}$	-1080			mV	
			$T_A = +25^\circ\text{C}$	-980			mV	
			$T_A = +85^\circ\text{C}$	-910			mV	
$V_{OLT}$	Low level output threshold voltage		$T_A = -30^\circ\text{C}$			-1655	mV	
			$T_A = +25^\circ\text{C}$			-1630	mV	
			$T_A = +85^\circ\text{C}$			-1595	mV	
$V_{OL}$	Low level output voltage		$T_A = -30^\circ\text{C}$	-1890		-1675	mV	
			$T_A = +25^\circ\text{C}$	-1850		-1650	mV	
			$T_A = +85^\circ\text{C}$	-1825		-1615	mV	
$I_{IH}$	High level input current	$A_n$ inputs	$T_A = -30^\circ\text{C}$			350	$\mu\text{A}$	
			$T_A = +25^\circ\text{C}$			220	$\mu\text{A}$	
			$T_A = +85^\circ\text{C}$			220	$\mu\text{A}$	
		$B_n$ inputs	$T_A = -30^\circ\text{C}$			390	$\mu\text{A}$	
			$T_A = +25^\circ\text{C}$			245	$\mu\text{A}$	
			$T_A = +85^\circ\text{C}$			245	$\mu\text{A}$	
		$S_n$ inputs	$T_A = -30^\circ\text{C}$	Apply $V_{IHMAX}$ to each input under test, one at a time, with $V_{ILMIN}$ applied to all other inputs.			425	$\mu\text{A}$
			$T_A = +25^\circ\text{C}$				265	$\mu\text{A}$
			$T_A = +85^\circ\text{C}$				265	$\mu\text{A}$
		$C_n$ input	$T_A = -30^\circ\text{C}$	Apply $V_{IHMAX}$ to $C_n$ input with $V_{ILMIN}$ applied to all other inputs.			460	$\mu\text{A}$
			$T_A = +25^\circ\text{C}$				290	$\mu\text{A}$
			$T_A = +85^\circ\text{C}$				290	$\mu\text{A}$
$M$ input	$T_A = -30^\circ\text{C}$	Apply $V_{IHMAX}$ to $M$ input with $V_{ILMIN}$ applied to all other inputs.			320	$\mu\text{A}$		
	$T_A = +25^\circ\text{C}$				200	$\mu\text{A}$		
	$T_A = +85^\circ\text{C}$				200	$\mu\text{A}$		
$I_{IL}$	Low level input current		$T_A = -30^\circ\text{C}$	0.5			$\mu\text{A}$	
			$T_A = +25^\circ\text{C}$	0.5			$\mu\text{A}$	
			$T_A = +85^\circ\text{C}$	0.3			$\mu\text{A}$	
$-I_{EE}$	$V_{EE}$ supply current		$T_A = -30^\circ\text{C}$			150	mA	
			$T_A = +25^\circ\text{C}$		130	145	mA	
			$T_A = +85^\circ\text{C}$			150	mA	

# Arithmetic Unit

10181

## DC ELECTRICAL CHARACTERISTICS (Continued)

SYMBOL	PARAMETER	TEST CONDITIONS <sup>2</sup>	LIMITS			UNIT
			MIN.	TYP.	MAX.	
$\frac{\Delta V_{OH}}{\Delta V_{EE}}$	High level output voltage compensation	$T_A = +25^\circ\text{C}$		0.016		V/V
$\frac{\Delta V_{OL}}{\Delta V_{EE}}$	Low level output voltage compensation			0.250		V/V
$\frac{\Delta V_{BB}}{\Delta V_{EE}}$	Reference bias voltage compensation			0.148		V/V

**NOTES:**

- The specified limits represent the worst case values for the parameter. Since these worst case values normally occur at the supply voltage and temperature extremes, additional noise immunity can be achieved by decreasing the allowable operating condition ranges.
- Conditions for testing shown in the tables are not necessarily worst case. For worst case testing guidelines, refer to DC Testing, Chapter 1, Section 3.
- The specified limits shown in the DC Electrical Characteristics table can be met only after thermal equilibrium has been established. Thermal equilibrium is established by applying power for at least 2 minutes, while maintaining transverse airflow of 2.5 meters/sec (500 linear feet/min) over the device, mounted either in a test socket or on a printed circuit board. Test voltage values are given in the DC Operating Conditions table.

## AC ELECTRICAL CHARACTERISTICS $V_{CC1} = V_{CC2} = \text{ground}, V_{EE} = -5.2\text{V} \pm 0.010\text{V}$

SYMBOL	PARAMETER	TEST CONDITIONS <sup>1</sup>	LIMITS						UNIT	
			$T_A = -30^\circ\text{C}$		$T_A = +25^\circ\text{C}$			$T_A = +85^\circ\text{C}$		
			MIN.	MAX.	MIN.	TYP.	MAX.	MIN.		MAX.
$t_{PLH}$ $t_{PHL}$	Propagation delay $C_n$ to $C_{n+4}$	Waveform 1 $A_0, A_1, A_2, A_3$	1.00 1.00	5.10 5.10	1.10 1.10	3.10 3.10	5.00 5.00	1.10 1.10	5.40 5.40	ns ns
$t_{TLH}$ $t_{THL}$	Transition time <sup>2</sup> $C_n$ to $C_{n+4}$	Waveform 1 $A_0, A_1, A_2, A_3$	1.00 1.00	3.20 3.20	1.00 1.00	2.00 2.00	3.00 3.00	1.00 1.00	3.20 3.20	ns ns
$t_{PLH}$ $t_{PHL}$	Propagation delay $C_n$ to $F_1$	Waveform 1 $A_0$	1.70 1.70	7.20 7.20	2.00 2.00	4.50 4.50	7.00 7.00	2.00 2.00	7.50 7.50	ns ns
$t_{TLH}$ $t_{THL}$	Transition time <sup>2</sup> $C_n$ to $F_1$	Waveform 1 $A_0$	1.30 1.30	5.30 5.30	1.50 1.50	3.00 3.00	5.00 5.00	1.50 1.50	5.30 5.30	ns ns
$t_{PLH}$ $t_{PHL}$	Propagation delay $A_1$ to $F_1$	Waveform 1	2.60 2.60	10.40 10.40	3.00 3.00	6.50 6.50	10.00 10.00	3.00 3.00	10.80 10.80	ns ns
$t_{TLH}$ $t_{THL}$	Transition time <sup>2</sup> $A_1$ to $F_1$	Waveform 1	1.30 1.30	5.40 5.40	1.50 1.50	3.00 3.00	5.00 5.00	1.50 1.50	5.30 5.30	ns ns
$t_{PLH}$ $t_{PHL}$	Propagation delay $A_1$ to PG	Waveform 1 $S_0, S_3$	1.60 1.60	7.00 7.00	2.00 2.00	5.00 5.00	6.50 6.50	2.00 2.00	7.00 7.00	ns ns
$t_{TLH}$ $t_{THL}$	Transition time <sup>2</sup> $A_1$ to PG	Waveform 1 $S_0, S_3$	0.80 0.80	3.70 3.70	1.10 1.10	2.00 2.00	3.50 3.50	1.10 1.10	3.80 3.80	ns ns
$t_{PLH}$ $t_{PHL}$	Propagation delay $A_1$ to GG	Waveform 1 $A_0, A_2, A_3, C_n$	1.10 1.10	7.40 7.40	2.00 2.00	4.50 4.50	7.00 7.00	1.30 1.30	7.70 7.70	ns ns
$t_{TLH}$ $t_{THL}$	Transition time <sup>2</sup> $A_1$ to GG	Waveform 1 $A_0, A_2, A_3, C_n$	1.20 1.20	5.10 5.10	1.50 1.50	4.00 4.00	5.00 5.00	1.20 1.20	5.30 5.30	ns ns
$t_{PLH}$ $t_{PHL}$	Propagation delay $A_1$ to $C_{n+4}$	Waveform 1 $A_0, A_2, A_3, C_n$	1.70 1.70	7.30 7.30	2.00 2.00	5.00 5.00	7.00 7.00	2.00 2.00	7.80 7.80	ns ns
$t_{TLH}$ $t_{THL}$	Transition time <sup>2</sup> $A_1$ to $C_{n+4}$	Waveform 1 $A_0, A_2, A_3, C_n$	1.00 1.00	3.10 3.10	1.00 1.00	2.00 2.00	3.00 3.00	1.00 1.00	3.20 3.20	ns ns
$t_{PLH}$ $t_{PHL}$	Propagation delay $B_1$ to $F_1$	Waveform 1 $S_3, C_n$	2.70 2.70	11.30 11.30	3.00 3.00	8.00 8.00	11.00 11.00	3.00 3.00	11.90 11.90	ns ns
$t_{TLH}$ $t_{THL}$	Transition time <sup>2</sup> $B_1$ to $F_1$	Waveform 1 $S_3, C_n$	1.20 1.20	5.30 5.30	1.50 1.50	3.50 3.50	5.00 5.00	1.50 1.50	5.30 5.30	ns ns
$t_{PLH}$ $t_{PHL}$	Propagation delay $B_1$ to PG	Waveform 1 $S_0, S_3$	1.60 1.60	7.70 7.70	2.00 2.00	6.00 6.00	7.50 7.50	2.00 2.00	8.00 8.00	ns ns
$t_{TLH}$ $t_{THL}$	Transition time <sup>2</sup> $B_1$ to PG	Waveform 1 $S_0, S_3$	1.00 1.00	3.60 3.60	1.00 1.00	2.00 2.00	3.50 3.50	1.10 1.10	3.90 3.90	ns ns

# Arithmetic Unit

10181

## AC ELECTRICAL CHARACTERISTICS (Continued)

SYMBOL	PARAMETER	TEST CONDITIONS <sup>1</sup>	LIMITS							UNIT
			T <sub>A</sub> = -30°C		T <sub>A</sub> = +25°C			T <sub>A</sub> = +85°C		
			MIN.	MAX.	MIN.	TYP.	MAX.	MIN.	MAX.	
t <sub>PLH</sub> t <sub>PHL</sub>	Propagation delay B <sub>1</sub> to GG	Waveform 1 S <sub>3</sub> , C <sub>n</sub>	1.70 1.70	8.20 8.20	2.00 2.00	6.00 6.00	8.00 8.00	2.00 2.00	8.60 8.60	ns ns
t <sub>TLH</sub> t <sub>THL</sub>	Transition time <sup>2</sup> B <sub>1</sub> to GG	Waveform 1 S <sub>3</sub> , C <sub>n</sub>	1.40 1.40	5.20 5.20	1.50 1.50	3.00 3.00	5.00 5.00	1.20 1.20	5.40 5.40	ns ns
t <sub>PLH</sub> t <sub>PHL</sub>	Propagation delay B <sub>1</sub> to C <sub>n+4</sub>	Waveform 1 S <sub>3</sub> , C <sub>n</sub>	1.80 1.80	8.20 8.20	2.00 2.00	6.00 6.00	8.00 8.00	2.00 2.00	8.70 8.70	ns ns
t <sub>TLH</sub> t <sub>THL</sub>	Transition time <sup>2</sup> B <sub>1</sub> to C <sub>n+4</sub>	Waveform 1 S <sub>3</sub> , C <sub>n</sub>	0.90 0.90	3.10 3.10	1.00 1.00	2.00 2.00	3.00 3.00	1.00 1.00	3.20 3.20	ns ns
t <sub>PLH</sub> t <sub>PHL</sub>	Propagation delay M to F <sub>1</sub>	Waveform 1	2.40 2.40	10.30 10.30	3.00 3.00	6.50 6.50	10.00 10.00	3.00 3.00	10.80 10.80	ns ns
t <sub>TLH</sub> t <sub>THL</sub>	Transition time <sup>2</sup> M to F <sub>1</sub>	Waveform 1	1.10 1.10	5.10 5.10	1.50 1.50	4.00 4.00	5.00 5.00	1.50 1.50	5.30 5.30	ns ns
t <sub>PLH</sub> t <sub>PHL</sub>	Propagation delay S <sub>1</sub> to F <sub>1</sub>	Waveform 1 A <sub>1</sub> , B <sub>1</sub>	2.50 2.50	10.70 10.70	3.00 3.00	6.50 6.50	10.00 10.00	3.00 3.00	10.80 10.80	ns ns
t <sub>TLH</sub> t <sub>THL</sub>	Transition time <sup>2</sup> S <sub>1</sub> to F <sub>1</sub>	Waveform 1 A <sub>3</sub> , B <sub>3</sub>	1.00 1.00	5.40 5.40	1.50 1.50	3.00 3.00	5.00 5.00	1.50 1.50	5.40 5.40	ns ns
t <sub>PLH</sub> t <sub>PHL</sub>	Propagation delay S <sub>1</sub> to PG	Waveform 1 A <sub>3</sub> , B <sub>3</sub>	1.70 1.70	8.30 8.30	2.00 2.00	6.00 6.00	8.00 8.00	2.00 2.00	8.40 8.40	ns ns
t <sub>TLH</sub> t <sub>THL</sub>	Transition time <sup>2</sup> S <sub>1</sub> to PG	Waveform 1 A <sub>3</sub> , B <sub>3</sub>	0.80 0.80	5.10 5.10	1.10 1.10	3.00 3.00	5.00 5.00	1.10 1.10	5.20 5.20	ns ns
t <sub>PLH</sub> t <sub>PHL</sub>	Propagation delay S <sub>1</sub> to C <sub>n+4</sub>	Waveform 1 A <sub>3</sub> , B <sub>3</sub>	1.60 1.60	9.30 9.30	2.00 2.00	6.00 6.00	9.00 9.00	2.00 2.00	9.90 9.90	ns ns
t <sub>TLH</sub> t <sub>THL</sub>	Transition time <sup>2</sup> S <sub>1</sub> to C <sub>n+4</sub>	Waveform 1 A <sub>3</sub> , B <sub>3</sub>	0.90 0.90	5.30 5.30	1.10 1.10	3.00 3.00	5.00 5.00	1.00 1.00	5.20 5.20	ns ns
t <sub>PLH</sub> t <sub>PHL</sub>	Propagation delay S <sub>1</sub> to GG	Waveform 1 A <sub>3</sub> , B <sub>3</sub>	1.50 1.50	9.60 9.60	2.00 2.00	6.00 6.00	9.00 9.00	1.90 1.90	9.70 9.70	ns ns
t <sub>TLH</sub> t <sub>THL</sub>	Transition time <sup>2</sup> S <sub>1</sub> to GG	Waveform 1 A <sub>3</sub> , B <sub>3</sub>	0.80 0.80	6.20 6.20	0.80 0.80	3.00 3.00	6.00 6.00	0.80 0.80	6.50 6.50	ns ns

**NOTES:**

1. Apply 1110mV to pins listed with 310mV applied to all other inputs.
2. All transition times are from 20% to 80% and 80% to 20% (refer to Waveform 1).
3. For AC test setup information, see AC Testing, Chapter 2, Section 3.

## AC WAVEFORMS

