

**SLA7027MU/SLA7024M/SLA7026M**

**2-Phase/1-2 Phase Excitation**

**Absolute Maximum Ratings**

(T<sub>a</sub>=25°C)

Parameter	Symbol	Ratings			Unit
		SLA7027MU	SLA7024M	SLA7026M	
Motor Supply Voltage	V <sub>CC</sub>	46			V
FET Drain-Source Voltage	V <sub>DSS</sub>	100			V
Control Supply Voltage	V <sub>S</sub>	46			V
Input Voltage	V <sub>IN</sub>	7			V
Reference Voltage	V <sub>REF</sub>	2			V
Output Current	I <sub>O</sub>	1	1.5	3	A
Power Dissipation	P <sub>D1</sub>	4.5 (Without Heatsink)			W
	P <sub>D2</sub>	35 (T <sub>C</sub> =25°C)			W
Channel Temperature	T <sub>ch</sub>	+150			°C
Storage Temperature	T <sub>stg</sub>	-40 to +150			°C

**Electrical Characteristics**

Parameter	Symbol	Ratings									Unit
		SLA7027MU			SLA7024M			SLA7026M			
		min.	typ.	max.	min.	typ.	max.	min.	typ.	max.	
Control Supply Current	I <sub>S</sub>		10	15		10	15		10	15	mA
	Condition	V <sub>S</sub> =44V			V <sub>S</sub> =44V			V <sub>S</sub> =44V			
Control Supply Voltage	V <sub>S</sub>	10	24	44	10	24	44	10	24	44	V
FET Drain-Source Voltage	V <sub>DSS</sub>	100			100			100			V
	Condition	V <sub>S</sub> =44V, I <sub>DSS</sub> =250μA			V <sub>S</sub> =44V, I <sub>DSS</sub> =250μA			V <sub>S</sub> =44V, I <sub>DSS</sub> =250μA			
FET ON Voltage	V <sub>DS</sub>			0.85			0.6			0.85	V
	Condition	I <sub>D</sub> =1A, V <sub>S</sub> =14V			I <sub>D</sub> =1A, V <sub>S</sub> =14V			I <sub>D</sub> =3A, V <sub>S</sub> =14V			
FET Drain Leakage Current	I <sub>DSS</sub>			4			4			4	mA
	Condition	V <sub>DSS</sub> =100V, V <sub>S</sub> =44V			V <sub>DSS</sub> =100V, V <sub>S</sub> =44V			V <sub>DSS</sub> =100V, V <sub>S</sub> =44V			
FET Diode Forward Voltage	V <sub>SD</sub>			1.2			1.1			2.3	V
	Condition	I <sub>D</sub> =1A			I <sub>D</sub> =1A			I <sub>D</sub> =3A			
TTL Input Current	I <sub>IH</sub>			40			40			40	μA
	Condition	V <sub>IH</sub> =2.4V, V <sub>S</sub> =44V			V <sub>IH</sub> =2.4V, V <sub>S</sub> =44V			V <sub>IH</sub> =2.4V, V <sub>S</sub> =44V			
	I <sub>IL</sub>			-0.8			-0.8			-0.8	
TTL Input Voltage (Active High)	V <sub>IH</sub>	2			2			2			V
	Condition	I <sub>D</sub> =1A			I <sub>D</sub> =1A			I <sub>D</sub> =3A			
	V <sub>IL</sub>			0.8			0.8			0.8	
TTL Input Voltage (Active Low)	V <sub>IH</sub>	2			2			2			V
	Condition	V <sub>DSS</sub> =100V			V <sub>DSS</sub> =100V			V <sub>DSS</sub> =100V			
	V <sub>IL</sub>			0.8			0.8			0.8	
Switching Time	T <sub>r</sub>		0.5			0.5			0.5		μs
	Condition	V <sub>S</sub> =24V, I <sub>D</sub> =0.8A			V <sub>S</sub> =24V, I <sub>D</sub> =1A			V <sub>S</sub> =24V, I <sub>D</sub> =1A			
	T <sub>sig</sub>		0.7			0.7			0.7		
	Condition	V <sub>S</sub> =24V, I <sub>D</sub> =0.8A			V <sub>S</sub> =24V, I <sub>D</sub> =1A			V <sub>S</sub> =24V, I <sub>D</sub> =1A			
	T <sub>f</sub>		0.1			0.1			0.1		
Condition	V <sub>S</sub> =24V, I <sub>D</sub> =0.8A			V <sub>S</sub> =24V, I <sub>D</sub> =1A			V <sub>S</sub> =24V, I <sub>D</sub> =1A				

Internal Block Diagram

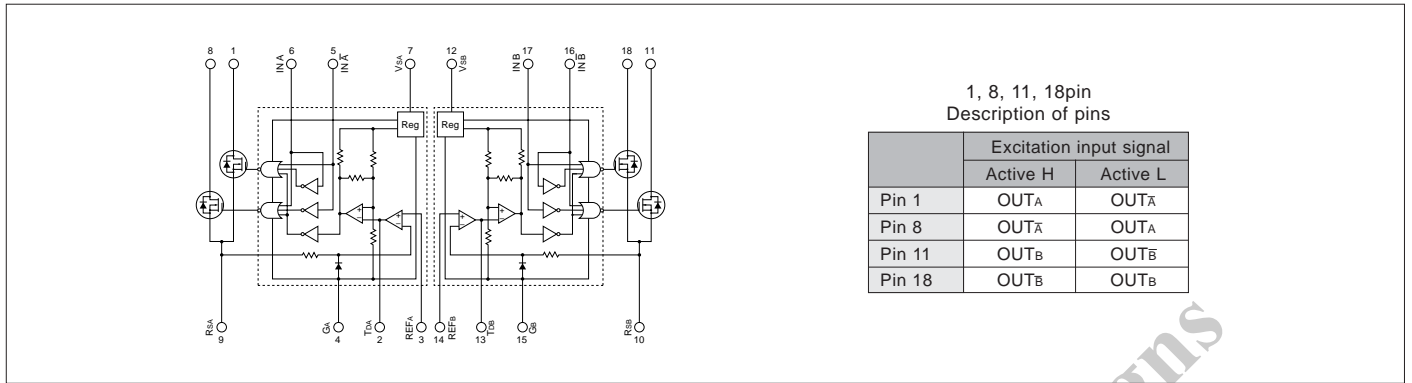

Typical Connection Diagram (Recommended component values)

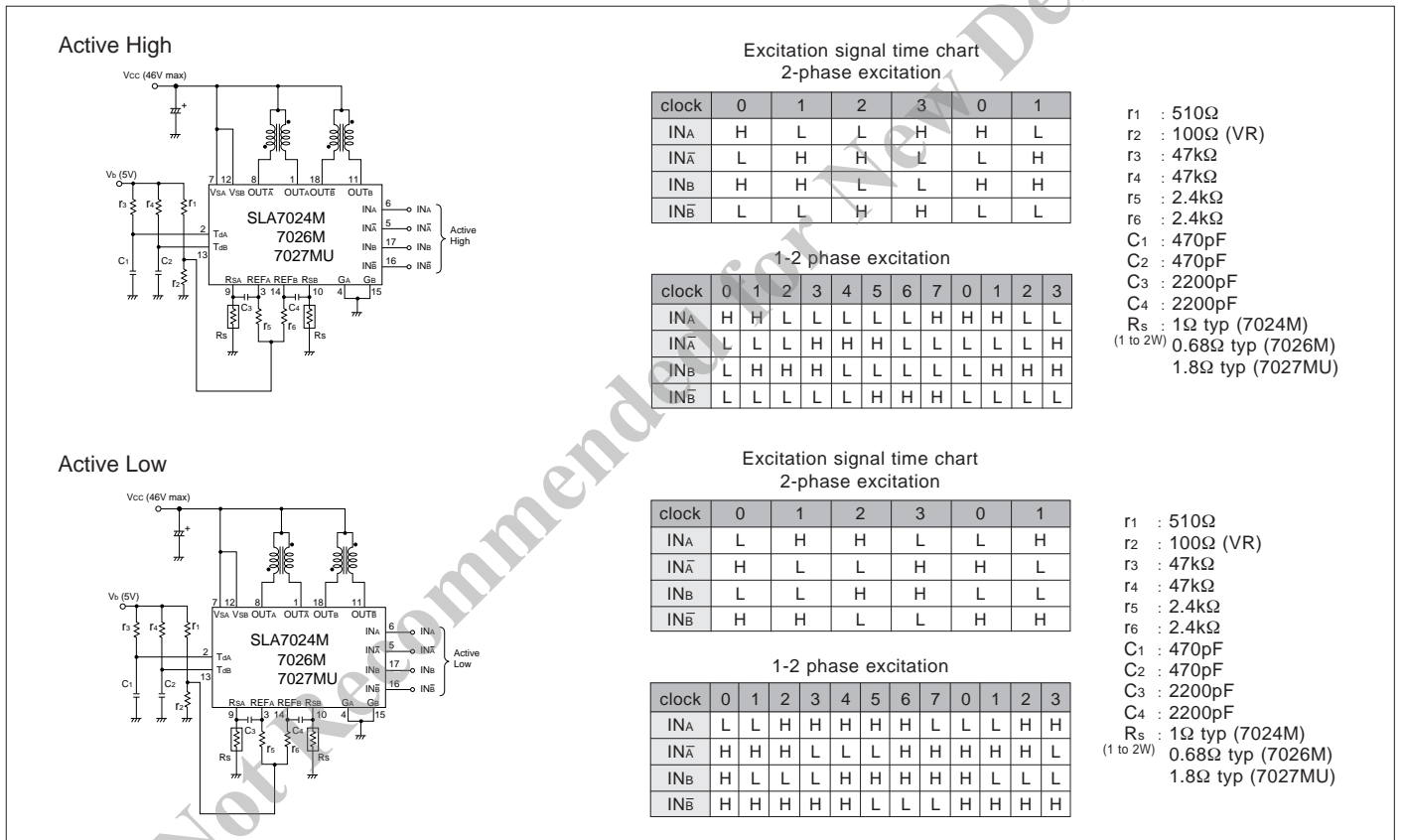

External Dimensions (ZIP18 with Fin [SLA18Pin])

(Unit : mm)

