

# 74279 Latch

## Quad Set-Reset Latch Product Specification

Logic Products

TYPE	TYPICAL PROPAGATION DELAY	TYPICAL SUPPLY CURRENT (TOTAL)
74279	13ns	18mA

### FUNCTION TABLE

INPUTS			OUTPUT
$\bar{S}_1$	$\bar{S}_2$	$\bar{R}$	Q
L	L	L	h
L	X	H	H
X	L	H	H
H	H	L	L
H	H	H	No change

L = LOW voltage level.

H = HIGH voltage level.

X = Don't care.

h = The output is HIGH as long as  $\bar{S}_1$  or  $\bar{S}_2$  is LOW.

If all inputs go HIGH simultaneously, the output state is indeterminate; otherwise, it follows the truth table.

### ORDERING CODE

PACKAGES	COMMERCIAL RANGE $V_{CC} = 5V \pm 5\%$ ; $T_A = 0^\circ C$ to $+70^\circ C$
Plastic DIP	N74279N
Plastic SO-16	N74279D

#### NOTE:

For information regarding devices processed to Military Specifications, see the Signetics Military Products Data Manual.

### INPUT AND OUTPUT LOADING AND FAN-OUT TABLE

PINS	DESCRIPTION	74
All	Inputs	1ul
Q	Output	10ul

#### NOTE:

A 74 unit load (ul) is  $40\mu A$   $I_{IH}$  and  $-1.6mA$   $I_{IL}$ .

### PIN CONFIGURATION

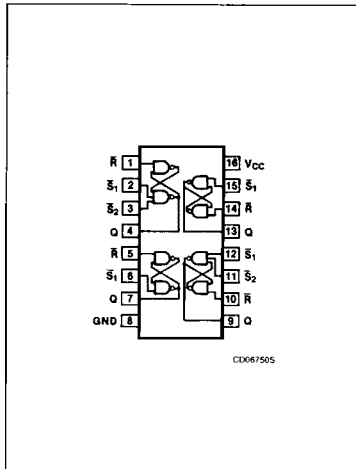

### LOGIC SYMBOL

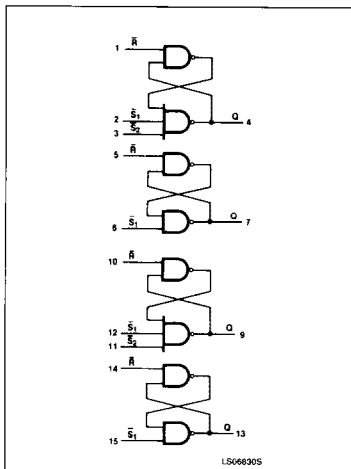

### LOGIC SYMBOL (IEEE/IEC)

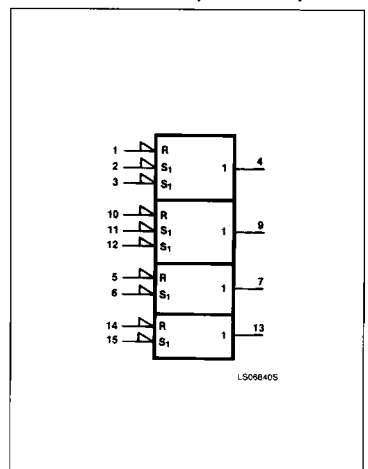

## Latch

74279

**ABSOLUTE MAXIMUM RATINGS** (Over operating free-air temperature range unless otherwise noted.)

PARAMETER		74	UNIT
$V_{CC}$	Supply voltage	7.0	V
$V_{IN}$	Input voltage	-0.5 to +5.5	V
$I_{IN}$	Input current	-30 to +5	mA
$V_{OUT}$	Voltage applied to output in HIGH output state	-0.5 to + $V_{CC}$	V
$T_A$	Operating free-air temperature range	0 to 70	°C

**RECOMMENDED OPERATING CONDITIONS**

PARAMETER		74			UNIT
		Min	Nom	Max	
$V_{CC}$	Supply voltage	4.75	5.0	5.25	V
$V_{IH}$	HIGH-level input voltage	2.0			V
$V_{IL}$	LOW-level input voltage			+0.8	V
$I_{IK}$	Input clamp current			-12	mA
$I_{OH}$	HIGH-level output current			-800	$\mu$ A
$I_{OL}$	LOW-level output current			16	mA
$T_A$	Operating free-air temperature	0		70	°C

**DC ELECTRICAL CHARACTERISTICS** (Over recommended operating free-air temperature range unless otherwise noted.)

PARAMETER		TEST CONDITIONS <sup>1</sup>	74279			UNIT
			Min	Typ <sup>2</sup>	Max	
$V_{OH}$	HIGH-level output voltage	$V_{CC} = \text{MIN}, V_{IH} = \text{MIN}, V_{IL} = \text{MAX}, I_{OH} = \text{MAX}$	2.4	3.4		V
$V_{OL}$	LOW-level output voltage	$V_{CC} = \text{MIN}, V_{IH} = \text{MIN}, V_{IL} = \text{MAX}, I_{OL} = \text{MAX}$		0.2	0.4	V
$V_{IK}$	Input clamp voltage	$V_{CC} = \text{MIN}, I_I = I_{IK}$			-1.5	V
$I_I$	Input current at maximum input voltage	$V_{CC} = \text{MAX}, V_I = 5.5\text{V}$			1.0	mA
$I_{IH}$	HIGH-level input current	$V_{CC} = \text{MAX}, V_I = 2.4\text{V}$			40	$\mu$ A
$I_{IL}$	LOW-level input current	$V_{CC} = \text{MAX}, V_I = 0.4\text{V}$			-1.6	mA
$I_{OS}$	Short-circuit output current <sup>3</sup>	$V_{CC} = \text{MAX}$	-18		-57	mA
$I_{CC}$	Supply current <sup>4</sup> (total)	$V_{CC} = \text{MAX}$		18	30	mA

**NOTES:**

- For conditions shown as MIN or MAX, use the appropriate value specified under recommended operating conditions for the applicable type.
- All typical values are at  $V_{CC} = 5\text{V}$ ,  $T_A = 25^\circ\text{C}$ .
- $I_{OS}$  is tested with  $V_{OUT} = +0.5\text{V}$  and  $V_{CC} = V_{CC} \text{ MAX} + 0.5\text{V}$ . Not more than one output should be shorted at a time and duration of the short circuit should not exceed one second.
- Measure  $I_{CC}$  with all  $\bar{R}$  inputs grounded, all  $\bar{S}$  inputs at 4.5V, and all outputs open.

# Latch

74279

## AC ELECTRICAL CHARACTERISTICS $T_A = 25^\circ\text{C}$ , $V_{CC} = 5.0\text{V}$

PARAMETER	TEST CONDITIONS	74		UNIT
		$C_L = 15\text{pF}$ , $R_L = 400\Omega$		
		Min	Max	
$t_{PLH}$ $t_{PHL}$	Propagation delay Set to output	Waveform 1	22 15	ns
$t_{PHL}$	Propagation delay Reset to output	Waveform 2	27	ns

## AC WAVEFORMS

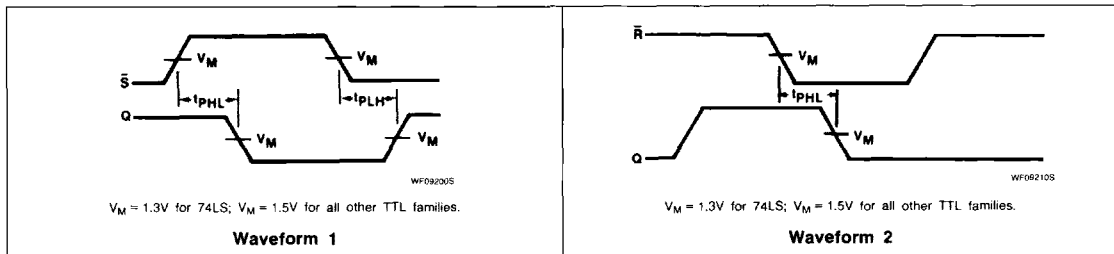

## TEST CIRCUITS AND WAVEFORMS

