

**SN54LVT18640, SN54LVT182640, SN74LVT18640, SN74LVT182640**  
**3.3-V ABT SCAN TEST DEVICES**  
**WITH 18-BIT INVERTING BUS TRANSCEIVERS**

SCBS310A - MARCH 1994 - REVISED AUGUST 1994

- Members of the Texas Instruments **SCOPE™** Family of Testability Products
- Members of the Texas Instruments **Widebus™** Family
- State-of-the-Art 3.3-V ABT Design Supports Mixed-Mode Signal Operation (5-V Input and Output Voltages With 3.3-V  $V_{CC}$ )
- Support Unregulated Battery Operation Down to 2.7 V
- Bus-Hold Data Inputs Eliminate the Need for External Pullup Resistors
- B-Port Outputs of LVT182640 Devices Have Equivalent 25- $\Omega$  Series Resistors, So No External Resistors Are Required
- Compatible With the IEEE Standard 1149.1-1990 (JTAG) Test Access Port and Boundary-Scan Architecture
- **SCOPE™** Instruction Set
  - IEEE Standard 1149.1-1990 Required Instructions and Optional CLAMP and HIGHZ
  - Parallel-Signature Analysis at Inputs
  - Pseudo-Random Pattern Generation From Outputs
  - Sample Inputs/Toggle Outputs
  - Binary Count From Outputs
  - Device Identification
  - Even-Parity Opcodes
- Packaged in Thin Shrink Small-Outline (DGG) and Plastic 300-mil Shrink Small-Outline (DL) Packages and 380-mil Fine-Pitch Ceramic Flat (WD) Packages Using 25-mil Center-to-Center Spacings

SN54LVT18640 . . . WD PACKAGE  
 SN74LVT18640 . . . DGG OR DL PACKAGE  
 (TOP VIEW)

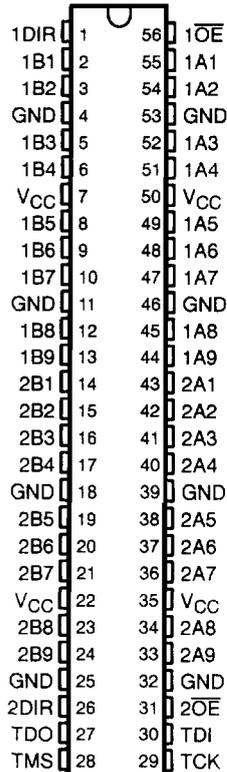

**PRODUCT PREVIEW**

**description**

The LVT18640 and LVT182640 scan test devices with 18-bit inverting bus transceivers are members of the Texas Instruments SCOPE™ testability integrated circuit family. This family of devices supports IEEE Standard 1149.1-1990 boundary scan to facilitate testing of complex circuit-board assemblies. Scan access to the test circuitry is accomplished via the 4-wire test access port (TAP) interface.

Additionally, these devices are designed specifically for low-voltage (3.3-V)  $V_{CC}$  operation, but with the capability to provide a TTL interface to a 5-V system environment.

In the normal mode, these devices are 18-bit inverting bus transceivers. They can be used either as two 9-bit transceivers or one 18-bit transceiver. The test circuitry can be activated by the TAP to take snapshot samples of the data appearing at the device pins or to perform a self test on the boundary-test cells. Activating the TAP in the normal mode does not affect the functional operation of the SCOPE™ bus transceivers.

Data flow is controlled by the direction-control (DIR) and output-enable ( $\overline{OE}$ ) inputs. Data transmission is allowed from the A bus to the B bus or from the B bus to the A bus depending upon the logic level at DIR. The output-enable ( $\overline{OE}$ ) can be used to disable the device so that the buses are effectively isolated.

SCOPE and Widebus are trademarks of Texas Instruments Incorporated.

PRODUCT PREVIEW information concerns products in the formative or design phase of development. Characteristic data and other specifications are design goals. Texas Instruments reserves the right to change or discontinue these products without notice.



Copyright © 1994, Texas Instruments Incorporated

**SN54LVT18640, SN54LVT182640, SN74LVT18640, SN74LVT182640**  
**3.3-V ABT SCAN TEST DEVICES**  
**WITH 18-BIT INVERTING BUS TRANSCEIVERS**

SCBS310A - MARCH 1994 - REVISED AUGUST 1994

**description (continued)**

In the test mode, the normal operation of the SCOPE™ bus transceivers is inhibited and the test circuitry is enabled to observe and control the I/O boundary of the device. When enabled, the test circuitry performs boundary-scan test operations according to the protocol described in IEEE Standard 1149.1-1990.

Four dedicated test pins observe and control the operation of the test circuitry: test data input (TDI), test data output (TDO), test mode select (TMS), and test clock (TCK). Additionally, the test circuitry performs other testing functions such as parallel-signature analysis (PSA) on data inputs and pseudo-random pattern generation (PRPG) from data outputs. All testing and scan operations are synchronized to the TAP interface.

Active bus-hold circuitry is provided to hold unused or floating data inputs at a valid logic level.

The B-port outputs of LVT182640, which are designed to source or sink up to 12 mA, include 25-Ω series resistors to reduce overshoot and undershoot.

The SN74LVT18640 and SN74LVT182640 are available in TI's shrink small-outline (DL) and thin shrink small-outline (DGG) packages, which provide twice the I/O pin count and functionality of standard small-outline packages in the same printed-circuit-board area.

The SN54LVT18640 and SN74LVT182640 are characterized for operation over the full military temperature range of -55°C to 125°C. The SN74LVT18640 and SN74LVT182640 are characterized for operation from -40°C to 85°C.

**FUNCTION TABLE**  
(normal mode, each 9-bit section)

INPUTS		OPERATION
OE	DIR	
L	L	$\bar{B}$ data to A bus
L	H	$\bar{A}$ data to B bus
H	X	Isolation

PRODUCT PREVIEW



**SN54LVT18640, SN54LVT182640, SN74LVT18640, SN74LVT182640**  
**3.3-V ABT SCAN TEST DEVICES**  
**WITH 18-BIT INVERTING BUS TRANSCEIVERS**  
SCBS310A - MARCH 1994 - REVISED AUGUST 1994

**functional block diagram**

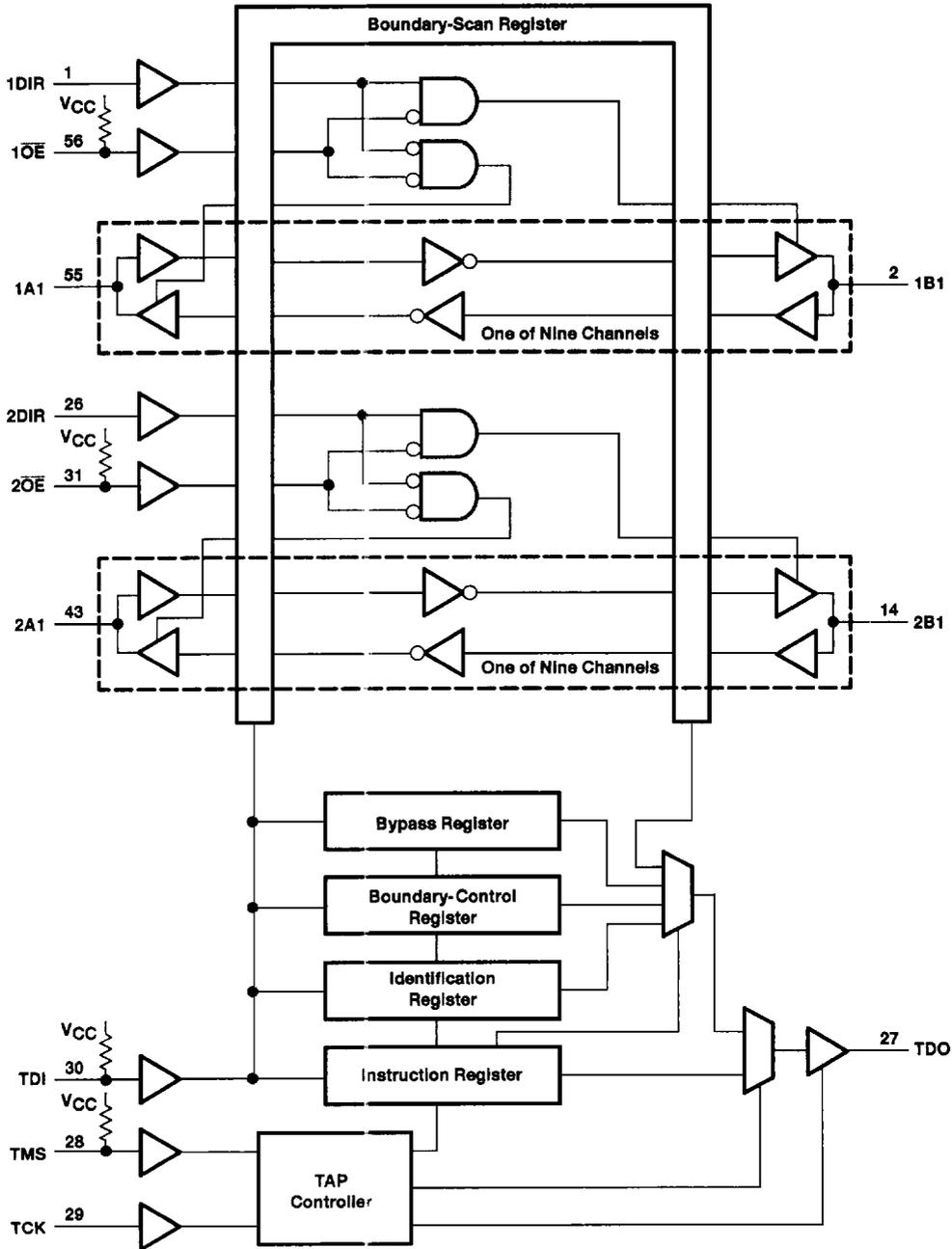

**PRODUCT PREVIEW**



**SN54LVT18640, SN54LVT182640, SN74LVT18640, SN74LVT182640**  
**3.3-V ABT SCAN TEST DEVICES**  
**WITH 18-BIT INVERTING BUS TRANSCEIVERS**

SCBS310A – MARCH 1994 – REVISED AUGUST 1994

**Terminal Functions**

TERMINAL NAME	DESCRIPTION
1A1–1A9, 2A1–2A9	Normal-function A-bus I/O ports. See function table for normal-mode logic.
1B1–1B9, 2B1–2B9	Normal-function B-bus I/O ports. See function table for normal-mode logic.
1DIR, 2DIR	Normal-function direction controls. See function table for normal-mode logic.
GND	Ground
$1\overline{OE}$ , $2\overline{OE}$	Normal-function output enables. See function table for normal-mode logic. An internal pullup at each terminal forces the terminal to a high level if left unconnected.
TCK	Test clock. One of four terminals required by IEEE Standard 1149.1-1990. Test operations of the device are synchronous to TCK. Data is captured on the rising edge of TCK and outputs change on the falling edge of TCK.
TDI	Test data input. One of four terminals required by IEEE Standard 1149.1-1990. TDI is the serial input for shifting data through the instruction register or selected data register. An internal pullup forces TDI to a high level if left unconnected.
TDO	Test data output. One of four terminals required by IEEE Standard 1149.1-1990. TDO is the serial output for shifting data through the instruction register or selected data register.
TMS	Test mode select. One of four terminals required by IEEE Standard 1149.1-1990. TMS directs the device through its TAP controller states. An internal pullup forces TMS to a high level if left unconnected.
V <sub>CC</sub>	Supply voltage

PRODUCT PREVIEW



POST OFFICE BOX 655303 • DALLAS, TEXAS 75266

**SN54LVT18640, SN54LVT182640, SN74LVT18640, SN74LVT182640**  
**3.3-V ABT SCAN TEST DEVICES**  
**WITH 18-BIT INVERTING BUS TRANSCEIVERS**

SCBS310A - MARCH 1994 - REVISED AUGUST 1994

**test architecture**

Serial-test information is conveyed by means of a 4-wire test bus or TAP, that conforms to IEEE Standard 1149.1-1990. Test instructions, test data, and test control signals all are passed along this serial-test bus. The TAP controller monitors two signals from the test bus, namely TCK and TMS. The TAP controller extracts the synchronization (TCK) and state control (TMS) signals from the test bus and generates the appropriate on-chip control signals for the test structures in the device. Figure 1 shows the TAP-controller state diagram.

The TAP controller is fully synchronous to the TCK signal. Input data is captured on the rising edge of TCK and output data changes on the falling edge of TCK. This scheme ensures data to be captured is valid for fully one-half of the TCK cycle.

The functional block diagram illustrates the IEEE Standard 1149.1-1990 4-wire test bus and boundary-scan architecture and the relationship among the test bus, the TAP controller, and the test registers. As illustrated, the device contains an 8-bit instruction register and four test-data registers: a 44-bit boundary-scan register, a 3-bit boundary-control register, a 1-bit bypass register, and a 32-bit device-identification register.

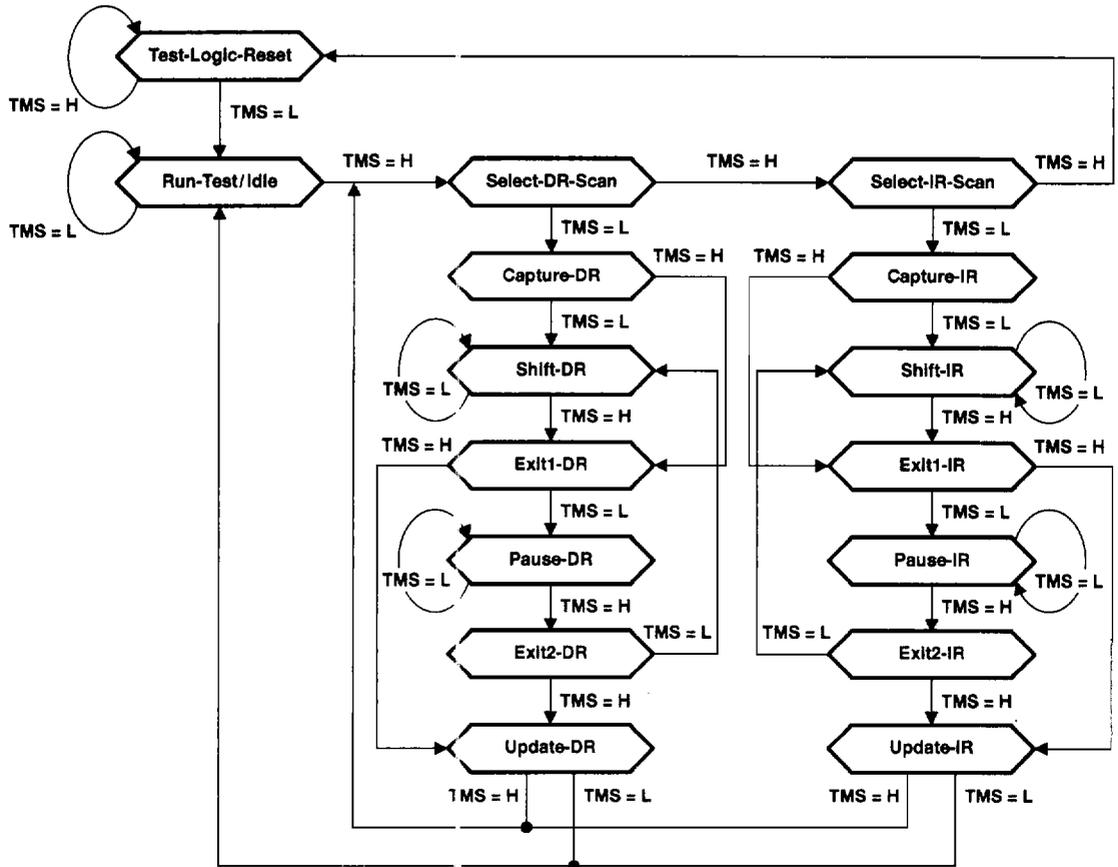

Figure 1. TAP-Controller State Diagram

**PRODUCT PREVIEW**



# SN54LVT18640, SN54LVT182640, SN74LVT18640, SN74LVT182640 3.3-V ABT SCAN TEST DEVICES WITH 18-BIT INVERTING BUS TRANSCEIVERS

SCBS310A – MARCH 1994 – REVISED AUGUST 1994

---

## state diagram description

The TAP controller is a synchronous finite state machine that provides test control signals throughout the device. The state diagram is illustrated in Figure 1 and is in accordance with IEEE Standard 1149.1-1990. The TAP controller proceeds through its states based on the level of TMS at the rising edge of TCK.

As illustrated, the TAP controller consists of 16 states. There are six stable states (indicated by a looping arrow in the state diagram) and ten unstable states. A stable state is a state the TAP controller can retain for consecutive TCK cycles. Any state that does not meet this criterion is an unstable state.

There are two main paths through the state diagram: one to access and control the selected data register and one to access and control the instruction register. Only one register can be accessed at a time.

## Test-Logic-Reset

The device powers up in the Test-Logic-Reset state. In the stable Test-Logic-Reset state, the test logic is reset and is disabled so that the normal logic function of the device is performed. The instruction register is reset to an opcode that selects the optional IDCODE instruction, if supported, or the BYPASS instruction. Certain data registers also can be reset to their power-up values.

The state machine is constructed such that the TAP controller returns to the Test-Logic-Reset state in no more than five TCK cycles if TMS is left high. The TMS pin has an internal pullup resistor that forces it high if left unconnected or if a board defect causes it to be open circuited.

For the LVT18640 and LVT182640, the instruction register is reset to the binary value 10000001, which selects the IDCODE instruction. Bits 43–40 in the boundary-scan register are reset to logic 0, ensuring that these cells, which control A-port and B-port outputs, are set to benign values (i.e., if test mode were invoked, the outputs would be at high-impedance state). Reset values of other bits in the boundary-scan register should be considered indeterminate. The boundary-control register is reset to the binary value 010, which selects the PSA test operation.

## Run-Test/Idle

The TAP controller must pass through the Run-Test/Idle state (from Test-Logic-Reset) before executing any test operations. The Run-Test/Idle state also can be entered following data-register or instruction-register scans. Run-Test/Idle is a stable state in which the test logic can be actively running a test or can be idle. The test operations selected by the boundary-control register are performed while the TAP controller is in the Run-Test/Idle state.

## Select-DR-Scan, Select-IR-Scan

No specific function is performed in the Select-DR-Scan and Select-IR-Scan states, and the TAP controller exits either of these states on the next TCK cycle. These states allow the selection of either data-register scan or instruction-register scan.

## Capture-DR

When a data-register scan is selected, the TAP controller must pass through the Capture-DR state. In the Capture-DR state, the selected data register can capture a data value as specified by the current instruction. Such capture operations occur on the rising edge of TCK upon which the TAP controller exits the Capture-DR state.

## Shift-DR

Upon entry to the Shift-DR state, the data register is placed in the scan path between TDI and TDO, and on the first falling edge of TCK, TDO goes from the high-impedance state to an active state. TDO enables to the logic level present in the least significant bit of the selected data register.

**SN54LVT18640, SN54LVT182640, SN74LVT18640, SN74LVT182640**  
**3.3-V ABT SCAN TEST DEVICES**  
**WITH 18-BIT INVERTING BUS TRANSCEIVERS**

SCBS310A – MARCH 1994 – REVISED AUGUST 1994

**Shift-DR (continued)**

While in the stable Shift-DR state, data is serially shifted through the selected data register on each TCK cycle. The first shift occurs on the first rising edge of TCK after entry to the Shift-DR state (i.e., no shifting occurs during the TCK cycle in which the TAP controller changes from Capture-DR to Shift-DR or from Exit2-DR to Shift-DR). The last shift occurs on the rising edge of TCK upon which the TAP controller exits the Shift-DR state.

**Exit1-DR, Exit2-DR**

The Exit1-DR and Exit2-DR states are temporary states that end a data-register scan. It is possible to return to the Shift-DR state from either Exit1-DR or Exit2-DR without recapturing the data register. On the first falling edge of TCK after entry to Exit1-DR, TDO goes from the active state to the high-impedance state.

**Pause-DR**

No specific function is performed in the stable Pause-DR state, in which the TAP controller can remain indefinitely. The Pause-DR state suspends and resumes data-register scan operations without loss of data.

**Update-DR**

If the current instruction calls for the selected data register to be updated with current data, such update occurs on the falling edge of TCK following entry to the Update-DR state.

**Capture-IR**

When an instruction-register scan is selected, the TAP controller must pass through the Capture-IR state. In the Capture-IR state, the instruction register captures its current status value. This capture operation occurs on the rising edge of TCK upon which the TAP controller exits the Capture-IR state. For the 'LVT18640 and 'LVT182640, the status value loaded in the Capture-IR state is the fixed binary value 10000001.

**Shift-IR**

Upon entry to the Shift-IR state, the instruction register is placed in the scan path between TDI and TDO, and on the first falling edge of TCK, TDO goes from the high-impedance state to an active state. TDO enables to the logic level present in the least significant bit of the instruction register.

While in the stable Shift-IR state, instruction data is serially shifted through the instruction register on each TCK cycle. The first shift occurs on the first rising edge of TCK after entry to the Shift-IR state (i.e., no shifting occurs during the TCK cycle in which the TAP controller changes from Capture-IR to Shift-IR or from Exit2-IR to Shift-IR). The last shift occurs on the rising edge of TCK upon which the TAP controller exits the Shift-IR state.

**Exit1-IR, Exit2-IR**

The Exit1-IR and Exit2-IR states are temporary states that end an instruction-register scan. It is possible to return to the Shift-IR state from either Exit1-IR or Exit2-IR without recapturing the instruction register. On the first falling edge of TCK after entry to Exit1-IR, TDO goes from the active state to the high-impedance state.

**Pause-IR**

No specific function is performed in the stable Pause-IR state, in which the TAP controller can remain indefinitely. The Pause-IR state suspends and resumes instruction-register scan operations without loss of data.

**Update-IR**

The current instruction is updated and takes effect on the falling edge of TCK following entry to the Update-IR state.

**PRODUCT PREVIEW**



# SN54LVT18640, SN54LVT182640, SN74LVT18640, SN74LVT182640 3.3-V ABT SCAN TEST DEVICES WITH 18-BIT INVERTING BUS TRANSCEIVERS

SCBS310A – MARCH 1994 – REVISED AUGUST 1994

## register overview

With the exception of the bypass and device-identification registers, any test register can be thought of as a serial-shift register with a shadow latch on each bit. The bypass and device-identification registers differ in that they contain only a shift register. During the appropriate capture state (Capture-IR for instruction register, Capture-DR for data registers), the shift register can be parallel loaded from a source specified by the current instruction. During the appropriate shift state (Shift-IR or Shift-DR), the contents of the shift register are shifted out from TDO while new contents are shifted in at TDI. During the appropriate update state (Update-IR or Update-DR), the shadow latches are updated from the shift register.

## instruction register description

The instruction register (IR) is eight bits long and tells the device what instruction is to be executed. Information contained in the instruction includes the mode of operation (either normal mode, in which the device performs its normal logic function, or test mode, in which the normal logic function is inhibited or altered), the test operation to be performed, which of the four data registers is to be selected for inclusion in the scan path during data-register scans, and the source of data to be captured into the selected data register during Capture-DR.

Table 3 lists the instructions supported by the 'LVT18640 and 'LVT182640. The even-parity feature specified for SCOPE™ devices is supported in this device. Bit 7 of the instruction opcode is the parity bit. Any instructions that are defined for SCOPE™ devices but are not supported by this device default to BYPASS.

During Capture-IR, the IR captures the binary value 10000001. As an instruction is shifted in, this value is shifted out via TDO and can be inspected as verification that the IR is in the scan path. During Update-IR, the value that has been shifted into the IR is loaded into shadow latches. At this time, the current instruction is updated and any specified mode change takes effect. At power up or in the Test-Logic-Reset state, the IR is reset to the binary value 10000001, which selects the IDCODIE instruction. The IR order of scan is illustrated in Figure 2.

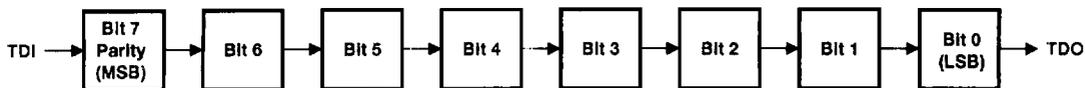

Figure 2. Instruction Register Order of Scan

PRODUCT PREVIEW

**data register description**

**boundary-scan register**

The boundary-scan register (BSR) is 44 bits long. It contains one boundary-scan cell (BSC) for each normal-function input pin, one BSC for each normal-function I/O pin (one single cell for both input data and output data), and one BSC for each of the internally decoded output-enable signals (1OEA, 2OEA, 1OEB, 2OEB). The BSR is used 1) to store test data that is to be applied externally to the device output pins, and/or 2) to capture data that appears internally at the outputs of the normal on-chip logic and/or externally at the device input pins.

The source of data to be captured into the BSR during Capture-DR is determined by the current instruction. The contents of the BSR can change during Run-Test/Idle as determined by the current instruction. At power up or in Test-Logic-Reset, BSCs 43–40 are reset to logic 0, ensuring that these cells, which control A-port and B-port outputs, are set to benign values (i.e., if test mode were invoked, the outputs would be at high-impedance state). Reset values of other BSCs should be considered indeterminate.

When external data is to be captured, the BSCs for signals 1OEA, 2OEA, 1OEB, and 2OEB capture logic values determined by the following positive-logic equations:  $1OEA = \overline{1OE} \cdot \overline{1DIR}$ ,  $2OEA = \overline{2OE} \cdot \overline{2DIR}$ ,  $1OEB = \overline{1OE} \cdot \overline{DIR}$ , and  $2OEB = \overline{2OE} \cdot \overline{DIR}$ . When data is to be applied externally, these BSCs control the drive state (active or high impedance) of their respective outputs.

The BSR order of scan is from TDI through bits 43–0 to TDO. Table 1 shows the BSR bits and their associated device pin signals.

**Table 1. Boundary-Scan-Register Configuration**

BSR BIT NUMBER	DEVICE SIGNAL	BSR BIT NUMBER	DEVICE SIGNAL	BSR BIT NUMBER	DEVICE SIGNAL	BSR BIT NUMBER	DEVICE SIGNAL	BSR BIT NUMBER	DEVICE SIGNAL
43	2OEB	35	2A9-I/O	26	1A9-I/O	17	2B9-I/O	8	1B9-I/O
42	1OEB	34	2A8-I/O	25	1A8-I/O	16	2B8-I/O	7	1B8-I/O
41	2OEA	33	2A7-I/O	24	1A7-I/O	15	2B7-I/O	6	1B7-I/O
40	1OEA	32	2A6-I/O	23	1A6-I/O	14	2B6-I/O	5	1B6-I/O
39	2DIR	31	2A5-I/O	22	1A5-I/O	13	2B5-I/O	4	1B5-I/O
38	1DIR	30	2A4-I/O	21	1A4-I/O	12	2B4-I/O	3	1B4-I/O
37	2OE	29	2A3-I/O	20	1A3-I/O	11	2B3-I/O	2	1B3-I/O
36	1OE	28	2A2-I/O	19	1A2-I/O	10	2B2-I/O	1	1B2-I/O
—	—	27	2A1-I/O	18	1A1-I/O	9	2B1-I/O	0	1B1-I/O

**boundary-control register**

The boundary-control register (BCR) is three bits long. The BCR is used in the context of the RUNT instruction to implement additional test operations not included in the basic SCOPE™ instruction set. Such operations include PRPG, PSA, and binary count up (COUNT). Table 4 shows the test operations that are decoded by the BCR.

During Capture-DR, the contents of the BCR are not changed. At power up or in Test-Logic-Reset, the BCR is reset to the binary value 010, which selects the PSA test operation. The BCR order of scan is illustrated in Figure 3.

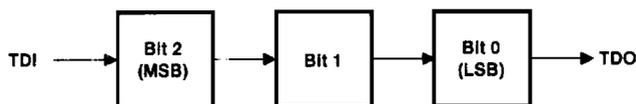

**Figure 3. Boundary-Control Register Order of Scan**

**PRODUCT PREVIEW**

# SN54LVT18640, SN54LVT182640, SN74LVT18640, SN74LVT182640

## 3.3-V ABT SCAN TEST DEVICES

### WITH 18-BIT INVERTING BUS TRANSCEIVERS

SCBS310A – MARCH 1994 – REVISED AUGUST 1994

---

#### bypass register

The bypass register is a 1-bit scan path that can be selected to shorten the length of the system scan path, reducing the number of bits per test pattern that must be applied to complete a test operation. During Capture-DR, the bypass register captures a logic 0. The bypass register order of scan is illustrated in Figure 4.

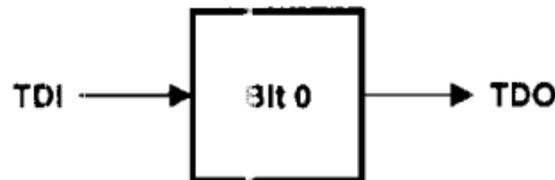

Figure 4. Bypass Register Order of Scan

#### device-identification register

The device-identification register (IDR) is 68 bits long. It can be selected and read to identify the manufacturer

**SN54LVT18640, SN54LVT182640, SN74LVT18640, SN74LVT182640**  
**3.3-V ABT SCAN TEST DEVICES**  
**WITH 18-BIT INVERTING BUS TRANSCEIVERS**  
SCBS310A – MARCH 1994 – REVISED AUGUST 1994

**Instruction-register opcode description**

The instruction-register opcodes are shown in Table 3. The following descriptions detail the operation of each instruction.

**Table 3. Instruction-Register Opcodes**

<b>BINARY CODE† BIT 7 → BIT 0 MSB → LSB</b>	<b>SCOPE OPCODE</b>	<b>DESCRIPTION</b>	<b>SELECTED DATA REGISTER</b>	<b>MODE</b>
00000000	EXTEST	Boundary scan	Boundary scan	Test
10000001	IDCODE	Identification read	Device identification	Normal
10000010	SAMPLE/PRELOAD	Sample boundary	Boundary scan	Normal
00000011	BYPASS‡	Bypass scan	Bypass	Normal
10000100	BYPASS‡	Bypass scan	Bypass	Normal
00000101	BYPASS‡	Bypass scan	Bypass	Normal
00000110	HIGHZ	Control boundary to high impedance	Bypass	Modified test
10000111	CLAMP	Control boundary to 1/0	Bypass	Test
10001000	BYPASS‡	Bypass scan	Bypass	Normal
00001001	RUNT	Boundary run test	Bypass	Test
00001010	READBN	Boundary read	Boundary scan	Normal
10001011	READBT	Boundary read	Boundary scan	Test
00001100	CELLTST	Boundary self test	Boundary scan	Normal
10001101	TOPHIP	Boundary toggle outputs	Bypass	Test
10001110	SCANCN	Boundary-control register scan	Boundary control	Normal
00001111	SCANCT	Boundary-control register scan	Boundary control	Test
All others	BYPASS	Bypass scan	Bypass	Normal

† Bit 7 is used to maintain even parity in the 8-bit instruction.

‡ The BYPASS instruction is executed in lieu of a SCOPE™ instruction that is not supported in the LVT18640 and LVT182640.

**boundary scan**

This instruction conforms to the IEEE Standard 1149.1-1990 EXTEST instruction. The BSR is selected in the scan path. Data appearing at the device input and I/O pins is captured in the associated BSCs. Data that has been scanned into the input BSCs is applied to the inputs of the normal on-chip logic, while data scanned into the I/O BSCs for pins in the output mode is applied to the device I/O pins. Data present at the device I/O pins is passed through the I/O BSCs to the normal on-chip logic. For I/O pins, the operation of a pin as input or output is determined by the contents of the output-enable BSCs (bits 43–40 of the BSR). When a given output enable is active (logic 1), the associated I/O pins operate in the output mode. Otherwise, the I/O pins operate in the input mode. The device operates in the test mode.

**identification read**

This instruction conforms to the IEEE Standard 1149.1-1990 IDCODE instruction. The IDR is selected in the scan path. The device operates in the normal mode.

**sample boundary**

This instruction conforms to the IEEE Standard 1149.1-1990 SAMPLE/PRELOAD instruction. The BSR is selected in the scan path. Data appearing at the device input pins and I/O pins in the input mode is captured in the associated BSCs, while data appearing at the outputs of the normal on-chip logic is captured in the BSCs associated with I/O pins in the output mode. The device operates in the normal mode.

**PRODUCT PREVIEW**



**SN54LVT18640, SN54LVT182640, SN74LVT18640, SN74LVT182640**  
**3.3-V ABT SCAN TEST DEVICES**  
**WITH 18-BIT INVERTING BUS TRANSCEIVERS**

SCBS310A – MARCH 1994 – REVISED AUGUST 1994

---

**bypass scan**

This instruction conforms to the IEEE Standard 1149.1-1990 BYPASS instruction. The bypass register is selected in the scan path. A logic 0 value is captured in the bypass register during Capture-DR. The device operates in the normal mode.

**control boundary to high impedance**

This instruction conforms to the IEEE Standard 1149.1a-1993 HIGHZ instruction. The bypass register is selected in the scan path. A logic 0 value is captured in the bypass register during Capture-DR. The device operates in a modified test mode in which all device I/O pins are placed in the high-impedance state, the device input pins remain operational, and the normal on-chip logic function is performed.

**control boundary to 1/0**

This instruction conforms to the IEEE Standard 1149.1a-1993 CLAMP instruction. The bypass register is selected in the scan path. A logic 0 value is captured in the bypass register during Capture-DR. Data in the input BSCs is applied to the inputs of the normal on-chip logic, while data in the I/O BSCs for pins in the output mode is applied to the device I/O pins. The device operates in the test mode.

**boundary-run test**

The bypass register is selected in the scan path. A logic 0 value is captured in the bypass register during Capture-DR. The device operates in the test mode. The test operation specified in the BCR is executed during Run-Test/Idle. The five test operations decoded by the BCR are: sample inputs/toggle outputs (TOPSIP), PRPG, PSA, simultaneous PSA and PRPG (PSA/PRPG), and simultaneous PSA and binary count up (PSA/COUNT).

**boundary read**

The BSR is selected in the scan path. The value in the BSR remains unchanged during Capture-DR. This instruction is useful for inspecting data after a PSA operation.

**boundary self test**

The BSR is selected in the scan path. All BSCs capture the inverse of their current values during Capture-DR. In this way, the contents of the shadow latches can be read out to verify the integrity of both shift-register and shadow-latch elements of the BSR. The device operates in the normal mode.

**boundary toggle outputs**

The bypass register is selected in the scan path. A logic 0 value is captured in the bypass register during Capture-DR. Data in the shift-register elements of the selected output-mode BSCs is toggled on each rising edge of TCK in Run-Test/Idle, updated in the shadow latches, and applied to the associated device I/O pins on each falling edge of TCK in Run-Test/Idle. Data in the input-mode BSCs remains constant. Data appearing at the device input or I/O pins is not captured in the input-mode BSCs. The device operates in the test mode.

**boundary-control-register scan**

The BCR is selected in the scan path. The value in the BCR remains unchanged during Capture-DR. This operation must be performed before a boundary-run test operation to specify which test operation is to be executed.

PRODUCT PREVIEW



**boundary-control-register opcode description**

The BCR opcodes are decoded from BCR bits 2–0 as shown in Table 4. The selected test operation is performed while the RUNT instruction is executed in the Run-Test/Idle state. The following descriptions detail the operation of each BCR instruction and illustrate the associated PSA and PRPG algorithms.

**Table 4. Boundary-Control-Register Opcodes**

BINARY CODE BIT 2 → BIT 0 MSB → LSB	DESCRIPTION
X00	Sample inputs/toggle outputs (TOPSIP)
X01	Pseudo-random pattern generation/36-bit mode (PRPG)
X10	Parallel-signature analysis/36-bit mode (PSA)
011	Simultaneous PSA and PRPG/18-bit mode (PSA/PRPG)
111	Simultaneous PSA and binary count up/18-bit mode (PSA/COUNT)

While the control input BSCs (bits 43–36) are not included in the toggle, PSA, PRPG, or COUNT algorithms, the output-enable BSCs (bits 43–40 of the BSR) control the drive state (active or high impedance) of the selected device output pins. These BCR instructions are valid only when both bytes of the device are operating in one direction of data flow (that is, 1OEA ≠ 1OEB and 2OEA ≠ 2OEB) and in the same direction of data flow (that is, 1OEA = 2OEA and 1OEB = 2OEB). Otherwise, the bypass instruction is operated.

**sample inputs/toggle outputs (TOPSIP)**

Data appearing at the selected device input-mode I/O pins is captured in the shift-register elements of the associated BSCs on each rising edge of TCK. Data in the shift-register elements of the selected output-mode BSCs is toggled on each rising edge of TCK, updated in the shadow latches, and applied to the associated device I/O pins on each falling edge of TCK.

**PRODUCT PREVIEW**

**SN54LVT18640, SN54LVT182640, SN74LVT18640, SN74LVT182640**  
**3.3-V ABT SCAN TEST DEVICES**  
**WITH 18-BIT INVERTING BUS TRANSCEIVERS**

SCBS310A – MARCH 1994 – REVISED AUGUST 1994

**pseudo-random pattern generation (PRPG)**

A pseudo-random pattern is generated in the shift-register elements of the selected BSCs on each rising edge of TCK, updated in the shadow latches, and applied to the associated device output-mode I/O pins on each falling edge of TCK. Figures 5 and 6 illustrate the 36-bit linear-feedback shift-register algorithms through which the patterns are generated. An initial seed value should be scanned into the BSR before performing this operation. A seed value of all zeroes does not produce additional patterns.

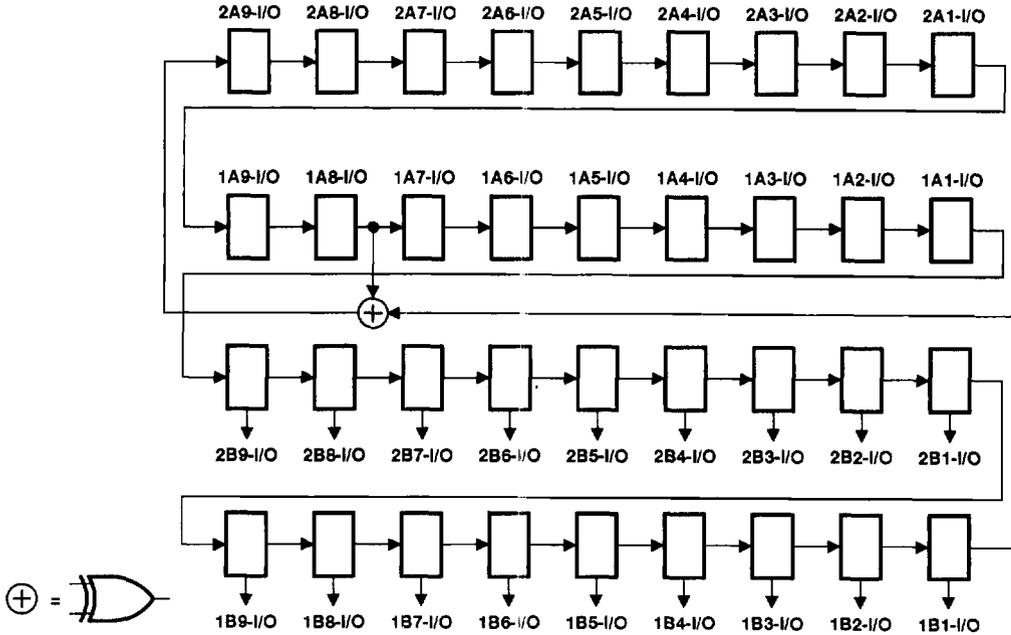

Figure 5. 36-Bit PRPG Configuration (10EA = 20EA = 0, 10EB = 20EB = 1)

PRODUCT PREVIEW

SN54LVT18640, SN54LVT182640, SN74LVT18640, SN74LVT182640  
 3.3-V ABT SCAN TEST DEVICES  
 WITH 18-BIT INVERTING BUS TRANSCEIVERS  
 SCBS310A - MARCH 1994 - REVISED AUGUST 1994

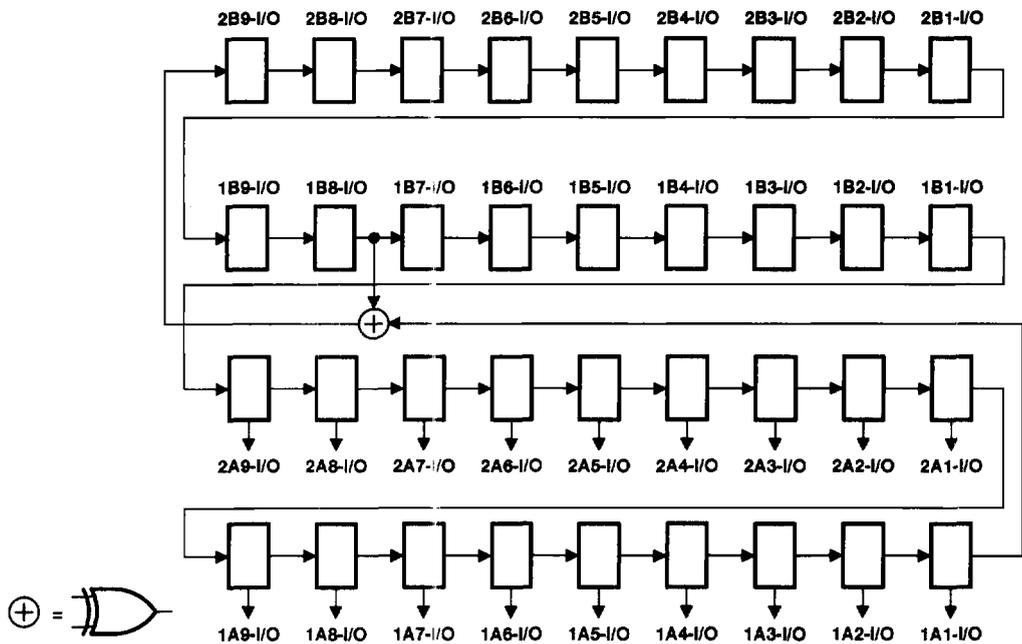

Figure 6. 36-Bit PRPG Configuration (10EA = 20EA = 1, 10EB = 20EB = 0)

PRODUCT PREVIEW

**SN54LVT18640, SN54LVT182640, SN74LVT18640, SN74LVT182640**  
**3.3-V ABT SCAN TEST DEVICES**  
**WITH 18-BIT INVERTING BUS TRANSCEIVERS**

SCBS310A – MARCH 1994 – REVISED AUGUST 1994

**parallel-signature analysis (PSA)**

Data appearing at the selected device input-mode I/O pins is compressed into a 36-bit parallel signature in the shift-register elements of the selected BSCs on each rising edge of TCK. Data in the shadow latches of the selected output-mode BSCs remains constant and is applied to the associated device I/O pins. Figures 7 and 8 illustrate the 36-bit linear-feedback shift-register algorithms through which the signature is generated. An initial seed value should be scanned into the BSR before performing this operation.

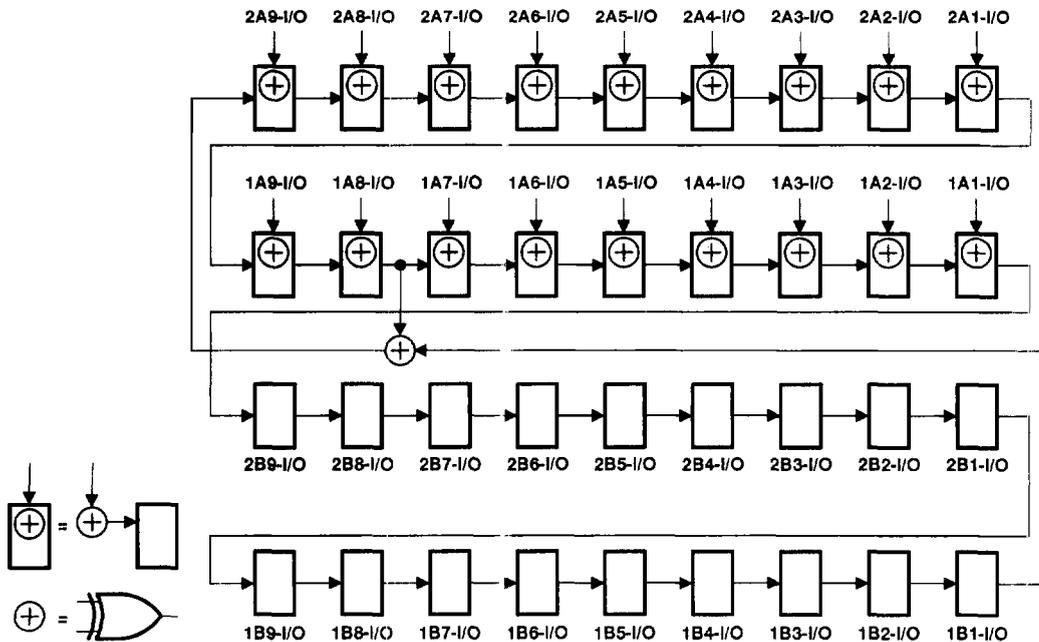

Figure 7. 36-Bit PSA Configuration (1OEA = 2OEA = 0, 1OEB = 2OEB = 1)

PRODUCT PREVIEW

SN54LVT18640, SN54LVT182640, SN74LVT18640, SN74LVT182640  
 3.3-V ABT SCAN TEST DEVICES  
 WITH 18-BIT INVERTING BUS TRANSCEIVERS

SCBS310A - MARCH 1994 - REVISED AUGUST 1994

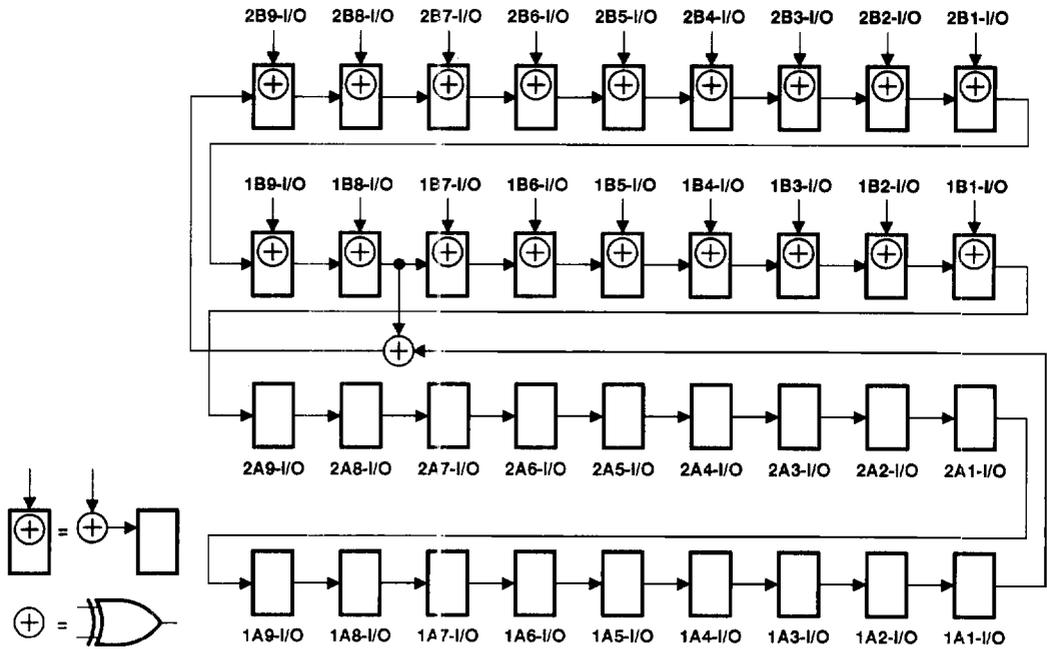

Figure 8. 36-Bit PSA Configuration (10EA = 20EA = 1, 10EB = 20EB = 0)

PRODUCT PREVIEW

**SN54LVT18640, SN54LVT182640, SN74LVT18640, SN74LVT182640**  
**3.3-V ABT SCAN TEST DEVICES**  
**WITH 18-BIT INVERTING BUS TRANSCEIVERS**

SCBS310A – MARCH 1994 – REVISED AUGUST 1994

**simultaneous PSA and PRPG (PSA/PRPG)**

Data appearing at the selected device input-mode I/O pins is compressed into an 18-bit parallel signature in the shift-register elements of the selected input-mode BSCs on each rising edge of TCK. At the same time, an 18-bit pseudo-random pattern is generated in the shift-register elements of the selected output-mode BSCs on each rising edge of TCK, updated in the shadow latches, and applied to the associated device I/O pins on each falling edge of TCK. Figures 9 and 10 illustrate the 18-bit linear-feedback shift-register algorithms through which the signature and patterns are generated. An initial seed value should be scanned into the BSR before performing this operation. A seed value of all zeroes does not produce additional patterns.

PRODUCT PREVIEW

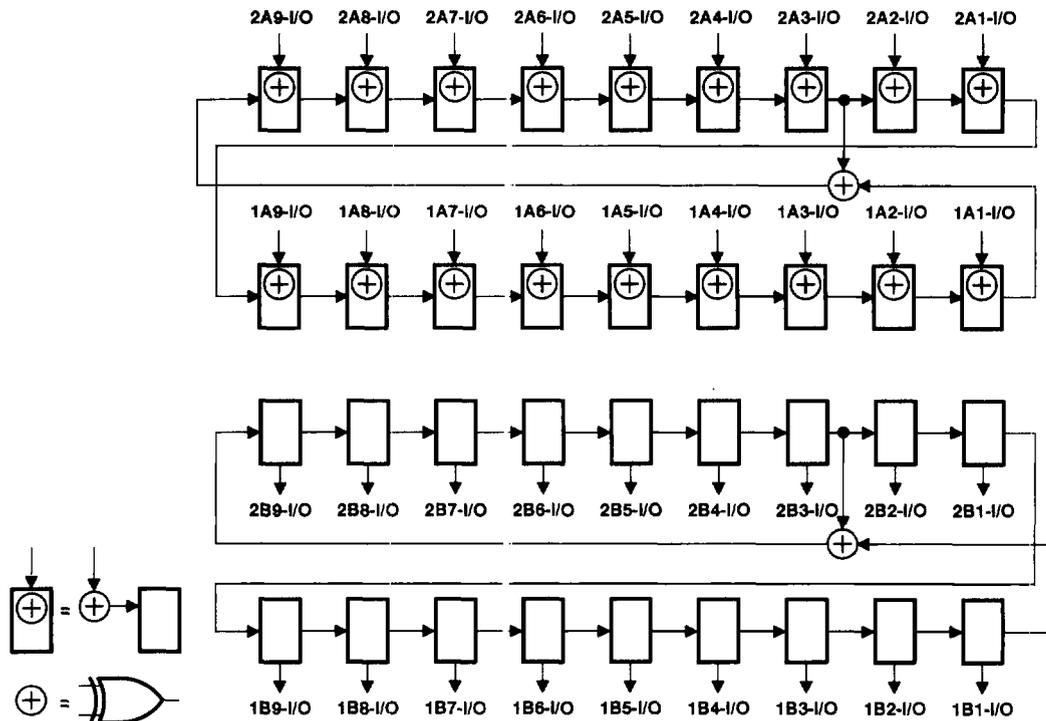

Figure 9. 18-Bit PSA/PRPG Configuration (10EA = 20EA = 0, 10EB = 20EB = 1)



**SN54LVT18640, SN54LVT182640, SN74LVT18640, SN74LVT182640**  
**3.3-V ABT SCAN TEST DEVICES**  
**WITH 18-BIT INVERTING BUS TRANSCEIVERS**  
SCBS310A – MARCH 1994 – REVISED AUGUST 1994

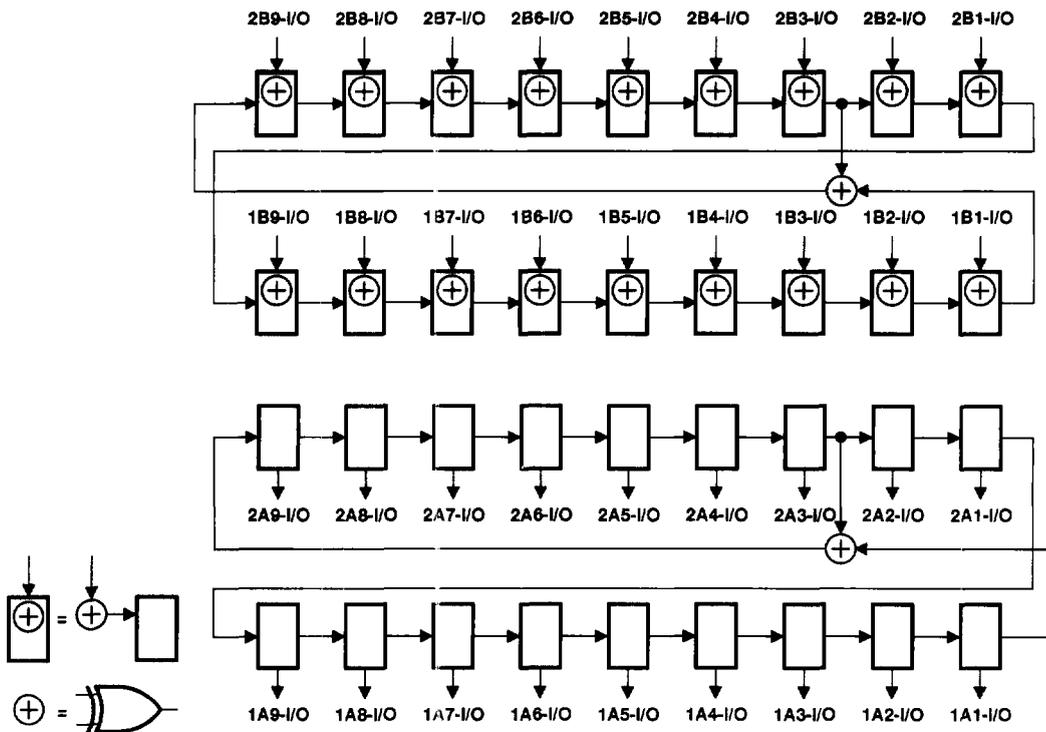

Figure 10. 18-Bit PSA/PRPG Configuration (1OEA = 2OEA = 1, 1OEB = 2OEB = 0)

**PRODUCT PREVIEW**

**3.3-V ABT SCAN TEST DEVICES  
WITH 18-BIT INVERTING BUS TRANSCEIVERS**

SCBS310A - MARCH 1994 - REVISED AUGUST 1994

**simultaneous PSA and binary count up (PSA/COUNT)**

Data appearing at the selected device input-mode I/O pins is compressed into an 18-bit parallel signature in the shift-register elements of the selected input-mode BSCs on each rising edge of TCK. At the same time, an 18-bit binary count-up pattern is generated in the shift-register elements of the selected output-mode BSCs on each rising edge of TCK, updated in the shadow latches, and applied to the associated device I/O pins on each falling edge of TCK. Figures 11 and 12 illustrate the 18-bit linear-feedback shift-register algorithms through which the signature is generated. An initial seed value should be scanned into the BSR before performing this operation.

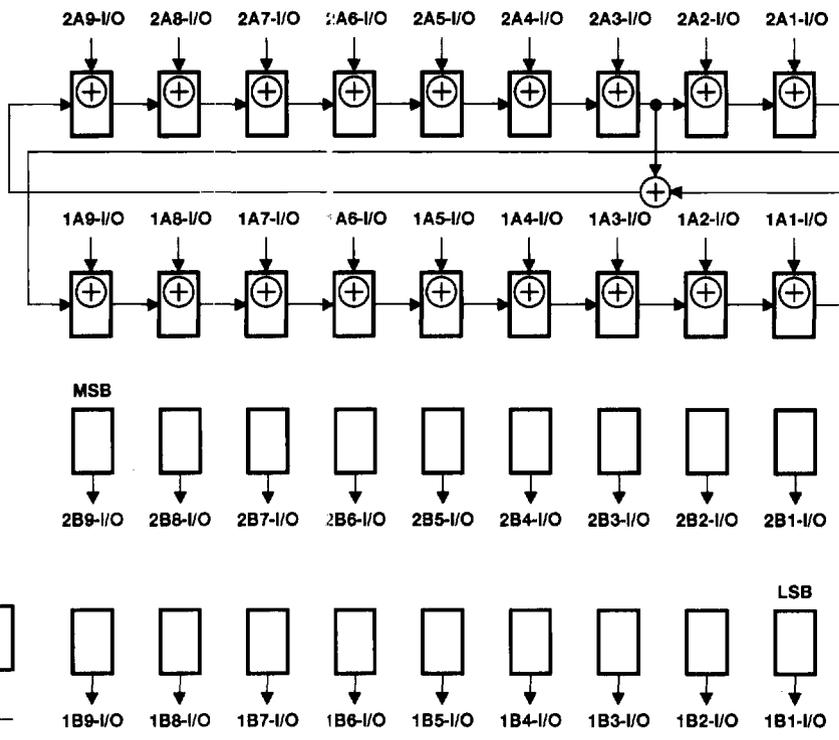

Figure 11. 18-Bit PSA/COUNT Configuration (10EA = 20EA = 0, 10EB = 20EB = 1)

PRODUCT PREVIEW

**SN54LVT18640, SN54LVT182640, SN74LVT18640, SN74LVT182640**  
**3.3-V ABT SCAN TEST DEVICES**  
**WITH 18-BIT INVERTING BUS TRANSCEIVERS**

SCBS310A - MARCH 1994 - REVISED AUGUST 1994

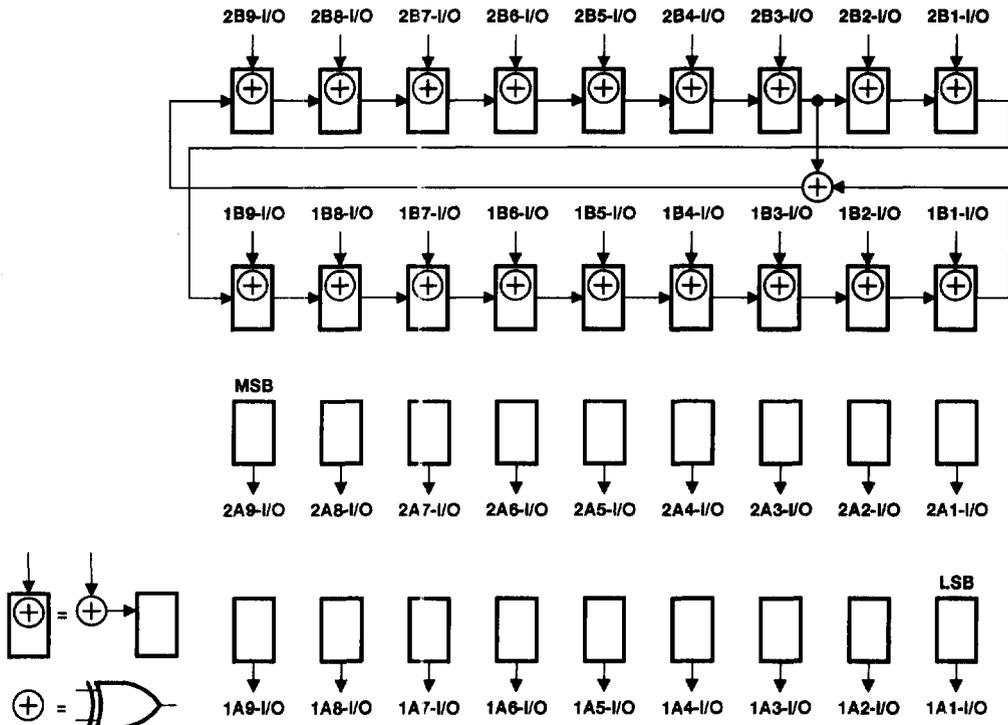

Figure 12. 18-Bit PSA/COUNT Configuration (1OEA = 2OEA = 1, 1OEB = 2OEB = 0)

**PRODUCT PREVIEW**

# SN54LVT18640, SN54LVT182640, SN74LVT18640, SN74LVT182640

## 3.3-V ABT SCAN TEST DEVICES WITH 18-BIT INVERTING BUS TRANSCEIVERS

SCBS310A – MARCH 1994 – REVISED AUGUST 1994

### timing description

All test operations of the LVT18640 and LVT182640 are synchronous to TCK. Data on the TDI, TMS, and normal-function inputs is captured on the rising edge of TCK. Data appears on the TDO and normal-function output pins on the falling edge of TCK. The TAP controller is advanced through its states (as illustrated in Figure 1) by changing the value of TMS on the falling edge of TCK and then applying a rising edge to TCK.

A simple timing example is illustrated in Figure 13. In this example, the TAP controller begins in the Test-Logic-Reset state and is advanced through its states as necessary to perform one instruction-register scan and one data-register scan. While in the Shift-IR and Shift-DR states, TDI is used to input serial data, and TDO is used to output serial data. The TAP controller is then returned to the Test-Logic-Reset state. Table 5 explains the operation of the test circuitry during each TCK cycle.

**Table 5. Explanation of Timing Example**

TCK CYCLE(S)	TAP STATE AFTER TCK	DESCRIPTION
1	Test-Logic-Reset	TMS is changed to a logic 0 value on the falling edge of TCK to begin advancing the TAP controller toward the desired state.
2	Run-Test/Idle	
3	Select-DR-Scan	
4	Select-IR-Scan	
5	Capture-IR	The IR captures the 8-bit binary value 10000001 on the rising edge of TCK as the TAP controller exits the Capture-IR state.
6	Shift-IR	TDO becomes active and TDI is made valid on the falling edge of TCK. The first bit is shifted into the TAP on the rising edge of TCK as the TAP controller advances to the next state.
7-13	Shift-IR	One bit is shifted into the IR on each TCK rising edge. With TDI held at a logic 1 value, the 8-bit binary value 11111111 is serially scanned into the IR. At the same time, the 8-bit binary value 10000001 is serially scanned out of the IR via TDO. In TCK cycle 13, TMS is changed to a logic 1 value to end the IR scan on the next TCK cycle. The last bit of the instruction is shifted as the TAP controller advances from Shift-IR to Exit1-IR.
14	Exit1-IR	TDO becomes inactive (goes to the high-impedance state) on the falling edge of TCK.
15	Update-IR	The IR is updated with the new instruction (BYPASS) on the falling edge of TCK.
16	Select-DR-Scan	
17	Capture-DR	The bypass register captures a logic 0 value on the rising edge of TCK as the TAP controller exits the Capture-DR state.
18	Shift-DR	TDO becomes active and TDI is made valid on the falling edge of TCK. The first bit is shifted into the TAP on the rising edge of TCK as the TAP controller advances to the next state.
19-20	Shift-DR	The binary value 101 is shifted in via TDI, while the binary value 010 is shifted out via TDO.
21	Exit1-DR	TDO becomes inactive (goes to the high-impedance state) on the falling edge of TCK.
22	Update-DR	In general, the selected data register is updated with the new data on the falling edge of TCK.
23	Select-DR-Scan	
24	Select-IR-Scan	
25	Test-Logic-Reset	Test operation completed

PRODUCT PREVIEW



**SN54LVT18640, SN54LVT182640, SN74LVT18640, SN74LVT182640**  
**3.3-V ABT SCAN TEST DEVICES**  
**WITH 18-BIT INVERTING BUS TRANSCEIVERS**  
 SCBS310A – MARCH 1994 – REVISED AUGUST 1994

**timing description (continued)**

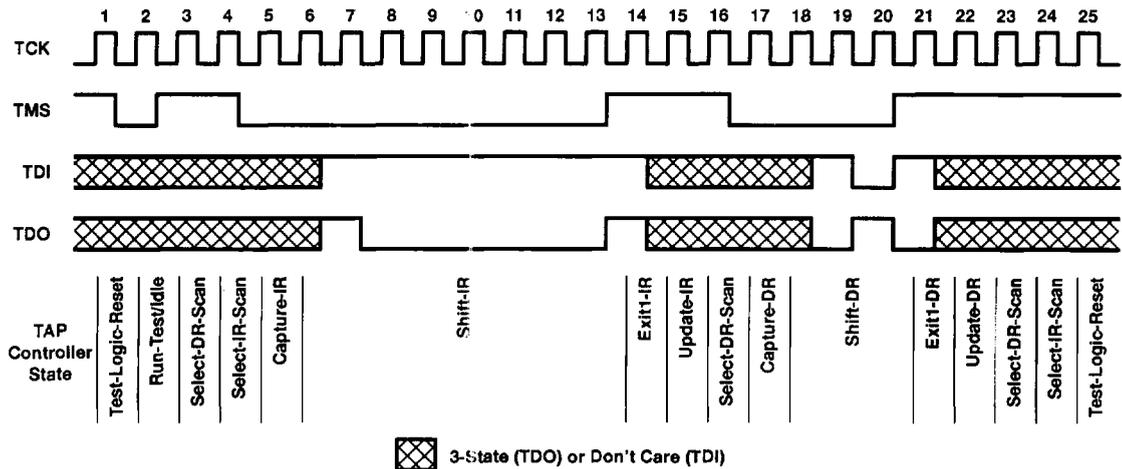

**Figure 13. Timing Example**

**absolute maximum ratings over operating free-air temperature range (unless otherwise noted)†**

Supply voltage range, $V_{CC}$ .....	-0.5 V to 4.6 V
Input voltage range, $V_I$ (see Note 1) .....	-0.5 V to 7 V
Voltage range applied to any output in the high state or power-off state, $V_O$ (see Note 1) .....	-0.5 V to 7 V
Current into any output in the low state, $I_O$ : SN54LVT18640 .....	96 mA
SN54LVT182640 (A port or TDO) .....	96 mA
SN54LVT182640 (B port) .....	30 mA
SN74LVT18640 .....	128 mA
SN74LVT182640 (A port or TDO) .....	128 mA
SN74LVT182640 (B port) .....	30 mA
Current into any output in the high state, $I_O$ (see Note 2): SN54LVT18640 .....	48 mA
SN54LVT182640 (A port or TDO) .....	48 mA
SN54LVT182640 (B port) .....	30 mA
SN74LVT18640 .....	64 mA
SN74LVT182640 (A port or TDO) .....	64 mA
SN74LVT182640 (B port) .....	30 mA
Input clamp current, $I_{IK}$ ( $V_I < 0$ ) .....	-50 mA
Output clamp current, $I_{OK}$ ( $V_O < 0$ ) .....	-50 mA
Maximum power dissipation at $T_A = 55^\circ\text{C}$ (in still air): DGG package .....	1 W
DL package .....	1.4 W
Storage temperature range .....	-65°C to 150°C

† Stresses beyond those listed under "absolute maximum ratings" may cause permanent damage to the device. These are stress ratings only, and functional operation of the device at these or any other conditions beyond those indicated under "recommended operating conditions" is not implied. Exposure to absolute-maximum-rated conditions for extended periods may affect device reliability.

- NOTES: 1. The input and output negative-voltage ratings can be exceeded if the input and output clamp-current ratings are observed.  
 2. This current will only flow when the output is in the high state and  $V_O > V_{CC}$ .

**PRODUCT PREVIEW**

**SN54LVT18640, SN54LVT182640, SN74LVT18640, SN74LVT182640**  
**3.3-V ABT SCAN TEST DEVICES**  
**WITH 18-BIT INVERTING BUS TRANSCEIVERS**

SCBS310A – MARCH 1994 – REVISED AUGUST 1994

**recommended operating conditions**

		SN54LVT18640		SN74LVT18640		UNIT
		MIN	MAX	MIN	MAX	
$V_{CC}$	Supply voltage	2.7	3.6	2.7	3.6	V
$V_{IH}$	High-level input voltage	2		2		V
$V_{IL}$	Low-level input voltage	0.8		0.8		V
$V_I$	Input voltage	5.5		5.5		V
$I_{OH}$	High-level output current	-24		-32		mA
$I_{OL}$	Low-level output current	24		32		mA
$I_{OL}^{\dagger}$	Low-level output current	48		64		mA
$\Delta t/\Delta v$	Input transition rise or fall rate	10		10		ns/V
$T_A$	Operating free-air temperature	-55	125	-40	85	°C

† Current duty cycle  $\leq 50\%$ ,  $f \geq 1$  kHz

**PRODUCT PREVIEW**



**SN54LVT18640, SN54LVT182640, SN74LVT18640, SN74LVT182640**  
**3.3-V ABT SCAN TEST DEVICES**  
**WITH 18-BIT INVERTING BUS TRANSCEIVERS**

SCBS310A - MARCH 1994 - REVISED AUGUST 1994

**electrical characteristics over recommended operating free-air temperature range (unless otherwise noted) (see Note 3)**

PARAMETER	TEST CONDITIONS		SN54LVT18640			SN74LVT18640			UNIT
			MIN	TYPT†	MAX	MIN	TYPT†	MAX	
$V_{IK}$	$V_{CC} = 2.7 \text{ V}$ , $I_I = -18 \text{ mA}$		-1.2			-1.2			V
$V_{OH}$	$V_{CC} = \text{MIN to MAX}^\ddagger$ , $I_{OH} = -100 \mu\text{A}$		$V_{CC} - 0.2$			$V_{CC} - 0.2$			V
	$V_{CC} = 2.7 \text{ V}$ , $I_{OH} = -3 \text{ mA}$		2.4			2.4			
	$V_{CC} = 3 \text{ V}$	$I_{OH} = -8 \text{ mA}$	2.4			2.4			
		$I_{OH} = -24 \text{ mA}$	2						
$V_{OL}$	$V_{CC} = 2.7 \text{ V}$	$I_{OL} = 100 \mu\text{A}$				0.2			V
		$I_{OL} = 24 \text{ mA}$				0.5			
	$V_{CC} = 3 \text{ V}$	$I_{OL} = 16 \text{ mA}$				0.4			
		$I_{OL} = 32 \text{ mA}$				0.5			
		$I_{OL} = 48 \text{ mA}$				0.55			
		$I_{OL} = 64 \text{ mA}$				0.55			
$I_I$	$V_{CC} = 3.6 \text{ V}$ , $V_I = V_{CC} \text{ or GND}$		DIR, TCK	$\pm 1$		$\pm 1$		$\mu\text{A}$	
	$V_{CC} = 0 \text{ or MAX}^\ddagger$ , $V_I = 5.5 \text{ V}$			10		10			
	$V_{CC} = 3.6 \text{ V}$	$V_I = 5.5 \text{ V}$	OE, TDI, TMS	50		50			
		$V_I = V_{CC}$		1		1			
		$V_I = 0$		-100		-100			
		$V_I = 5.5 \text{ V}$	A or B ports§	20		20			
		$V_I = V_{CC}$		1		1			
		$V_I = 0$		-5		-5			
$I_{off}$	$V_{CC} = 0$ , $V_I \text{ or } V_O = 0 \text{ to } 4.5 \text{ V}$				$\pm 100$		$\mu\text{A}$		
$I_{I(\text{hold})}$	$V_{CC} = 3 \text{ V}$	$V_I = 0.8 \text{ V}$	A or B ports	75		75		$\mu\text{A}$	
		$V_I = 2 \text{ V}$		-75		-75			
$I_{OZH}$	$V_{CC} = 3.6 \text{ V}$ , $V_O = 3 \text{ V}$		1		1		$\mu\text{A}$		
$I_{OZL}$	$V_{CC} = 3.6 \text{ V}$ , $V_O = 0.5 \text{ V}$		-1		-1		$\mu\text{A}$		
$I_{CC}$	$V_{CC} = 3.6 \text{ V}$ , $V_I = V_{CC} \text{ or GND}$ , $I_O = 0$		Outputs high	2		2		mA	
			Outputs low	30		30			
			Outputs disabled	2		2			
$\Delta I_{CC}^\parallel$	$V_{CC} = 3 \text{ V to } 3.6 \text{ V}$ , One input at $V_{CC} - 0.6 \text{ V}$ , Other inputs at $V_{CC} \text{ or GND}$		0.2		0.2		mA		
$C_i$	$V_I = 3 \text{ V or } 0$		4		4		pF		
$C_{io}$	$V_O = 3 \text{ V or } 0$		11		11		pF		
$C_o$	$V_O = 3 \text{ V or } 0$		8		8		pF		

† All typical values are at  $V_{CC} = 3.3 \text{ V}$ ,  $T_A = 25^\circ\text{C}$ .

‡ For conditions shown as MIN or MAX, use the appropriate value specified under recommended operating conditions.

§ Unused pins at  $V_{CC}$  or GND

¶ This is the increase in supply current for each input that is at the specified TTL voltage level rather than  $V_{CC}$  or GND.

NOTE 3: Product preview specifications are design goals only and are subject to change without notice.

**PRODUCT PREVIEW**



SN54LVT18640, SN54LVT182640, SN74LVT18640, SN74LVT182640

3.3-V ABT SCAN TEST DEVICES

WITH 18-BIT INVERTING BUS TRANSCEIVERS

SCBS310A - MARCH 1994 - REVISED AUGUST 1994

timing requirements over recommended operating free-air temperature range (unless otherwise noted) (test mode) (see Note 3 and Figure 14)

			SN54LVT18640				SN74LVT18640				UNIT
			V <sub>CC</sub> = 3.3 V ± 0.3 V		V <sub>CC</sub> = 2.7 V		V <sub>CC</sub> = 3.3 V ± 0.3 V		V <sub>CC</sub> = 2.7 V		
			MIN	MAX	MIN	MAX	MIN	MAX	MIN	MAX	
f <sub>clock</sub>	Clock frequency	TCK				0	20			MHz	
t <sub>w</sub>	Pulse duration	TCK high or low				25				ns	
t <sub>su</sub>	Setup time	A, B, DIR, or $\overline{OE}$ before TCK↑				8				ns	
		TDI before TCK↑				8					
		TMS before TCK↑				6					
t <sub>h</sub>	Hold time	A, B, DIR, or $\overline{OE}$ after TCK↑				1				ns	
		TDI after TCK↑				1					
		TMS after TCK↑				1					
t <sub>d</sub>	Delay time	Power up to TCK↑				50				ns	
t <sub>r</sub>	Rise time	V <sub>CC</sub> power up				1				μs	

NOTE 3: Product preview specifications are design goals only and are subject to change without notice.

PRODUCT PREVIEW



**SN54LVT18640, SN54LVT182640, SN74LVT18640, SN74LVT182640**  
**3.3-V ABT SCAN TEST DEVICES**  
**WITH 18-BIT INVERTING BUS TRANSCEIVERS**

SCBS310A - MARCH 1994 - REVISED AUGUST 1994

**switching characteristics over recommended operating free-air temperature range (unless otherwise noted) (normal mode) (see Note 3 and Figure 14)**

PARAMETER	FROM (INPUT)	TO (OUTPUT)	SN54LVT18640				SN74LVT18640				UNIT
			V <sub>CC</sub> = 3.3 V ± 0.3 V		V <sub>CC</sub> = 2.7 V		V <sub>CC</sub> = 3.3 V ± 0.3 V		V <sub>CC</sub> = 2.7 V		
			MIN	MAX	MIN	MAX	MIN	MAX	MIN	MAX	
t <sub>PLH</sub>	A or B	B or A					1.5	7		ns	
t <sub>PHL</sub>							1.5	7			
t <sub>PZH</sub>	OE	B or A					3	9		ns	
t <sub>PZL</sub>							3	9			
t <sub>PHZ</sub>	OE	B or A					3	9.5		ns	
t <sub>PLZ</sub>							3	9.5			

**switching characteristics over recommended operating free-air temperature range (unless otherwise noted) (test mode) (see Note 3 and Figure 14)**

PARAMETER	FROM (INPUT)	TO (OUTPUT)	SN54LVT18640				SN74LVT18640				UNIT
			V <sub>CC</sub> = 3.3 V ± 0.3 V		V <sub>CC</sub> = 2.7 V		V <sub>CC</sub> = 3.3 V ± 0.3 V		V <sub>CC</sub> = 2.7 V		
			MIN	MAX	MIN	MAX	MIN	MAX	MIN	MAX	
f <sub>max</sub>	TCK↓							20		MHz	
t <sub>PLH</sub>	TCK↓	A or B					3	22		ns	
t <sub>PHL</sub>							3	22			
t <sub>PLH</sub>	TCK↓	TDO					2	12		ns	
t <sub>PHL</sub>							2	12			
t <sub>PZH</sub>	TCK↓	A or B					3	22		ns	
t <sub>PZL</sub>							3	22			
t <sub>PZH</sub>	TCK↓	TDO					2	12		ns	
t <sub>PZL</sub>							2	12			
t <sub>PHZ</sub>	TCK↓	A or B					3	22		ns	
t <sub>PLZ</sub>							3	22			
t <sub>PHZ</sub>	TCK↓	TDO					2	15		ns	
t <sub>PLZ</sub>							2	15			

NOTE 3: Product preview specifications are design goals only and are subject to change without notice.

**PRODUCT PREVIEW**



**SN54LVT18640, SN54LVT182640, SN74LVT18640, SN74LVT182640**  
**3.3-V ABT SCAN TEST DEVICES**  
**WITH 18-BIT INVERTING BUS TRANSCEIVERS**

SCBS310A – MARCH 1994 – REVISED AUGUST 1994

**recommended operating conditions**

		SN54LVT182640		SN74LVT182640		UNIT
		MIN	MAX	MIN	MAX	
$V_{CC}$	Supply voltage	2.7	3.6	2.7	3.6	V
$V_{IH}$	High-level input voltage	2		2		V
$V_{IL}$	Low-level input voltage		0.8		0.8	V
$V_I$	Input voltage		5.5		5.5	V
$I_{OH}$	High-level output current	A port or TDO		-24	-32	mA
		B port		-12	-12	mA
$I_{OL}$	Low-level output current	A port or TDO		24	32	mA
		B port		12	12	mA
$I_{OL}^{\dagger}$	Low-level output current	A port or TDO		48	64	mA
$\Delta t/\Delta v$	Input transition rise or fall rate	Outputs enabled		10	10	ns/V
$T_A$	Operating free-air temperature	-55	125	-40	85	°C

† Current duty cycle  $\leq 50\%$ ,  $f \geq 1$  kHz

PRODUCT PREVIEW



**SN54LVT18640, SN54LVT182640, SN74LVT18640, SN74LVT182640**  
**3.3-V ABT SCAN TEST DEVICES**  
**WITH 18-BIT INVERTING BUS TRANSCEIVERS**

SCBS310A – MARCH 1994 – REVISED AUGUST 1994

**electrical characteristics over recommended operating free-air temperature range (unless otherwise noted) (see Note 3)**

PARAMETER	TEST CONDITIONS		SN54LVT182640			SN74LVT182640			UNIT
			MIN	TYP†	MAX	MIN	TYP†	MAX	
$V_{IK}$	$V_{CC} = 2.7\text{ V}$ ,	$I_I = -18\text{ mA}$			-1.2			-1.2	V
$V_{OH}$	$V_{CC} = \text{MIN to MAX}^\ddagger$ ,	$I_{OH} = -100\ \mu\text{A}$	A port, TDO	$V_{CC} - 0.2$		$V_{CC} - 0.2$			V
				$V_{CC} = 2.7\text{ V}$ ,	$I_{OH} = -3\text{ mA}$	2.4		2.4	
	$V_{CC} = 3\text{ V}$	$I_{OH} = -8\text{ mA}$		2.4		2.4			
				$I_{OH} = -24\text{ mA}$	2				
				$I_{OH} = -32\text{ mA}$			2		
				$I_{OH} = -12\text{ mA}$			2		
$V_{OL}$	$V_{CC} = 2.7\text{ V}$	$I_{OL} = 100\ \mu\text{A}$	A port, TDO			0.2		0.2	V
		$I_{OL} = 24\text{ mA}$				0.5		0.5	
	$V_{CC} = 3\text{ V}$	$I_{OL} = 16\text{ mA}$		0.4		0.4			
		$I_{OL} = 32\text{ mA}$				0.5		0.5	
		$I_{OL} = 48\text{ mA}$				0.55			
		$I_{OL} = 64\text{ mA}$						0.55	
		$I_{OL} = 12\text{ mA}$	B port			0.8		0.8	
	$I_I$	$V_{CC} = 3.6\text{ V}$ ,	$V_I = V_{CC}\text{ or GND}$	DIR, TCK		$\pm 1$		$\pm 1$	
$V_{CC} = 0\text{ or MAX}^\ddagger$ ,		$V_I = 5.5\text{ V}$			10		10		
$V_{CC} = 3.6\text{ V}$		$V_I = 5.5\text{ V}$	$\overline{\text{OE}}$ , TDI, TMS			50		50	
		$V_I = V_{CC}$				1		1	
		$V_I = 0$				-100		-100	
		$V_I = 5.5\text{ V}$				20		20	
		$V_I = V_{CC}$	A or B ports§			1		1	
$V_I = 0$				-5		-5			
$I_{off}$	$V_{CC} = 0$ ,	$V_I\text{ or }V_O = 0\text{ to }4.5\text{ V}$					$\pm 100$	$\mu\text{A}$	
$I_I(\text{hold})$	$V_{CC} = 3\text{ V}$	$V_I = 0.8\text{ V}$	A or B ports		75		75	$\mu\text{A}$	
		$V_I = 2\text{ V}$			-75		-75		
$I_{OZH}$	$V_{CC} = 3.6\text{ V}$ ,	$V_O = 3\text{ V}$			1		1	$\mu\text{A}$	
$I_{OZL}$	$V_{CC} = 3.6\text{ V}$ ,	$V_O = 0.5\text{ V}$			-1		-1	$\mu\text{A}$	
$I_{CC}$	$V_{CC} = 3.6\text{ V}$ ,	$V_I = V_{CC}\text{ or GND}$	$I_O = 0$ ,	Outputs high		2		2	mA
				Outputs low		35		35	
				Outputs disabled		2		2	
$\Delta I_{CC}^\ddagger$	$V_{CC} = 3\text{ V to }3.6\text{ V}$ ,	One input at $V_{CC}$ ; -0.6 V, Other inputs at $V_{CC}$ or GND			0.2		0.2	mA	
$C_i$	$V_I = 3\text{ V or }0$				4		4	pF	
$C_{io}$	$V_O = 3\text{ V or }0$				11		11	pF	
$C_O$	$V_O = 3\text{ V or }0$				8		8	pF	

† All typical values are at  $V_{CC} = 3.3\text{ V}$ ,  $T_A = 25^\circ\text{C}$ .

‡ For conditions shown as MIN or MAX, use the appropriate value specified under recommended operating conditions.

§ Unused pins at  $V_{CC}$  or GND

¶ This is the increase in supply current for each input that is at the specified TTL voltage level rather than  $V_{CC}$  or GND.

NOTE 3: Product preview specifications are design goals only and are subject to change without notice.

**PRODUCT PREVIEW**



SN54LVT18640, SN54LVT182640, SN74LVT18640, SN74LVT182640

3.3-V ABT SCAN TEST DEVICES  
WITH 18-BIT INVERTING BUS TRANSCEIVERS

SCBS310A – MARCH 1994 – REVISED AUGUST 1994

timing requirements over recommended operating free-air temperature range (unless otherwise noted) (test mode) (see Note 3 and Figure 14)

			SN54LVT182640				SN74LVT182640				UNIT
			V <sub>CC</sub> = 3.3 V ± 0.3 V		V <sub>CC</sub> = 2.7 V		V <sub>CC</sub> = 3.3 V ± 0.3 V		V <sub>CC</sub> = 2.7 V		
			MIN	MAX	MIN	MAX	MIN	MAX	MIN	MAX	
f <sub>clock</sub>	Clock frequency	TCK					0	20		MHz	
t <sub>w</sub>	Pulse duration	TCK high or low					25			ns	
t <sub>su</sub>	Setup time	A, B, DIR, or $\overline{OE}$ before TCK↑					8			ns	
		TDI before TCK↑					8				
		TMS before TCK↑					6				
t <sub>h</sub>	Hold time	A, B, DIR, or $\overline{OE}$ after TCK↑					1			ns	
		TDI after TCK↑					1				
		TMS after TCK↑					1				
t <sub>d</sub>	Delay time	Power up to TCK↑					50			ns	
t <sub>r</sub>	Rise time	V <sub>CC</sub> power up					1			μs	

NOTE 3: Product preview specifications are design goals only and are subject to change without notice.

PRODUCT PREVIEW



**SN54LVT18640, SN54LVT182640, SN74LVT18640, SN74LVT182640**  
**3.3-V ABT SCAN TEST DEVICES**  
**WITH 18-BIT INVERTING BUS TRANSCEIVERS**

SCBS310A – MARCH 1994 – REVISED AUGUST 1994

**switching characteristics over recommended operating free-air temperature range (unless otherwise noted) (normal mode) (see Note 3 and Figure 14)**

PARAMETER	FROM (INPUT)	TO (OUTPUT)	SN54LVT182640				SN74LVT182640				UNIT
			V <sub>CC</sub> = 3.3 V ± 0.3 V		V <sub>CC</sub> = 2.7 V		V <sub>CC</sub> = 3.3 V ± 0.3 V		V <sub>CC</sub> = 2.7 V		
			MIN	MAX	MIN	MAX	MIN	MAX	MIN	MAX	
t <sub>PLH</sub>	A or B	B or A					1.5	8		ns	
t <sub>PHL</sub>							1.5	8			
t <sub>PZH</sub>	OE	B or A					3	10		ns	
t <sub>PZL</sub>							3	10			
t <sub>PHZ</sub>	OE	B or A					3	10.5		ns	
t <sub>PLZ</sub>							3	10.5			

**switching characteristics over recommended operating free-air temperature range (unless otherwise noted) (test mode) (see Note 3 and Figure 14)**

PARAMETER	FROM (INPUT)	TO (OUTPUT)	SN54LVT182640				SN74LVT182640				UNIT
			V <sub>CC</sub> = 3.3 V ± 0.3 V		V <sub>CC</sub> = 2.7 V		V <sub>CC</sub> = 3.3 V ± 0.3 V		V <sub>CC</sub> = 2.7 V		
			MIN	MAX	MIN	MAX	MIN	MAX	MIN	MAX	
f <sub>max</sub>	TCK↓							20		MHz	
t <sub>PLH</sub>	TCK↓	A or B					3	25		ns	
t <sub>PHL</sub>							3	25			
t <sub>PLH</sub>	TCK↓	TDO					2	12		ns	
t <sub>PHL</sub>							2	12			
t <sub>PZH</sub>	TCK↓	A or B					3	25		ns	
t <sub>PZL</sub>							3	25			
t <sub>PZH</sub>	TCK↓	TDO					2	12		ns	
t <sub>PZL</sub>							2	12			
t <sub>PHZ</sub>	TCK↓	A or B					3	25		ns	
t <sub>PLZ</sub>							3	25			
t <sub>PHZ</sub>	TCK↓	TDO					2	15		ns	
t <sub>PLZ</sub>							2	15			

NOTE 3: Product preview specifications are design goals only and are subject to change without notice.

**PRODUCT PREVIEW**



**SN54LVT18640, SN54LVT182640, SN74LVT18640, SN74LVT182640**  
**3.3-V ABT SCAN TEST DEVICES**  
**WITH 18-BIT INVERTING BUS TRANSCEIVERS**

SCBS310A – MARCH 1994 – REVISED AUGUST 1994

**PARAMETER MEASUREMENT INFORMATION**

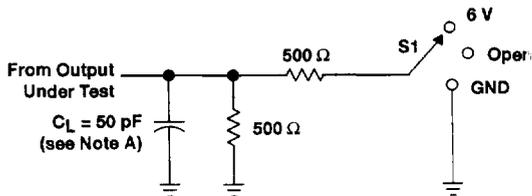

TEST	S1
$t_{PLH}/t_{PHL}$	Open
$t_{PLZ}/t_{PZL}$	6 V
$t_{PHZ}/t_{PZH}$	GND

LOAD CIRCUIT FOR OUTPUTS

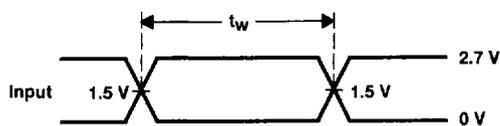

VOLTAGE WAVEFORMS  
PULSE DURATION

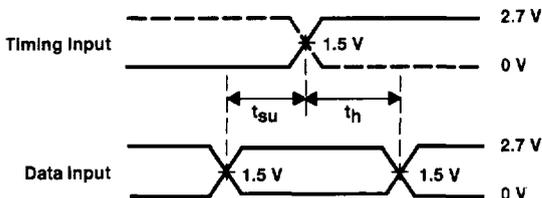

VOLTAGE WAVEFORMS  
SETUP AND HOLD TIMES

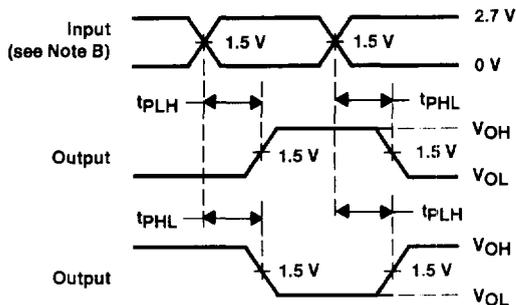

VOLTAGE WAVEFORMS  
PROPAGATION DELAY TIMES  
INVERTING AND NONINVERTING OUTPUTS

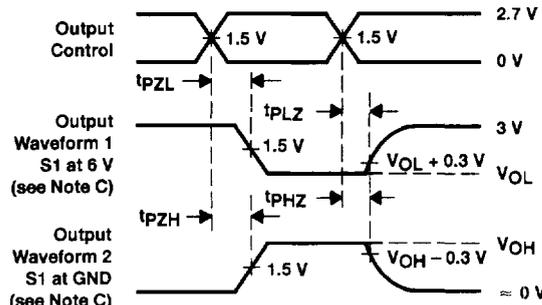

VOLTAGE WAVEFORMS  
ENABLE AND DISABLE TIMES  
LOW- AND HIGH-LEVEL ENABLING

- NOTES: A.  $C_L$  includes probe and jig capacitance.  
 B. All input pulses are supplied by generators having the following characteristics:  $f_c \leq 10$  MHz,  $Z_O = 50 \Omega$ ,  $t_r \leq 2.5$  ns,  $t_f \leq 2.5$  ns.  
 C. Waveform 1 is for an output with internal conditions such that the output is low except when disabled by the output control. Waveform 2 is for an output with internal conditions such that the output is high except when disabled by the output control.  
 D. The outputs are measured one at a time with one transition per measurement.

Figure 14. Load Circuit and Voltage Waveforms

PRODUCT PREVIEW

