

256K UVEPROM

UV Erasable Programmable
Read-Only Memory

AVAILABLE AS MILITARY SPECIFICATIONS

- -55C to 125C operation
- MILITARY Processing Methods
- Commercial Version Available

FEATURES

- Organized 32,768 x 8
- Single +5V ±10% power supply
- Pin-compatible with existing 256K ROM's and EPROM's
- All inputs/outputs fully TTL compatible
- Power-saving CMOS technology
- Very high-speed FLASHRITE Pulse Programming
- 3-state output buffers
- 400-mV DC assured noise immunity with standard TTL loads
- Latchup immunity of 250 mA on all input and output pins
- Low power dissipation (CMOS Input Levels)
 - Active - 165mW Worst Case
 - Standby - 1.7mW Worst Case (CMOS-input levels)
- * FUTURE High Speed Offerings: 55ns, 70ns, 90ns

OPTIONS

Timing

120ns access	-12
150ns access	-15
170ns access	-17
200ns access	-20
250ns access	-25
300ns access	-30
55ns access	-55
70ns access	-70
90ns access	-90

Package(s)

Ceramic DIP (600mils) J No. 110
Ceramic LCC (450 x 550 mils) ECA No. 208

Processing / Operating Temperature Ranges

Full Military (-55°C to +125°C) M
Industrial (-40°C to +85°C) I
Military Temp (-55°C to +125°C) XT

PIN ASSIGNMENT (Top View)

28-Pin DIP (J)
(600 MIL)

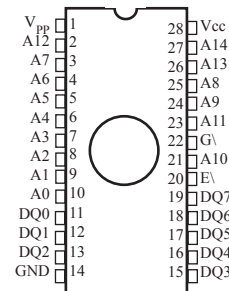

32-Pin LCC (ECA)
(450 x 550 mils)

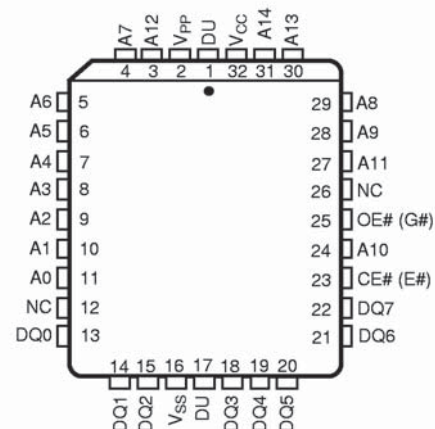

Pin Name	Function
A0 - A14	Address Inputs
DQ0-DQ7	Inputs (programming)/Outputs
E\	Chip Enable/Power Down
G\	Output Enable
GND	Ground
V _{CC}	5V Supply
V _{PP}	13V Programming Power Supply

For more products and information
please visit our web site at
www.micross.com

GENERAL DESCRIPTION

The AS27C256 series is a set of 262,144 bit, ultraviolet-light erasable, electrically programmable read-only memories. These devices are fabricated using power-saving CMOS technology for high speed and simple interface with MOS and bipolar circuits. All inputs (including program data inputs) can be driven by Series 54 TTL circuits without the use of external pullup resistors. Each output can drive one Series 54 TTL circuit without external resistors. The data outputs are 3-state for connecting multiple devices to a common bus. The AS27C256 is pin-compatible with 28-pin 256K ROMs and EPROMs. It is offered in a 600mil dual-in-line ceramic package (J suffix) and a 450 x 550 mil ceramic LCC (ECA suffix) rated for operation from -55°C to 125°C.

Because this EPROM operates from a single 5V supply

(in the read mode), it is ideal for use in microprocessor-based systems. One other supply (12.75V) is needed for programming. All programming signals are TTL level. This device is programmable by the AMD FLASHRITE Pulse programming algorithm. The FLASHRITE Pulse programming algorithm uses a V_{PP} of 12.75V and a V_{CC} of 6.25V for a nominal programming time of four seconds. For programming outside the system, existing EPROM programmers can be used. Locations can be programmed singly, in blocks, or at random.

FUNCTIONAL BLOCK DIAGRAM*

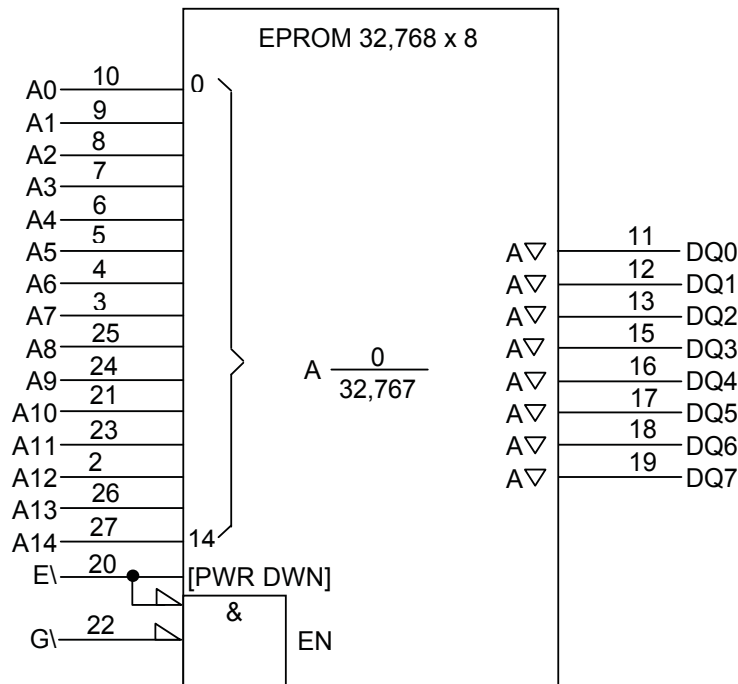

* This symbol is in accordance with ANSI/IEEE std 91-1984 and IEC Publication 617-12.

OPERATION

The seven modes of operation for the AS27C256 are listed in Table 1. The read mode requires a single 5V supply. All inputs are TTL level except for V_{pp} during programming (12.75V for FLASHRITE Pulse), and (12V) on A9 for signature mode.

TABLE 1. OPERATION MODES

FUNCTION (PINS)	MODE*							
	READ	OUTPUT DISABLE	STANDBY	PROGRAMMING	VERIFY	PROGRAM INHIBIT	SIGNATURE MODE	
E\	V_{IL}	V_{IL}	V_{IH}	V_{IL}	V_{IH}	V_{IH}	V_{IL}	
G\	V_{IL}	V_{IH}	X	V_{IH}	V_{IL}	X	V_{IL}	
V_{PP}	X ¹	X ¹	X ¹	V_{PP}	V_{PP}	V_{PP}	V_{CC}	
V_{CC}	V_{CC}	V_{CC}	$V_{CC} \pm .3V$	V_{CC}	V_{CC}	V_{CC}	V_{CC}	
A9	X	X	X	X	X	X	V_{ID}^2 V_{ID}^2	
A0	X	X	X	X	X	X	V_{IL} V_{IH}	
DQ0-DQ7	Data Out	High-Z	High-Z	Data In	Data Out	High-Z	CODE**	
							MFG	DEVICE
							01h	10h

¹For normal standby & read operation, V_{PP} is Don't Care X.

² $V_{ID} = 12V \pm .5V$

NOTES:

* X can be V_{IL} or V_{IH}

** Die is AMD. User can program on benchtop programmer by selecting AM27C256 from the device type selection menu.

READ/OUTPUT DISABLE

When the outputs of two or more AS27C256 are connected in parallel on the same bus, the output of any particular device in the circuit can be read with no interference from the competing outputs of the other devices. To read the output of the selected AS27C256, a low-level signal is applied to $E\backslash$ and $G\backslash$. All other devices in the circuit should have their outputs disabled by applying a high-level signal to one of these pins. Output data is accessed at pins DQ0 through DQ7.

LATCHUP IMMUNITY

Latchup immunity on the AS27C256 is a minimum of 250mA on all inputs and outputs. This feature provides latchup immunity beyond any potential transients at the printed circuit board level when the EPROM is interfaced to industry standard TTL or MOS logic devices. Input/output layout approach controls latchup without compromising performance or packing density.

POWER DOWN

Active I_{CC} supply current can be reduced from 25mA (AS27C256-12 through AS27C256-25) to 1mA (TTL-level inputs) or 300 μ A (CMOS-level inputs) by applying a high TTL/CMOS signal to the $E\backslash$ pin. In this mode all outputs are in the high-impedance state.

ERASURE

Before programming, the AS27C256 is erased by exposing the chip through the transparent lid to a high-intensity ultraviolet light (wavelength 2537 Å). EPROM erasure before programming is necessary to ensure that all bits are in the logic-high state. Logic-lows are programmed into the desired locations. A programmed logic-low can be erased only by ultraviolet light. The recommended minimum exposure dose (UV intensity x exposure time) is 15W•s/cm². A typical 12mW/cm², filterless UV lamp erases the device in 21 minutes. The lamp should be located about 2.5cm above the chip during erasure. After erasure, all bits are in the high state. It should be noted that normal ambient light contains the correct wavelength for erasure; therefore, when using the AS27C256, the window should be covered with an opaque label.

FLASHRITE PULSE PROGRAMMING

The AS27C256 EPROM is programmed by using the AMD FLASHRITE Pulse programming algorithm as illustrated by the flowchart in Figure 1. This algorithm programs the device in a nominal time of 4 seconds. Actual programming time varies as a function of the programmer used.

Data is presented in parallel (eight bits) on pins DQ0 to DQ7. Once addresses and data are stable, $E\backslash$ is pulsed.

The FLASHRITE Pulse programming algorithm uses initial pulses of 100 microseconds (μ s) followed by a byte-verification step to determine when the addressed byte has been successfully programmed. Up to 25 100 μ s pulses per byte are provided before a failure is recognized.

The programming mode is achieved when $V_{PP} = 12.75V$, $V_{CC} = 6.25V$, $G\backslash = V_{IH}$, and $E\backslash = V_{IL}$. More than one device can be programmed when the devices are connected in parallel. Locations can be programmed in any order. When the AMD FLASHRITE Pulse programming routine is completed, all bits are verified with $V_{CC} = V_{PP} = 5V$.

PROGRAM INHIBIT

Programming can be inhibited by maintaining a high-level input on $E\backslash$.

PROGRAM VERIFY

Programmed bits can be verified with $V_{PP} = 12.75V$ when $G\backslash = V_{IL}$, and $E\backslash = V_{IH}$.

SIGNATURE MODE

The signature mode provides access to a binary code identifying the manufacturer and device type. This mode is activated when A9 is forced to 12V \pm 0.5V. Two identifier bytes are accessed by A0 (terminal 10); i.e., $A0 = V_{IL}$ accesses the manufacturer code, which is output on DQ0-DQ7; $A0 = V_{IH}$ accesses the device code, which is also output on DQ0-DQ7. All other addresses must be held at VIL. Each byte contains odd parity on bit DQ7. The manufacturer code for these devices is 01h and the device code is 10h.

FIGURE 1. FLASHRITE PULSE PROGRAMMING FLOWCHART

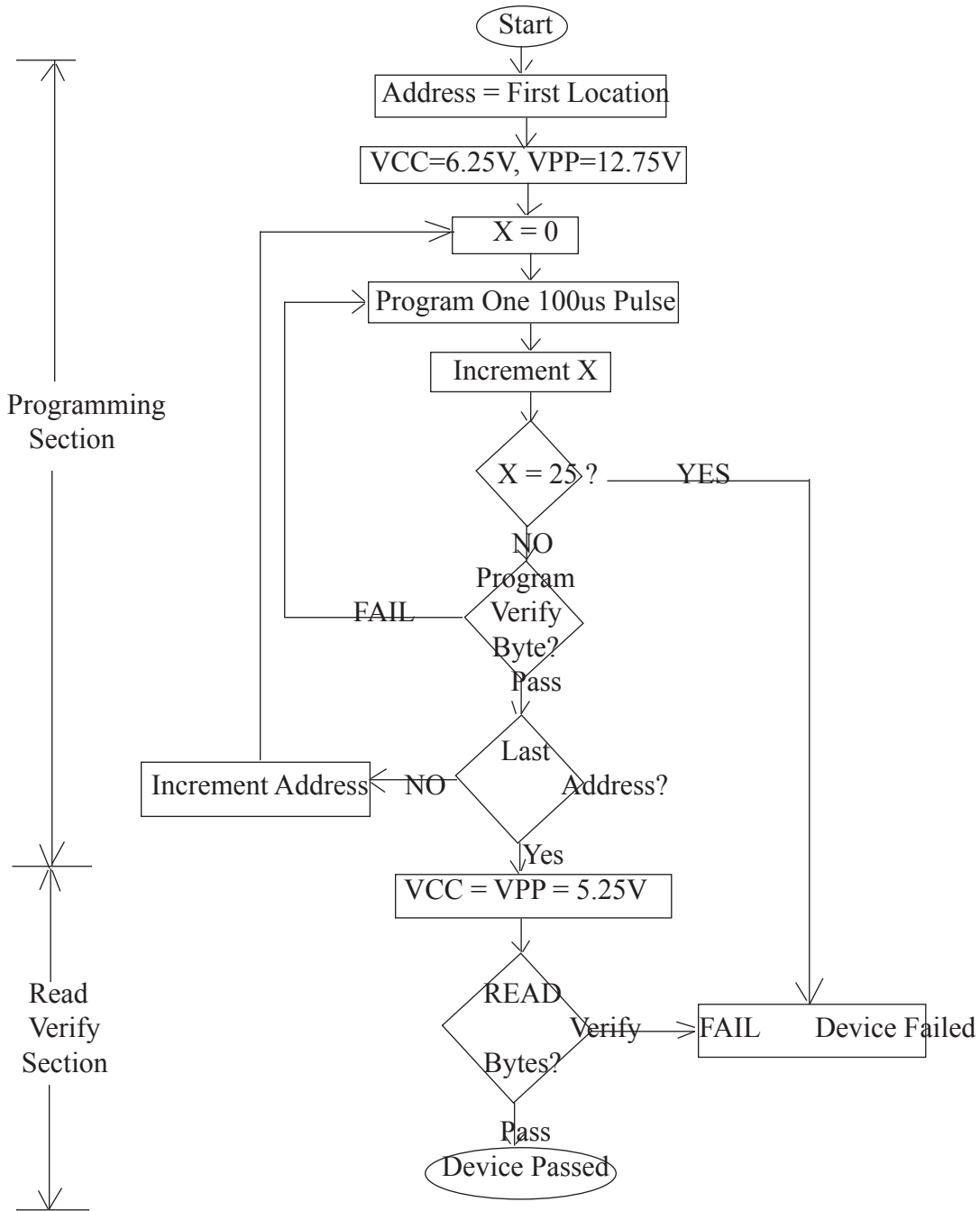

ABSOLUTE MAXIMUM RATINGS*

Supply Voltage Range, V_{CC}^{**}	-0.6V to +7.0V
Supply Voltage Range, V_{PP}^{**}	-0.6V to +13.5V
Input Voltage Range, All inputs except A9**	-0.6V to +6.0V
A9	-0.6V to +13.5V
Output Voltage Range**	-0.6V to $V_{CC} + 0.6V$
Minimum Operating Free-air Temperature, T_A	-55°C
Maximum Operating Case Temperature, T_C	125°C
Storage Temperature Range, T_{stg}	-65°C to 150°C

*Stresses greater than those listed under “Absolute Maximum Ratings” may cause permanent damage to the device. This is a stress rating only and functional operation of the device at these or any other conditions above those indicated in the operation section of this specification is not implied. Exposure to absolute maximum rating conditions for extended periods may affect reliability.

** All voltage values are with respect to GND.

RECOMMENDED OPERATING CONDITIONS

		MIN	TYP	MAX	
V_{CC}	Supply Voltage	Read Mode ¹	4.5	5	5.5
		FLASHRITE Pulse programming algorithm	6	6.25	6.5
V_{PP}	Supply Voltage	Read Mode ²			$V_{CC}-0.6$
		FLASHRITE Pulse programming algorithm	12.5	12.75	13
V_{IH}	High-level input voltage	TTL inputs	2.2		$V_{CC}+0.6$
		CMOS inputs	$V_{CC}-0.2$		$V_{CC}+0.6$
V_{IL}	Low-level input voltage	TTL inputs	-0.5		0.8
		CMOS inputs	-0.5		0.2
V_{ID}	Voltage level on A9 for signature mode		11.5	12	12.5
T_A	Operating free-air temperature		-55		
T_C	Operating case temperature				+125

NOTES:

1. V_{CC} must be applied before or at the same time as V_{PP} and removed after or at the same time as V_{PP} . The device must not be inserted into or removed from the board when V_{PP} or V_{CC} is applied.

2. V_{PP} can be connected to V_{CC} directly (except in the program mode). V_{CC} supply current in this case would be $I_{CC2} + I_{PP1}$.

ELECTRICAL CHARACTERISTICS OVER RECOMMENDED RANGES OF SUPPLY VOLTAGE AND OPERATING FREE-AIR TEMPERATURE

PARAMETER		TEST CONDITIONS	MIN	TYP ¹	MAX	UNIT
V_{OH}	High-level output voltage	$I_{OH} = -400\mu A$	2.4			V
V_{OL}	Low-level output voltage	$I_{OL} = 2.1mA$			0.4	V
I_I	Input current (leakage)	$V_I = 0V$ to 5.5V			± 1	μA
I_O	Output current (leakage)	$V_O = 0V$ to V_{CC}			± 5	μA
I_{PP1}	V_{PP} supply current	$V_{PP} = V_{CC} = 5.5V$			100	μA
I_{PP2}	V_{PP} supply current (during program pulse) ²	$V_{PP} = 13V$		30	50	mA
I_{CC1}	V_{CC} supply current (standby)	TTL-Input Level	$V_{CC} = 5.5V, E_I = V_{IH}$		1	mA
		CMOS-Input Level	$V_{CC} = 5.5V, E_I = V_{CC}$		300	μA
I_{CC2}	V_{CC} supply current (active)	'27C256-12 '27C256-15 '27C256-17 '27C256-20,-25 $E_I = V_{IL}, V_{CC} = 5.5V$ $t_{cycle} = \text{minimum, outputs open}$		15	25	mA

NOTES:

1. Typical values are at $T_A = 25^\circ C$ and nominal voltages.

2. This parameter has been characterized at 25°C and is not tested.

CAPACITANCE OVER RECOMMENDED RANGES OF SUPPLY VOLTAGE AND OPERATING FREE-AIR TEMPERATURE, $f = 1\text{MHz}^*$

PARAMETER		TEST CONDITIONS	TYP**	MAX	UNIT
C_i	Input capacitance	$V_I = 0\text{V}$	6	10	pF
C_o	Output capacitance	$V_O = 0\text{V}$	10	14	pF

* Capacitance measurements are made on a sample basis only.

** Typical values are at $T_A = 25^\circ\text{C}$ and nominal voltages.

SWITCHING CHARACTERISTICS OVER RECOMMENDED RANGES OF SUPPLY VOLTAGE AND OPERATING FREE-AIR TEMPERATURE^{1,2}

PARAMETER		TEST CONDITIONS ^{1, 2}	-12		-15		UNIT
			MIN	MAX	MIN	MAX	
$t_{a(A)}$	Access time from address	see Figure 2		120		150	ns
$t_{a(E)}$	Access time from E\			120		150	ns
$t_{en(G)R}$	Output enable time from G\			40		50	ns
t_{dis}	Disable time of output from G\ or E\, whichever occurs first ³		0	30	0	30	ns
$t_{v(A)}$	Output data valid time after change of address, E\, or G\, whichever occurs first ³		0		0		ns

PARAMETER		TEST CONDITIONS ^{1, 2}	-17		-20		-25		UNIT
			MIN	MAX	MIN	MAX	MIN	MAX	
$t_{a(A)}$	Access time from address	see Figure 2		170		200		250	ns
$t_{a(E)}$	Access time from E\			170		200		250	ns
$t_{en(G)R}$	Output enable time from G\			50		60		60	ns
t_{dis}	Disable time of output from G\ or E\, whichever occurs first ³		0	40	0	50	0	60	ns
$t_{v(A)}$	Output data valid time after change of address, E\, or G\, whichever occurs first ³		0		0		0		ns

NOTES:

1. Timing measurements are made at 2V for logic high and 0.8V for logic low (see figure 2).

2. Common test conditions apply for t_{dis} except during programming.

3. Value calculated from 0.5V delta to measured output level. This parameter is only sampled and not 100% tested.

**SWITCHING CHARACTERISTICS FOR PROGRAMMING: $V_{CC} = 6.5\text{V}$ and $V_{PP} = 12.75\text{V}$
(AMD FLASHRITE ALGO), $T_A = 25^\circ\text{C}$**

PARAMETER		MIN	MAX	UNIT
$t_{dis(G)}$	Output disable time from G\	0	130	ns
$t_{en(G)W}$	Output enable time from G\		150	ns

RECOMMENDED TIMING REQUIREMENTS FOR PROGRAMMING: $V_{CC} = 6.5$ and $V_{PP} = 12.75V$ (AMD FLASHRITE ALGO), $T_A = 25^\circ C$ (See Figure 2)

		MIN	TYP	MAX	UNIT
$t_{h(A)}$	Hold Time, Address	0			μs
$t_{h(D)}$	Hold Time, Data	2			μs
$t_{w(E)PR}$	Pulse Duration, Initial Program	95	100	105	μs
$t_{su(A)}$	Setup Time, Address	2			μs
$t_{su(G)}$	Setup Time, G\	2			μs
$t_{su(E)}$	Setup Time, E\	2			μs
$t_{su(D)}$	Setup Time, Data	2			μs
$t_{su(VPP)}$	Setup Time, V_{PP}	2			μs
$t_{su(VCC)}$	Setup Time, V_{CC}	2			μs

PARAMETER MEASUREMENT INFORMATION

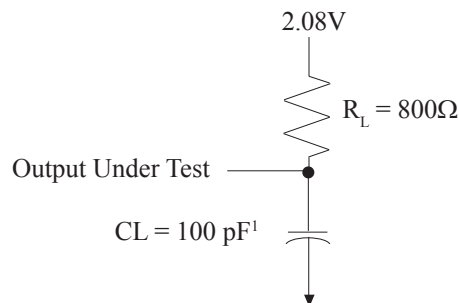

NOTES:

1. C_L includes probe and fixture capacitance.

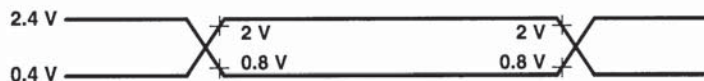

The AC testing inputs are driven at 2.4V for logic high and 0.4V for logic low. Timing measurements are made at 2V for logic high and 0.8V for logic low for both inputs and outputs.

FIGURE 2. LOAD CIRCUIT AND VOLTAGE WAVEFORMS

FIGURE 3. READ-CYCLE TIMING

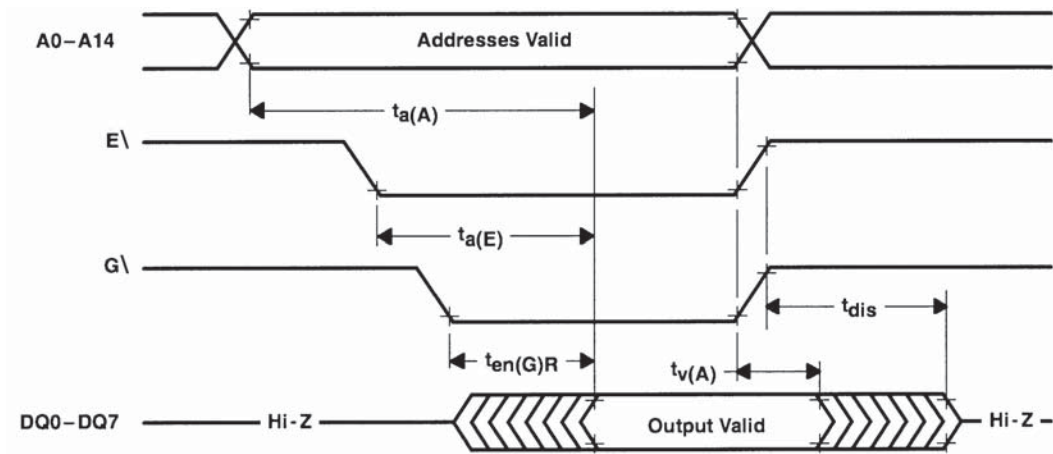
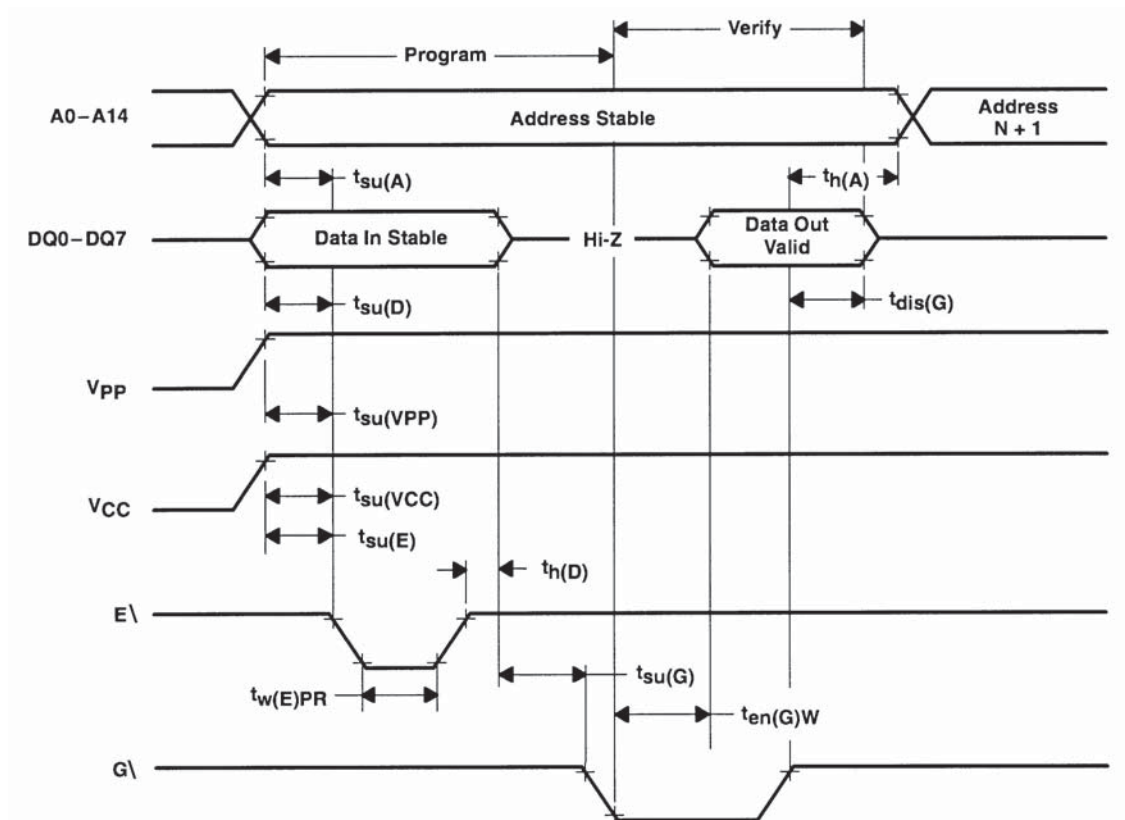
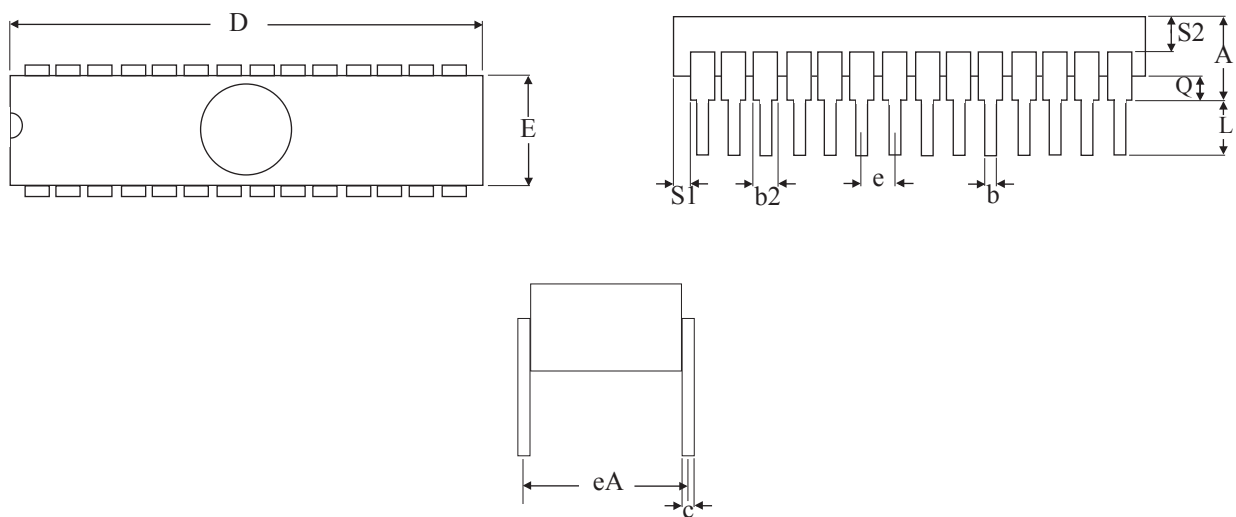

FIGURE 4. PROGRAM-CYCLE TIMING (FLASHWRITE PULSE PROGRAMMING)



MECHANICAL DEFINITION*

Micross Case #110 (Package Designator J)



SYMBOL	SMD SPECIFICATIONS	
	MIN	MAX
A	--	0.232
b	0.014	0.026
b2	0.045	0.065
c	0.008	0.018
D	--	1.490
E	0.500	0.610
eA	0.600 BSC	
e	0.100 BSC	
L	0.125	0.200
Q	0.015	0.060
S1	0.005	--
S2	0.005	--

*All measurements are in inches.

MECHANICAL DEFINITIONS*

Micross Case #208 (Package Designator ECA)

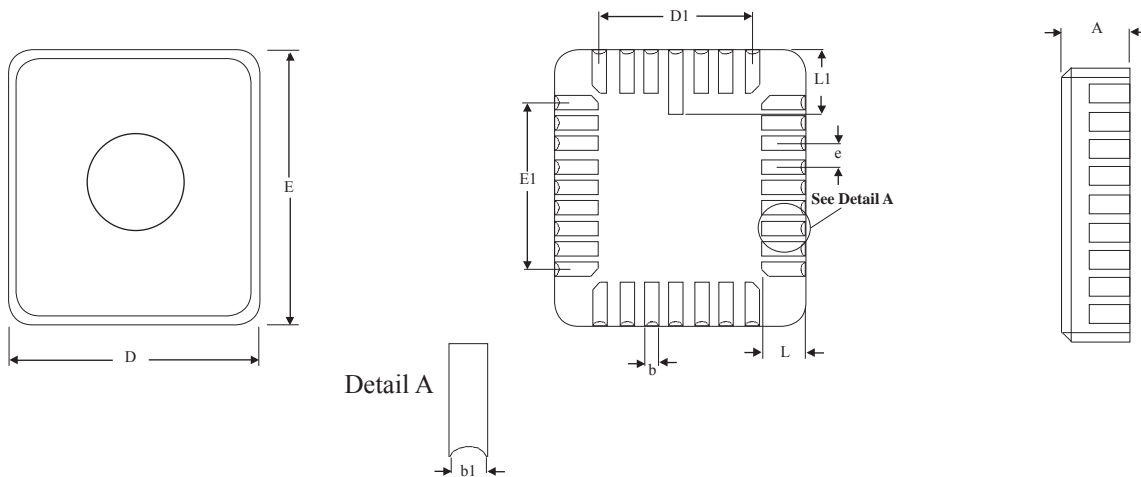

SYMBOL	SMD SPECIFICATIONS	
	MIN	MAX
A	0.060	0.120
b	0.022	0.028
b1	0.006	0.022
D	0.442	0.458
D1	0.300 BSC	
E	0.540	0.560
E1	0.400 BSC	
e	0.050 BSC	
L	0.045	0.055
L1	0.075	0.095

*All measurements are in inches.

ORDERING INFORMATION

EXAMPLE: AS27C256-30JM/MIL

Device Number	Speed	Package Type	Operating Temp.
AS27C256	-55	J	*
AS27C256	-70	J	*
AS27C256	-90	J	*
AS27C256	-12	J	*
AS27C256	-15	J	*
AS27C256	-17	J	*
AS27C256	-20	J	*
AS27C256	-25	J	*
AS27C256	-30	J	*

EXAMPLE: AS27C256-15ECAM

Device Number	Speed	Package Type	Operating Temp.
AS27C256	-55	ECA	*
AS27C256	-70	ECA	*
AS27C256	-90	ECA	*
AS27C256	-12	ECA	*
AS27C256	-15	ECA	*
AS27C256	-17	ECA	*
AS27C256	-20	ECA	*
AS27C256	-25	ECA	*
AS27C256	-30	ECA	*

***PROCESS / OPERATING TEMPERATURE**

M = Full Military Processing Per -55°C to +125°C
MIL-PRF-3835, Class Q
I = Industrial Temperature Range -40°C to +85°C
XT = Military Temperature Range -55°C to +125°C

SM

SMD ORDERING INFORMATION

SMD	ASI PN	SPEED	PACKAGE
5962-8606301XA	AS27C256 -20JM	200ns	600mil, 28LD. DIP
5962-8606311XA	AS27C256 -20JM	200ns	600mil, 28LD. DIP
5962-8606302XA	AS27C256 -25JM	250ns	600mil, 28LD. DIP
5962-8606312XA	AS27C256 -25JM	250ns	600mil, 28LD. DIP
5962-8606303XA	AS27C256 -30JM	300ns	600mil, 28LD. DIP
5962-8606313XA	AS27C256 -30JM	300ns	600mil, 28LD. DIP
5962-8606304XA	AS27C256 -17JM	170ns	600mil, 28LD. DIP
5962-8606314XA	AS27C256 -17JM	170ns	600mil, 28LD. DIP
5962-8606305XA	AS27C256 -15JM	150ns	600mil, 28LD. DIP
5962-8606315XA	AS27C256 -15JM	150ns	600mil, 28LD. DIP
5962-8606306XA	AS27C256 -12JM	120ns	600mil, 28LD. DIP
5962-8606316XA	AS27C256 -12JM	120ns	600mil, 28LD. DIP
5962-8606307XA	AS27C256 -90JM	90ns	600mil, 28LD. DIP
5962-8606317XA	AS27C256 -90JM	90ns	600mil, 28LD. DIP
5962-8606308XA	AS27C256 -70JM	70ns	600mil, 28LD. DIP
5962-8606318XA	AS27C256 -70JM	70ns	600mil, 28LD. DIP
5962-8606309XA	AS27C256 -55JM	55ns	600mil, 28LD. DIP
5962-8606319XA	AS27C256 -55JM	55ns	600mil, 28LD. DIP

SMD	ASI PN	SPEED	PACKAGE
5962-8606301YA	AS27C256 -20ECA	200ns	32-LD. 0.450 x 0.550, LCC
5962-8606311YA	AS27C256 -20ECA	200ns	32-LD. 0.450 x 0.550, LCC
5962-8606302YA	AS27C256 -25ECA	250ns	32-LD. 0.450 x 0.550, LCC
5962-8606312YA	AS27C256 -25ECA	250ns	32-LD. 0.450 x 0.550, LCC
5962-8606303YA	AS27C256 -30ECA	300ns	32-LD. 0.450 x 0.550, LCC
5962-8606313YA	AS27C256 -30ECA	300ns	32-LD. 0.450 x 0.550, LCC
5962-8606304YA	AS27C256 -17ECA	170ns	32-LD. 0.450 x 0.550, LCC
5962-8606314YA	AS27C256 -17ECA	170ns	32-LD. 0.450 x 0.550, LCC
5962-8606305YA	AS27C256 -15ECA	150ns	32-LD. 0.450 x 0.550, LCC
5962-8606315YA	AS27C256 -15ECA	150ns	32-LD. 0.450 x 0.550, LCC
5962-8606306YA	AS27C256 -12ECA	120ns	32-LD. 0.450 x 0.550, LCC
5962-8606316YA	AS27C256 -12ECA	120ns	32-LD. 0.450 x 0.550, LCC
5962-8606307YA	AS27C256 -90ECA	90ns	32-LD. 0.450 x 0.550, LCC
5962-8606317YA	AS27C256 -90ECA	90ns	32-LD. 0.450 x 0.550, LCC
5962-8606308YA	AS27C256 -70ECA	70ns	32-LD. 0.450 x 0.550, LCC
5962-8606318YA	AS27C256 -70ECA	70ns	32-LD. 0.450 x 0.550, LCC
5962-8606309YA	AS27C256 -55ECA	55ns	32-LD. 0.450 x 0.550, LCC
5962-8606319YA	AS27C256 -55ECA	55ns	32-LD. 0.450 x 0.550, LCC