

High-Voltage EL Lamp Driver – 220 V_{PP} Drive

The IMP528 is an Electroluminescent (EL) lamp driver with the four EL lamp driving functions on-chip. These are the switch-mode power supply, its high-frequency oscillator, the high-voltage H-bridge lamp driver and its low-frequency oscillator. The IMP528 drives EL lamps of up to 50nF capacitance to high brightness; EL lamps with capacitances greater than 50nF can be driven, but will be lower in light output. The typical regulated output voltage that is applied to the EL lamp is 220V peak-to-peak. The circuit requires few external components; a single inductor, single diode, two capacitors and three resistors. Two of these resistors set the frequency for two internal oscillators.

Unlike other EL lamp drivers, the IMP528 does not require an external protection resistor in series with the EL lamp.

The IMP528 operates over a 2.0V to 6.5V supply voltage range. A regulated, low-power source can supply the low quiescent current of the IMP528. The inductor may be driven from an independent, unregulated supply voltage in dual supply applications.

An internal circuit shuts down the switching regulator when the lamp drive voltage reaches 220V peak-to-peak. This conserves power and extends battery life.

The IMP528 is available in MicroSO and SO-8 packages and in die or wafer form.

Key Features

- ◆ 220V peak-to-peak typical AC output voltage
- ◆ Low Power: 420µA typical V_{DD} current
- ◆ Wide operating voltage range - from 2.0V to 6.5V
- ◆ Large output load capability - drives lamps with more than 50nF capacitance
- ◆ Eliminates external protection resistor in series with EL lamp
- ◆ Adjustable output lamp frequency for control of lamp color, lamp life, and power consumption
- ◆ Adjustable converter frequency to minimize power consumption
- ◆ High-Voltage CMOS Process
- ◆ MicroSO package option

Applications

- ◆ GPS units/Pagers/Cellular phones
- ◆ PDAs/Handheld computers
- ◆ Safety illumination
- ◆ Portable instrumentation
- ◆ Battery-operated displays
- ◆ LCD modules
- ◆ Toys

Block Diagram

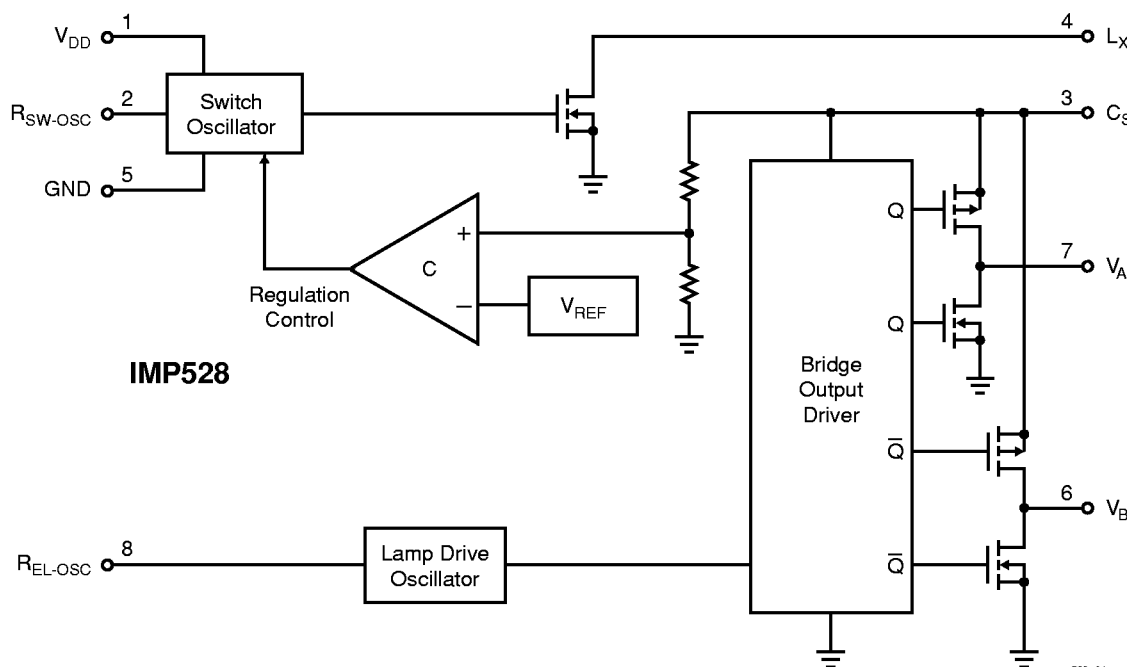

528_01 eps

Pin Configuration

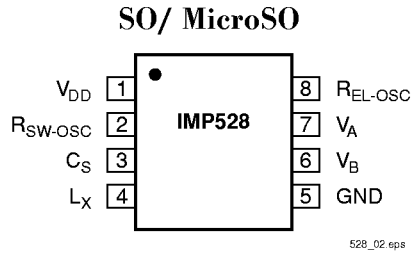

Pin Compatible With IMP803 and IMP560

Ordering Information

Part Number	Input Voltage	Regulated Output Voltage	Temperature Range	Pins-Package
IMP528ESA	2.0V to 6.5V	Yes	-40°C to +85°C	8-SO
IMP528EMA	2.0V to 6.5V	Yes	-40°C to +85°C	8-MicroSO
IMP528/D	2.0V to 6.5V	Yes	25°C	Dice
IMP528/D1	2.0V to 6.5V	Yes	25°C	Dice

Add /T to ordering part number for Tape and Reel.

Absolute Maximum Ratings

V_{DD}	-0.5V to +7.0V
$V_{RSW-OSC}$ and $V_{REL-OSC}$	-0.5V to $V_{DD}+0.3V$
V_{CS} , L_X	-0.5V to +120V
Operating Temperature Range	-40°C to +85°C
Storage Temperature Range	-65°C to +150°C
Power Dissipation (SO)	400mW
Power Dissipation (MicroSO)	300mW
V_A , V_B	-0.5V to V_{CS} (pin 3)

Note: All voltages are referenced to GND.

These are stress ratings only and functional operation is not implied. Exposure to absolute maximum ratings for prolonged time periods may affect device reliability.

Electrical Characteristics

Unless otherwise noted, $V_{DD} = 3.0V$, $R_{SW} = 910k\Omega$, $R_{EL} = 2.7M\Omega$, and $T_A = 25^\circ C$.

Parameter	Symbol	Conditions	Min	Typ	Max	Units
ON-resistance of MOS Switch	$R_{DS(ON)}$	$I = 100mA$		3.0	8	Ω
Output Voltage Regulation	V_{CS}	$V_{DD} = 2.0$ to $6.5V$		110		V
Output Voltage Peak-to-peak (in regulation)	$V_A - V_B$	$V_{DD} = 2.0$ to $6.5V$		220		V
Input Current at V_{DD} Pin	I_{DD}	$V_{DD} = 3.0V$, See Figure 1		420	700	μA
Input Current at V_{DD} Pin	I_{DD}	$V_{DD} = 5.0V$		500	750	μA
Quiescent V_{DD} Supply Current, Disabled	I_{DDQ}	$V_{RSW-OSC} < 100mV$		20	200	nA
Input Current: I_{DD} Plus Inductor Current	I_{IN}	$V_{DD} = 3.0V$, See Figure 1		21	31	mA
Output Voltage at V_{CS}	V_{CS}	$V_{DD} = 3.0V$, See Figure 1		110		V
$V_{A,B}$ Output Drive Frequency	f_{EL}	$V_{DD} = 3.0V$, See Figure 1		250		Hz
Switching Frequency	f_{SW}	$V_{DD} = 3.0V$, See Figure 1		61		kHz
Switching Duty Cycle	D_{SW}	$V_{DD} = 3.0V$, See Figure 1		88		%

Pin Descriptions

Pin Number	Name	Function
1	V_{DD}	Positive voltage supply for the IMP528. Inductor L may be connected here or to a separate unregulated supply.
2	R_{SW-OSC}	Switch-mode resistor pin. Switching frequency is determined by an external resistor, R_{SW} .
3	C_S	Boost converter storage capacitor. The voltage across the EL lamp is equal to twice the voltage at C_S .
4	L_X	Connection to flyback inductance, L.
5	GND	Ground pin.
6	V_B	EL lamp drive. The lamp is connected in a high-voltage bridge circuit with V_B providing the complementary connection to V_A . The peak-to-peak AC voltage across the EL lamp is thus two times V_{CS} .
7	V_A	EL lamp drive. (See above)
8	R_{EL-OSC}	The EL lamp oscillator frequency setting pin. The oscillator frequency is controlled by external resistor R_{EL} .

Detailed Descriptions

External Component	Description and Selection Guide
Diode	Catch diode. A fast reverse recovery diode, with $BV > 150V$, such as an FDLL400 (150V).
Capacitor C_S	This is the high voltage capacitor that stores the inductive energy transferred through the catch diode. A capacitor with $WV > 120V$ between 10nF and 100nF is recommended.
Resistor R_{EL}	The EL lamp oscillator frequency setting resistor. This resistor, connected between the R_{EL-OSC} pin and V_{DD} , provides an oscillator frequency inversely proportional to R_{EL} ; as R_{EL} increases, the EL lamp frequency decreases along with the current drawn by the lamp. Lamp color is also determined by this frequency. A 2.7M Ω resistor between the R_{EL-OSC} pin and the V_{DD} supply results in a lamp frequency around 250Hz.
Resistor R_{SW}	Switching Oscillator frequency setting resistor. The switching oscillator resistor is connected between the R_{SW-OSC} pin and the V_{DD} supply. The switching frequency is inversely proportional to the resistor value, dropping as the resistance increases.
Inductor L	<p>The inductor provides the voltage boost needed by means of inductive "flyback". The internal MOSFET switch alternately opens and closes the ground connection for the inductor at the L_X pin. When this internal switch opens, the inductor potential will forward-bias the catch diode and the current will pass through the storage capacitor C_S, charging it to a high voltage.</p> <p>Smaller inductors are preferred to prevent saturation. As the value of the inductor increases (and the series DC resistance of the inductor decreases), the switching frequency set by R_{SW} should be increased to prevent saturation. In general, smaller value inductors that can handle more current are more desirable when larger area EL lamps must be driven.</p>

Application Information

Test and Application Circuit, 3.0V

Figure 1 shows the IMP528 configured to drive an EL lamp with a 3.0V input.

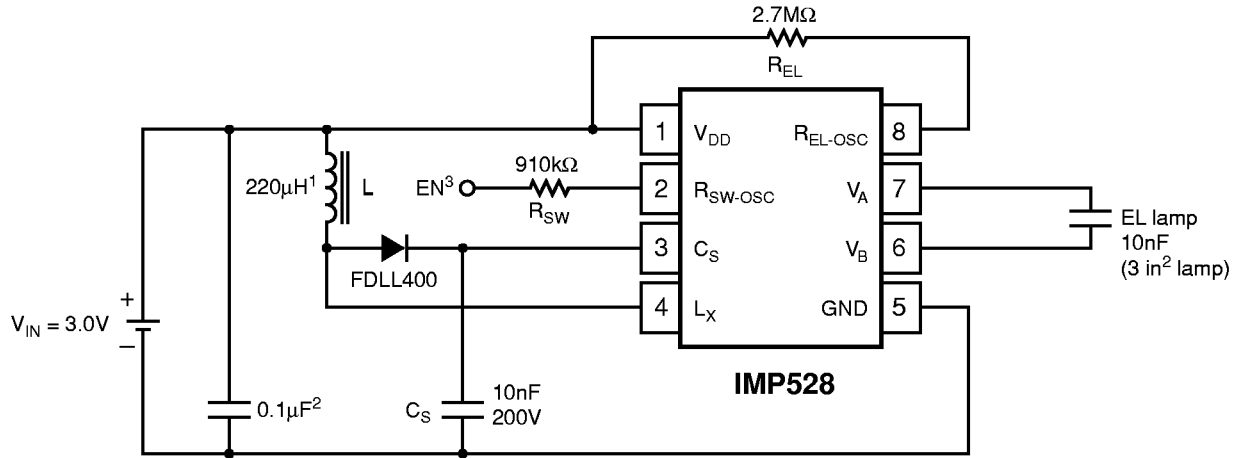

Note:

1. Murata part # LQH4N221K04 (DC resistance <math><5\Omega</math>)
2. Larger values may be required depending upon supply impedance.
3. EN is connected to V_{DD} to enable and to GND to disable.

528_03.eps

Figure 1. 3.0V Application

Dual Supply Operation with 1.5V Battery

The IMP528 can also be operate from a single battery cell when a regulated voltage higher than 2.0V is also available. This dual supply configuration, shown in Figure 2, uses the regulated

voltage to operate the IMP528 while the energy for the high-voltage boost circuit comes from the battery.

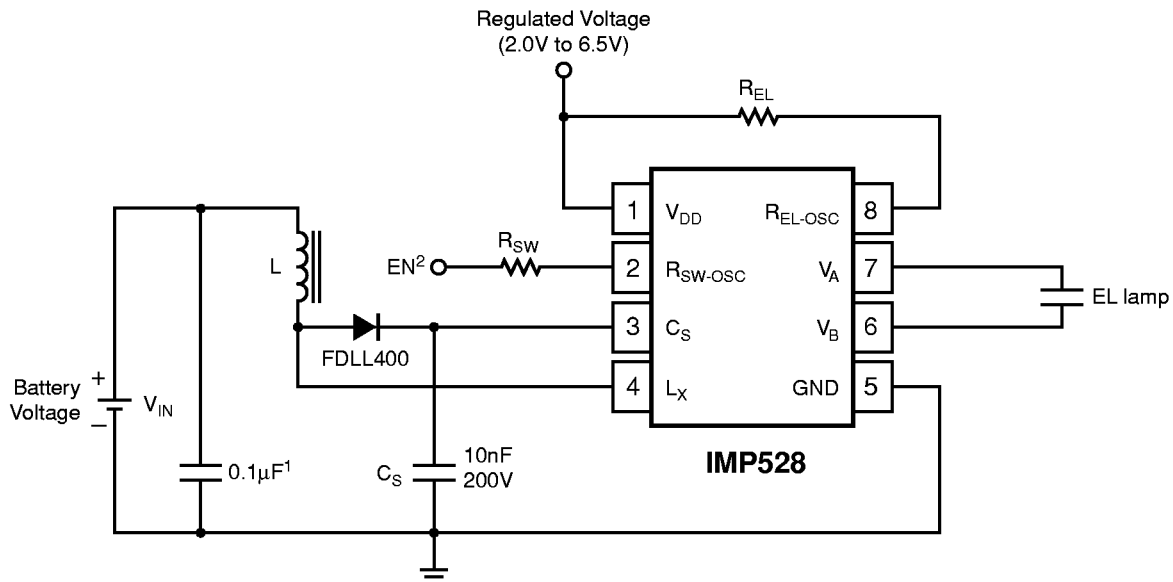

1. Larger values may be required depending upon supply impedance.
2. EN is connected to V_{DD} to enable and to GND to disable.

528_04.eps

Figure 2. Dual Supply Operation

High-Voltages Present

Switch Resistance

The IMP528 inductor switch resistance is typically below 3.5Ω, as shown in *Figure 3*.

The IMP528 generates high voltages and caution should be exercised.

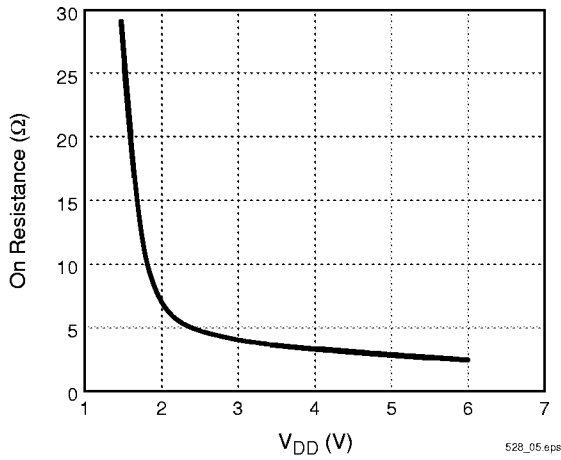
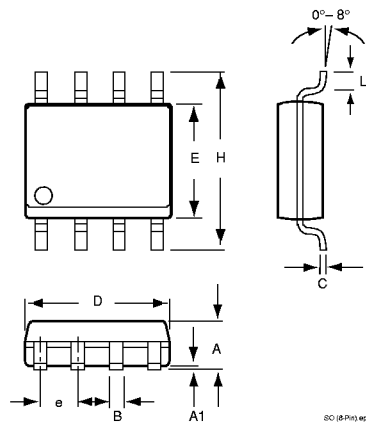

Figure 3. Boost Switch ON-Resistance

Package Dimensions

SO (8-Pin)



MicroSO (8-Pin)

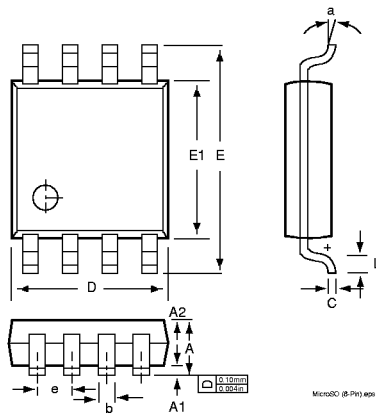

	Inches		Millimeters	
	Min	Max	Min	Max
SO (8-Pin)*				
A	0.053	0.069	1.35	1.75
A1	0.004	0.010	0.10	0.25
B	0.013	0.020	0.33	0.51
C	0.007	0.010	0.19	0.25
e	0.050		1.27	
E	0.150	0.157	3.80	4.00
H	0.228	0.244	5.80	6.20
L	0.016	0.050	0.40	1.27
D	0.189	0.197	4.80	2.00
MicroSO (8-Pin)**				
A	—	0.0433	—	1.10
A1	0.0020	0.0059	0.050	0.15
A2	0.0295	0.0374	0.75	0.95
b	0.0098	0.0157	0.25	0.40
C	0.0051	0.0091	0.13	0.23
D	0.1142	0.1220	2.90	3.10
e	0.0256 BSC		0.65 BSC	
E	0.193 BSC		4.90 BSC	
E1	0.1142	0.1220	2.90	3.10
L	0.0157	0.0276	0.40	0.70
a	0°	6°	0°	6°

* JEDEC Drawing MS-012AA

** JEDEC Drawing MO-187AA

528_101 at3