

Integrated Low Profile Transceiver Module for Telecom Applications

9.6 kbit/s to 1.152 Mbit/s Data Transmission Rate



Description

The miniaturized TFDU5106 in the well-known Baby Face package is an ideal transceiver for applications in telecommunications like mobile phones, pagers, and PDAs of all kinds. The device designed for optimum performance and minimum package size.

The device covers the IrDA[®] physical layer version 1.3 specification (30 cm with low intensity setting), the original SIR specification and the original 1.152 Mbit/s IrDA[®] mode.

The new features

Two different current levels can be used: A **current control** is built-in for the low power mode.

The device covers the supply voltage **from 5.5 V down to 2.4 V** and with its **low power consumption** it is optimum suited for battery powered applications. Eye safety protection is integrated.

Features

- Package:
 - **TFDU5106 Universal (Baby Face)**
 - SMD Side and Top View Solderability
- Compatible to IrDA Telecom Standard with Lowest Current Consumption
- Wide Supply Voltage Range (2.4 V to 5.5 V)
- Operational down to 2.0 V
- Internal Programmable Current Control
- Tri – State – Receiver Output
- Lowest Power Consumption
<200 μ A, Receive Mode, <1 μ A Shutdown
only typical 5 mA Average Current Consumption
in Low Power SIR and 1.152 Mbit/s Transmit Mode
- Fewest External Components
- High EMI Immunity
- Eye Safety Protection Integrated
- Pin Assignment Backward Compatible to Legacy Baby Face Package

Applications

- Mobile Phones, Pagers, Hand-held Battery Operated Equipment
- Computers (WinCE, PalmPC, PDAs)
- Digital Still and Video Cameras
- Extended IR Adapters
- Medical and Industrial Data Collection

Package

TFDU5106
Baby Face (Universal)



Ordering Information

Part Number	Qty / Reel	Description
TFDU5106-TR3	1000 pcs	Oriented in carrier tape for side view surface mounting
TFDU5106-TT3	1000 pcs	Oriented in carrier tape for top view surface mounting

Functional Block Diagram

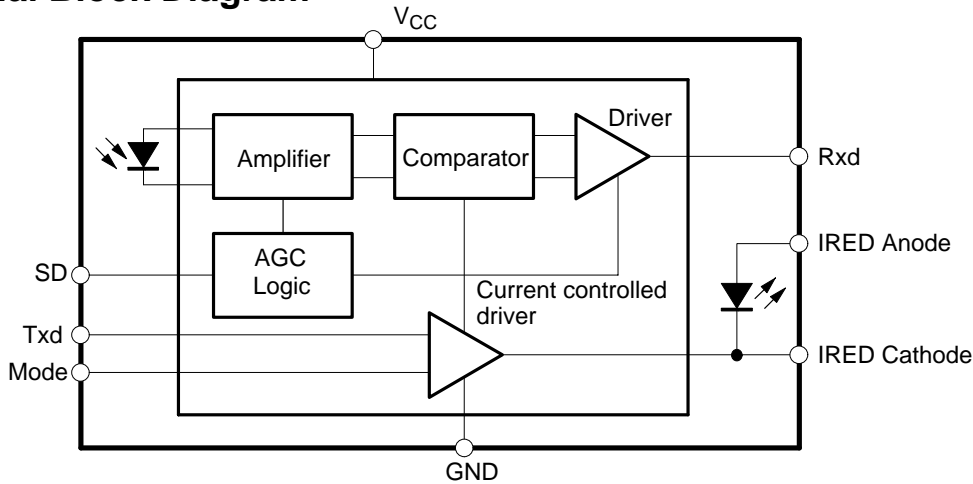

Figure 1. Functional Block Diagram

Pin Description

Pin Number	Function	Description	I/O	Active
1	IRED Anode	IRED Anode to be externally connected to V_{CC} through a current control resistor. This pin is allowed to be supplied from an uncontrolled power supply separated from the controlled V_{CC} supply		
2	IRED Cathode	IRED Cathode, internally connected to driver transistor		
3	Txd	Transmit Data Input	I	HIGH
4	Rxd	Received Data Output, push-pull CMOS driver output capable of driving a standard CMOS or TTL load. No external pull-up or pull-down resistor is required. Pin is floating with a weak pull up when device is in shutdown mode. Rxd output is quiet during transmission.	O	LOW
5	SD	Shutdown, will switch the device into shutdown after a delay of 1 ms	I	HIGH
6	V_{CC}	Supply Voltage		
7	Mode	HIGH: Output current/ intensity defined by external current limit resistor. LOW: Output current controlled for "low power mode"	I	
8	GND	Ground		

Baby Face (Universal)

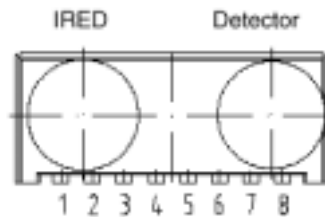

Figure 2. Pinning



Absolute Maximum Ratings

Reference Point Ground, Pin 8, unless otherwise noted

Parameters	Test Conditions	Symbol	Min.	Typ.	Max.	Unit
Supply Voltage Range	$0\text{ V} < V_{dd2} < 6\text{ V}$	V_{dd1}	-0.5		6	V
	$0\text{ V} < V_{dd1} < 6\text{ V}$	V_{dd2}	-0.5		6	V
Input Current	All Pins (Pin 1 excluded)				10	mA
Output Sink Current, Rxd	Pin 4				25	mA
Rep. Pulsed IRED Current	Pin 1, $t_{on} < 20\%$, $< 20\text{ }\mu\text{s}$	$I_{IRED(RP)}$			500	mA
Average IRED Current		$I_{IRED(DC)}$			125	mA
Power Dissipation		P_{tot}			450	mW
Junction Temperature		T_J			125	°C
Ambient Temperature Range (Operating)		T_{amb}	-25		85	°C
Storage Temperature Range		T_{stg}	-25		85	°C
Soldering Temperature	$t = 20\text{ s @}215\text{ }^\circ\text{C}$			215	240	°C
Transmitter Data and Shutdown Input Voltage	$2.4\text{ V} < V_{dd1} < 5.5\text{ V}$	V_{Txd}, V_{SD}	-0.5		6	V
Receiver Data Output Voltage		V_{Rxd}	-0.5		$V_{dd1}+0.5$	V
Virtual source size	Method: (1-1/e) encircled energy	d	2.5	2.8		mm
Max. Intensity for Class 1 operation of IEC 825 or EN60825	EN60825, 1.1.1997 Worst case IrDA pulse pattern, lab. conditions.				320*)	mW/sr

- *) Due to the IRDA[®] protocol, SIR and MIR mode data transfers have an equal distribution of "0" and "1" data, therefore the limit is typically a factor of 2 larger than the value for lab testing. The device is protected against Txd short (single fault condition) by an internal shut-off when the pulse duration is exceeding maximum IrDA specification value of pulse duration.

Optoelectronic Characteristics

$T_{amb} = 25^{\circ}\text{C}$, $V_{dd1} = 2.4\text{ V to }5.5\text{ V}$ unless otherwise noted.

Typical values are for DESIGN AID ONLY, not guaranteed nor subject to production testing.

Parameters	Test Conditions	Symbol	Min.	Typ.	Max.	Unit
Transceiver						
Supported Data Rates Rxd pulse duration 400 ns	Base band SIR mode		9.6		115.2	kbit/s
	Base band 1.152 Mbit/s		9.6		1152	kbit/s
Supply Voltage Range	specified operation	V_{dd1}	2.4		5.5	V
Supply Current receive mode	$V_{dd1} = 2.4\text{ V to }5.5\text{ V}$	I_S		200	250	μA
Supply Current shutdown mode	$V_{dd1} = 2.4\text{ V to }5.5\text{ V}$	I_{SSD}		0.1	1	μA
Average Supply Current *) Low power MIR transmit mode $I_e > 9\text{ mW/ sr}$	$V_{dd1} = 2.4\text{ V to }5.5\text{ V}$	I_S		5		mA
Average Supply Current *) Standard MIR transmit mode $I_e > 100\text{ mW/ sr}$	$V_{dd1} = 2.4\text{ V to }5.5\text{ V}$	I_S		60		mA
Shutdown / Mode clock pulse duration		t_{prog}	0.2		20	μs
Shutdown delay "Receive off"		t_{prog}	1		1.5	ms
Shutdown Delay "Receive on"		t_{prog}	40		100	μs
Transceiver "Power On" Settling Time	Time from switching on V_{dd1} to established specified operation				50	μs

*) Maximum data are for 20% (25%) duty cycle for SIR (MIR 1.152 Mbit/s) Low power mode. The typical value is given for the case of normal operation with statistical and equal "0" and "1" – distribution.

The transmitter current is programmable and can be switched by setting the mode input.

Mode switching affects only pulse current. Mode switch (pin 7) set to High: Output driver acts as a switch, the current is controlled by an external resistor. Mode switch Low: Internal current control is activated and controls the output intensity to be compliant with the low power Telecom standard.



Optoelectronic Characteristics

$T_{amb} = 25^{\circ}\text{C}$, $V_{dd1} = 2.4\text{ V to }5.5\text{ V}$ unless otherwise noted.

Typical values are for DESIGN AID ONLY, not guaranteed nor subject to production testing.

Parameters	Test Conditions	Symbol	Min.	Typ.	Max.	Unit
Receiver						
Minimum Detection Threshold Irradiance SIR (9.6 kbit/s to 115.2 kbit/s *)	$ \alpha \leq \pm 15^{\circ}$ $V_{dd1} = 2.4\text{ V to }5.5\text{ V}$	$E_{e, \min}$		20	35	mW/m^2
Minimum Detection Threshold Irradiance (9.6 kbit/s to 1.152 Mbit/s *)	$ \alpha \leq \pm 15^{\circ}$ $V_{dd1} = 2.4\text{ V to }5.5\text{ V}$	$E_{e, \min}$		50	80	mW/m^2
Maximum Detection Threshold Irradiance	$ \alpha \leq \pm 90^{\circ}$ $V_{dd1} = 5\text{ V}$	$E_{e, \max}$	3300	5000		W/m^2
	$ \alpha \leq \pm 90^{\circ}$ $V_{dd1} = 3\text{ V}$	$E_{e, \max}$	8000	15000		W/m^2
Logic Low Receiver Input Irradiance		$E_{e, \max, \text{low}}$	4			mW/m^2
Output Voltage Rxd	Active $C = 15\text{ pF}$, $R = 2.2\text{ k}\Omega$	V_{OL}		0.5	0.8	V
	Non active $C = 15\text{ pF}$, $R = 2.2\text{ k}\Omega$	V_{OH}	$V_{dd1} - 0.5$			V
Output Current Rxd $V_{OL} < 0.8\text{ V}$					4	mA
Rise Time @Load: $C = 15\text{ pF}$, $R = 2.2\text{ k}\Omega$		t_r	20		100	ns
Fall Time @Load: $C = 15\text{ pF}$, $R = 2.2\text{ k}\Omega$		t_f	20		100	ns
Rxd Signal Electrical Output Pulse Width	MIR mode	t_p	300	400	500	ns
Latency	MIR mode	t_L		100	200	μs

*) Rxd output pulse duration 400 ns

Optoelectronic Characteristics

$T_{amb} = 25\text{ }^{\circ}\text{C}$, $V_{dd1} = 2.4\text{ V to } 5.5\text{ V}$ unless otherwise noted.

Typical values are for DESIGN AID ONLY, not guaranteed nor subject to production testing.

Parameters	Test Conditions	Symbol	Min.	Typ.	Max.	Unit
Transmitter						
Logic CMOS High/Low Decision Threshold		$V_{IL}(Txd)$		$1/2 \times V_{dd1}$		V
Logic Low Transmitter Input Voltage		$V_{IL}(Txd)$	0		0.6	V
Logic High Transmitter Input Voltage	$2.4\text{ V} < V_{dd1} < 5.5\text{ V}$	$V_{IH}(Txd)$	$V_{dd1} - 0.5$		5.5	V
Programmable Current Levels		I_{F1}	40	50	70	mA
		I_{F6}	400	500*)	600	mA
Output Radiant Intensity, $ \alpha \leq \pm 15^{\circ}$ Low Power MIR level	$I_{F3} = 40\text{ mA}$ current controlled	I_e	11	18	40	mW/ sr
Output Radiant Intensity, $ \alpha \leq \pm 15^{\circ}$ Standard MIR level	$I_{F6} = 400\text{ mA}$ resistor limited	I_e	110	250	320	mW/ sr
Maximum Output Pulse width (eye safety protection)	$P_{WI} > 23\text{ }\mu\text{s}$	P_{WOmin}	23		80	μs
Optical Pulse width	$P_{WI} > 1.6\text{ }\mu\text{s}$	P_{WO}	1.45		1.75	μs
	$P_{WI} > 217\text{ ns}$	P_{WO}	210		226	ns
Optical Rise/Falltime		t_r, t_f			40	ns
Peak Wavelength of Emission		λ_p	880		900	nm
Spectral Optical Radiation Bandwidth		$\Delta\lambda$		60		nm
Output Radiant Intensity	Txd logic low level				0.04	$\mu\text{W/sr}$
Overshoot, Optical					25	%
Rising Edge Peak to Peak Jitter		t_j			0.2	μs

*) Switch, current can be defined by external resistor, internal current limitation to typically 500 mA peak

Recommended SMD Pad Layout

The leads of the device should be soldered in the center position of the pads.

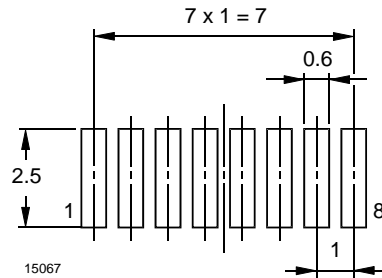
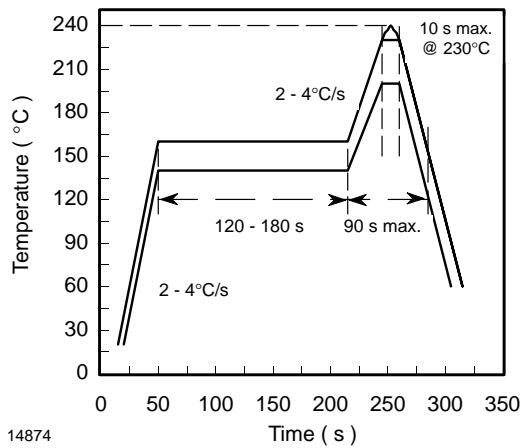

Figure 3. TFDU5106 Baby Face (Universal)

Recommended Solder Profile



14874

Figure 4. Recommended Solder Profile

Current Derating Diagram

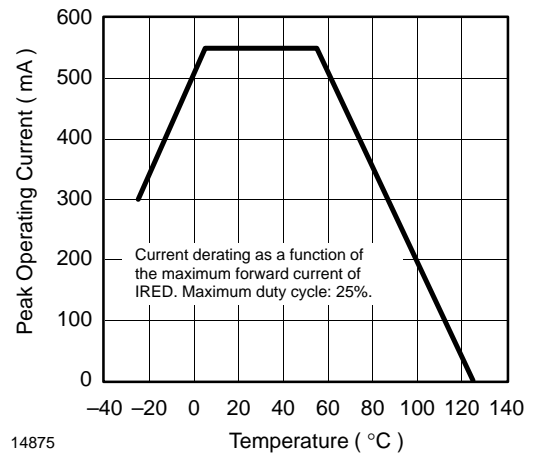

14875

Figure 5. Current Derating Diagram

Identification

The identification of the device can be recalled by setting the SD active followed by activating Txd for a short period. With the low going edge of Txd a single pulse is generated at Rxd.

The SD is indendet to activate the shutdown function after a delay of 1 ms. Therefore the full sequence should be run with that 1 ms time limitation, see drawing.

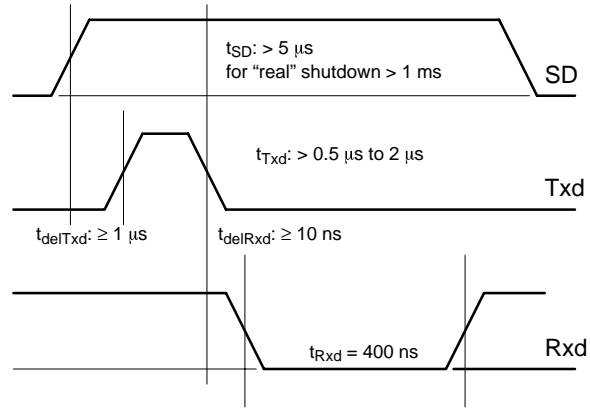

Figure 6.

The transmitter current is programmable and can be switched by setting the mode input (Pin 7) Mode switching affects only pulse current. Mode switch (Pin 7) set to "High": Output driver acts as switch, the current is controlled by an external resistor

but limited by an internal overload protection. Mode switch set to "Low": Internal current control is activated and controls the output intensity to be compliant with the low power Telecom standart.

Table 1. Truth table

Inputs				Outputs	
SD	Txd	Mode pad	Optical input Irradiance mW/m^2	Rxd	LED drive current resulting intensity I_e in mW/sr
high < 1 ms	pulse	x	x	low going Txd triggers monostable to edit a 400 ns low pulse	0
high > 1 ms	x	x	x	floating ($500 k\Omega$ to V_{dd})	0
low	high	low	x	high	> 10
low	high > $80 \mu s$	low	x	high	0
low	high	high	x	high	$10 < I_e < 300$ defined by an external resistor
low	high > $80 \mu s$	high	x	high	0
low	low	x	< 4	high	0
low	low	x	> 40	low, pulse of 400 ns edge triggered	0

TFDU5106 – Baby Face (Universal) Package (Mechanical Dimensions)

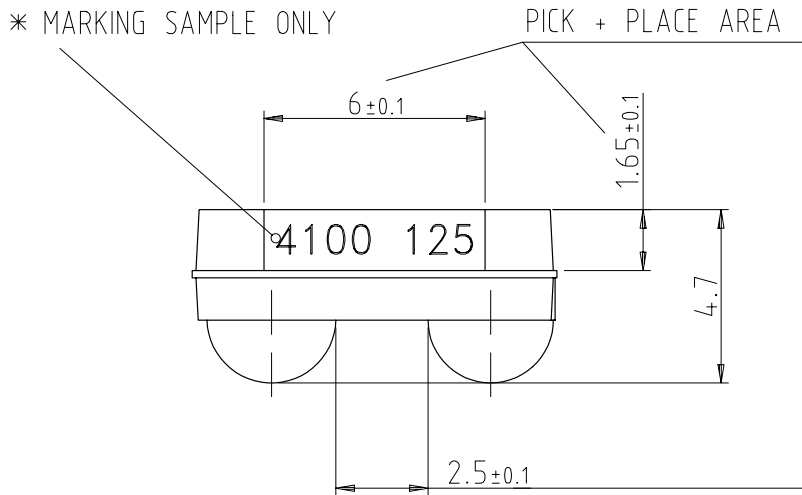
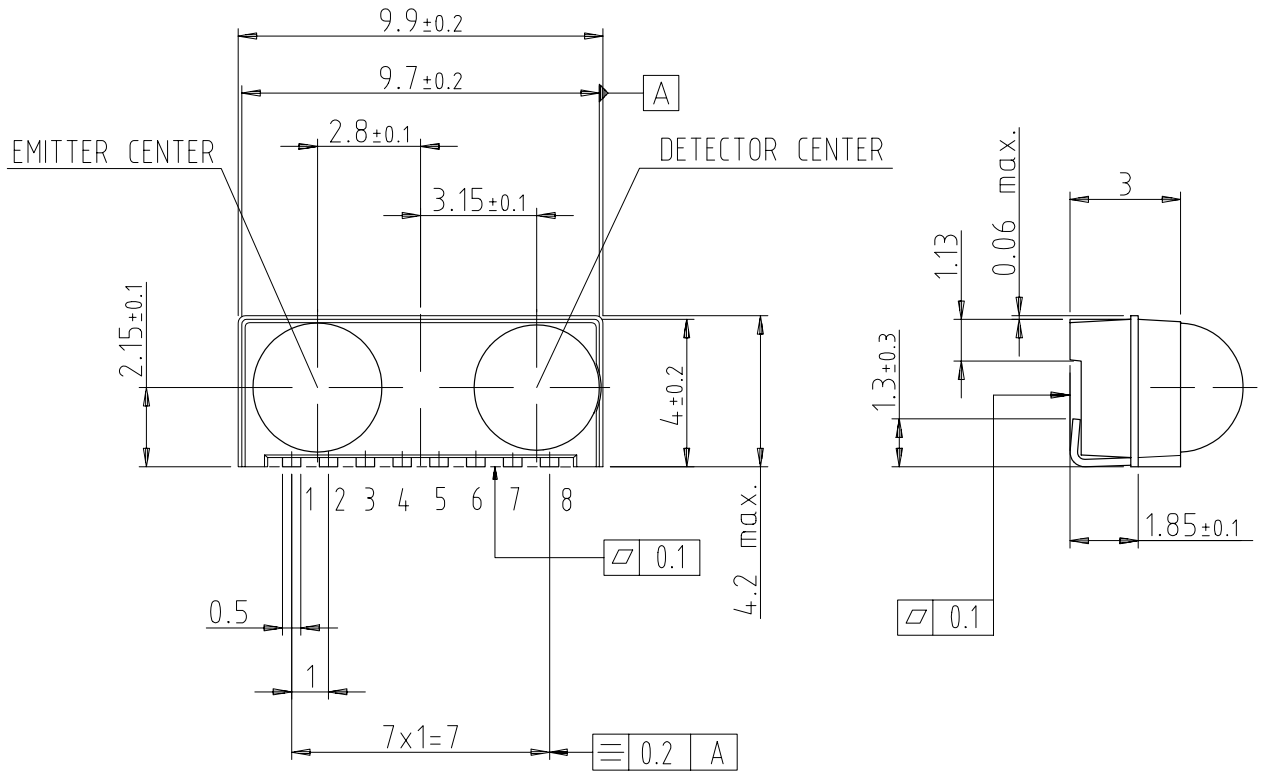

* MARKING ORIENTATION
180 DEGREES ALLOWED

Drawing-No.: 6.550-5148.01-4
Issue: 8; 10.7.98

12249

 technical drawings
 according to DIN
 specifications

Appendix

Application Hints

The TFDU5106 do not need any external components when operated at a "clean" power supply. In a more noisy ambient it is recommended to add a combination of a resistor and capacitor (R1, C1, C2) for noise suppression as shown in the figure below. A combination of an electrolytic for the low frequency range and a ceramic capacitor for suppressing the high frequency disturbance will be most effective.

The inputs TXD and SD are high impedance CMOS inputs. Therefore, the lines from the I/O to those inputs should be carefully designed not to pick up ambient noise. If long lines are used, loads at the Txd input of the TFDx5x06 and at the Rxd input of the controller (!) are recommended. At the IRED Anode voltage supply line an additional capacitor might be necessary when inductive wiring is used. However, a low impedance layout is the better and more cost efficient solution. For adjusting the intensity depending on the application, see the diagrams.

Recommended Circuit Diagram

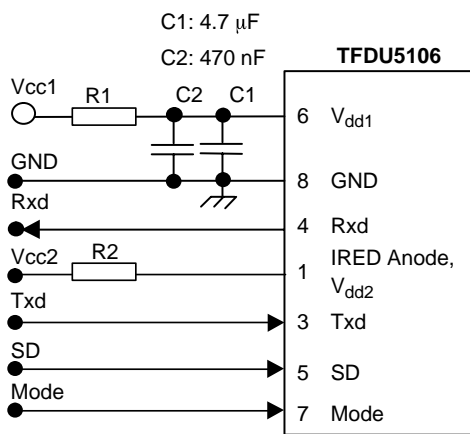

Figure 7. Recommended Application Circuit

Shut Down

To shut down the TFDx5x06 into a standby mode the SD pin has to be set active. After a delay of < 1 ms it will switch to the standby mode.

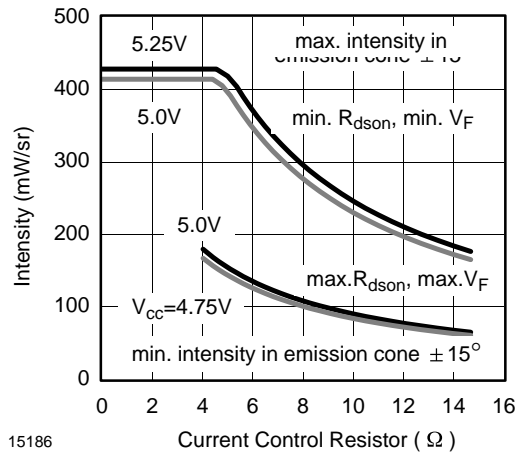

Figure 8. Intensity I_e vs. Current Control Resistor R2
5 V Applications

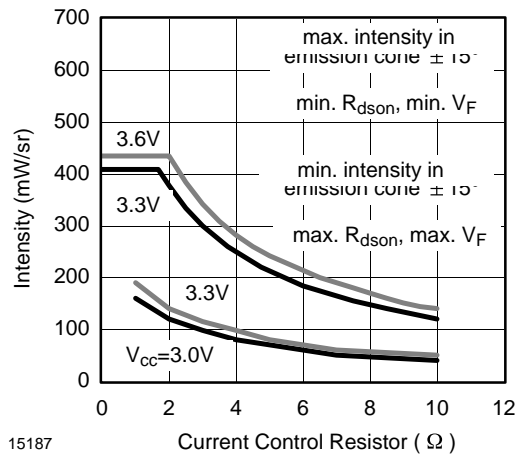

Figure 9. Intensity I_e vs. Current Control Resistor R2,
3 V Applications

Latency

The receiver is in specified conditions after the defined latency. In a UART related application after that time (typically 50 μ s) the receiver buffer of the UART must be cleared. Therefore, the transceiver has to wait at least the specified latency after receiving the last bit before starting the transmission to be sure that the corresponding receiver is in a defined state.



Table 1. Recommended Application Circuit Components

Component	Recommended Value	Vishay Part Number
C1	4.7 μ F, 16 V	293D 475X9 016B 2T
C2	0.1 μ F, Ceramic	VJ 1206 Y 104 J XXMT
R1	47 Ω , 0.125 W	CRCW-1206-47R0-F-RT1
R2	5 V supply voltage: 14 Ω , 0.25 W (recommend using two 6.8 Ω , 0.125 W resistors in series) 3.0 V supply voltage: 4.5 Ω , 0.25 W (recommend using two 2.3 Ω , 0.125 W resistors in series)	CRCW-1206-6R80-F-RT2 CRCW-1206-2R26-F-RT1



Revision History:

A1.0a, 01/12/1999: Confidential marking taken off, after clean-up through Marketing and Marcom free to public access



Ozone Depleting Substances Policy Statement

It is the policy of **Vishay Semiconductor GmbH** to

1. Meet all present and future national and international statutory requirements.
2. Regularly and continuously improve the performance of our products, processes, distribution and operating systems with respect to their impact on the health and safety of our employees and the public, as well as their impact on the environment.

It is particular concern to control or eliminate releases of those substances into the atmosphere which are known as ozone depleting substances (ODSs).

The Montreal Protocol (1987) and its London Amendments (1990) intend to severely restrict the use of ODSs and forbid their use within the next ten years. Various national and international initiatives are pressing for an earlier ban on these substances.

Vishay Semiconductor GmbH has been able to use its policy of continuous improvements to eliminate the use of ODSs listed in the following documents.

1. Annex A, B and list of transitional substances of the Montreal Protocol and the London Amendments respectively
2. Class I and II ozone depleting substances in the Clean Air Act Amendments of 1990 by the Environmental Protection Agency (EPA) in the USA
3. Council Decision 88/540/EEC and 91/690/EEC Annex A, B and C (transitional substances) respectively.

Vishay Semiconductor GmbH can certify that our semiconductors are not manufactured with ozone depleting substances and do not contain such substances.

We reserve the right to make changes to improve technical design and may do so without further notice.

Parameters can vary in different applications. All operating parameters must be validated for each customer application by the customer. Should the buyer use Vishay Telefunken products for any unintended or unauthorized application, the buyer shall indemnify Vishay Telefunken against all claims, costs, damages, and expenses, arising out of, directly or indirectly, any claim of personal damage, injury or death associated with such unintended or unauthorized use.

Vishay Semiconductor GmbH, P.O.B. 3535, D-74025 Heilbronn, Germany
Telephone: 49 (0) 7131 67 2831, Fax number: 49 (0) 7131 67 2423



Disclaimer

All product specifications and data are subject to change without notice.

Vishay Intertechnology, Inc., its affiliates, agents, and employees, and all persons acting on its or their behalf (collectively, "Vishay"), disclaim any and all liability for any errors, inaccuracies or incompleteness contained herein or in any other disclosure relating to any product.

Vishay disclaims any and all liability arising out of the use or application of any product described herein or of any information provided herein to the maximum extent permitted by law. The product specifications do not expand or otherwise modify Vishay's terms and conditions of purchase, including but not limited to the warranty expressed therein, which apply to these products.

No license, express or implied, by estoppel or otherwise, to any intellectual property rights is granted by this document or by any conduct of Vishay.

The products shown herein are not designed for use in medical, life-saving, or life-sustaining applications unless otherwise expressly indicated. Customers using or selling Vishay products not expressly indicated for use in such applications do so entirely at their own risk and agree to fully indemnify Vishay for any damages arising or resulting from such use or sale. Please contact authorized Vishay personnel to obtain written terms and conditions regarding products designed for such applications.

Product names and markings noted herein may be trademarks of their respective owners.